

READ BEFORE USE

使用前阅读

Visit www.hamiltonbeach.cn for our complete line of products and Use and Care Guides – as well as delicious recipes, tips, and to register your product online!

有关我们所有系列产品的使用与维护指南 – 以及美味食谱、生活小贴士和产品在线注册的更多信息，请访问 www.hamiltonbeach.cn。

Questions?

Please call us – our friendly associates are ready to help.
China: 400-852-2655

如有疑问？

请致电我们，我们的团队随时准备为您提供帮助。

中国大陆客服热线：

400-852-2655

官方网站：www.hamiltonbeach.cn

型号：49980-CN

此说明书中图片仅供参考，产品以实物为准。

使用本设备前，我们建议您仔细阅读这些说明。

Hamilton 汉美驰 Beach®

The Scoop™ 2-Way
Brewer

Scoop™ 智能双模
咖啡机



English 2

简体中文 16

IMPORTANT SAFEGUARDS

When using electrical appliances, basic safety precautions should always be followed to reduce the risk of fire, electric shock, and/or injury to persons, including the following:

1. Read all instructions.
2. Do not touch hot surfaces. Use handles or knobs. Care must be taken, as burns can occur from touching hot parts or from spilled, hot liquid.
3. To protect against electric shock, do not place cord, plug, or coffeemaker in water or other liquid.
4. Close supervision is necessary when any appliance is used by or near children.
5. Allow to cool before putting on or taking off parts and before cleaning the appliance.
6. Coffeemaker must be operated on a flat surface away from the edge of counter to prevent accidental tipping.
7. Do not operate any appliance with a damaged cord or plug, or after the appliance malfunctions or has been damaged in any manner. Call our toll-free customer service number for information on examination, repair, or adjustment.
8. The use of accessory attachments not recommended by the appliance manufacturer may cause injuries.
9. Do not use outdoors.
10. Do not let cord hang over edge of table or counter or touch hot surfaces, including stove.
11. Do not place on or near a hot gas or electric burner, or in a heated oven.
12. The carafe is designed for use with this coffeemaker. It must never be used on a range top or in a microwave oven.
13. Do not set a hot carafe on a wet or cold surface.
14. Do not use a cracked carafe or one with a loose or weakened handle.
15. Do not clean carafe with cleansers, steel wool pads, or other abrasive materials.
16. Do not use appliance for other than intended use.
17. **WARNING:** To reduce the risk of fire or electric shock, do not remove the bottom cover of the coffeemaker. There are no user-serviceable parts inside. Repair should be done by authorized service personnel only.
18. To disconnect, turn any control to the OFF position and then remove plug from wall outlet.
19. Be certain carafe lid is securely in place during brew cycle and when pouring coffee. Do not use force when placing lid on carafe.

SAVE THESE INSTRUCTIONS!

OTHER CONSUMER SAFETY INFORMATION

This appliance is intended for household use only.

The length of the cord used on this appliance was selected to reduce the hazards of becoming tangled in or tripping over a longer cord. If a longer cord is necessary, an approved extension cord may be used. The electrical rating of the extension cord must be equal to or greater than the

rating of the appliance. Care must be taken to arrange the extension cord so that it will not drape over the countertop or tabletop where it can be pulled on by children or accidentally tripped over.

To avoid an electrical circuit overload, do not use another high-wattage appliance on the same circuit with this appliance.

Single-Serve Side Parts and Features

Carafe Side Parts and Features

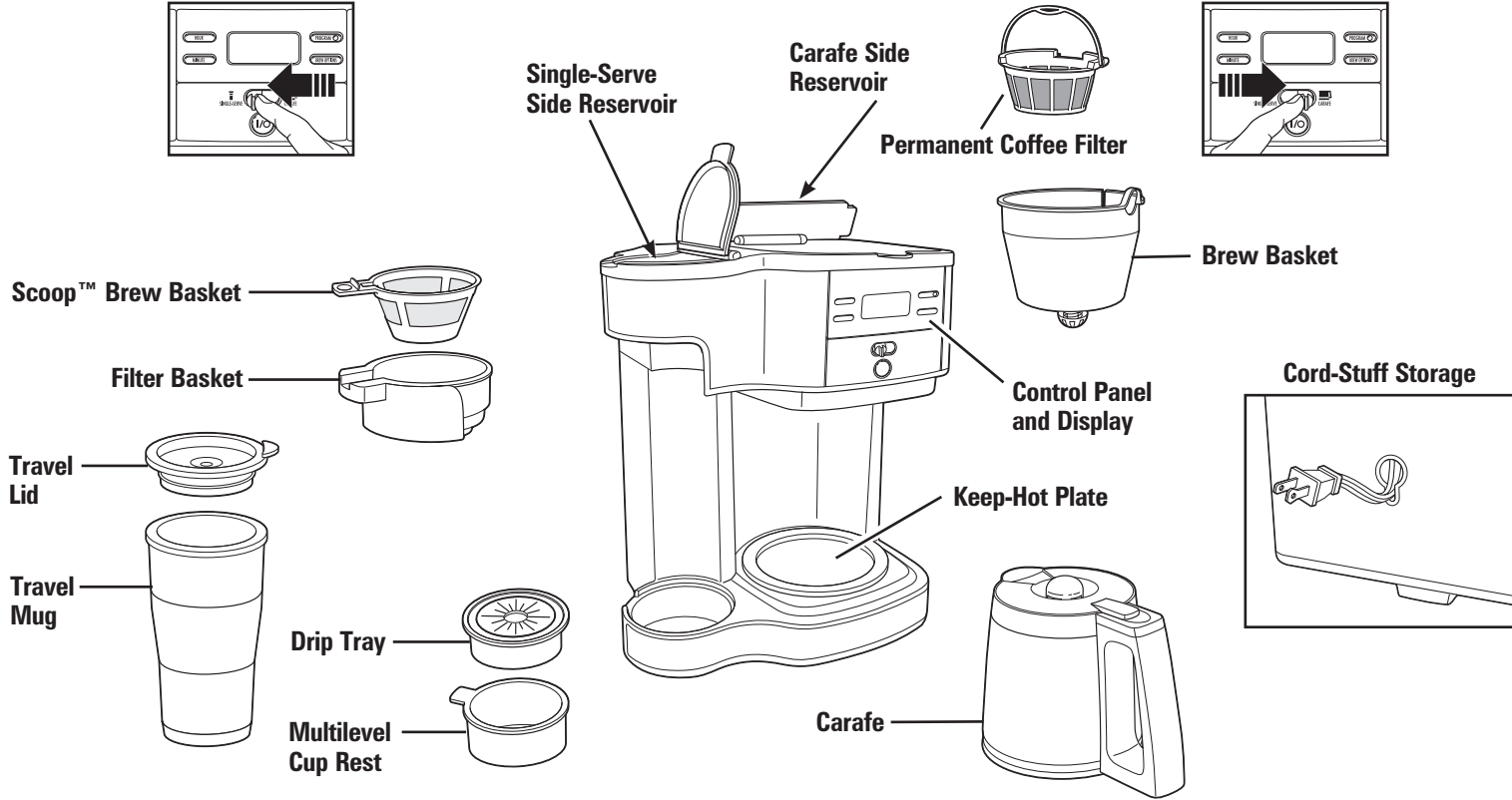

How to Use Single-Serve Side

⚠ WARNING Burn Hazard.

To avoid contact with hot coffee or water:

- Do not use more than 14 ounces (410 ml) of water.
- Fill single-serve reservoir with mug or cup into which the coffee will be brewed.

- Fully insert mug or cup under filter basket.

AUTOMATIC SHUTOFF: The coffeemaker will automatically shut off after brew cycle is complete.

NOTES:

- The unit will only brew on one side at a time.
- To avoid overflow, use slightly less grounds when brewing decaf or flavored coffees.
- For Hotter Coffee: Rinse the travel mug with warm water before brewing; then replace travel mug lid. Brew directly into the travel mug with travel mug lid in place.

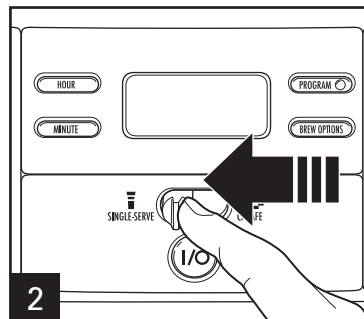
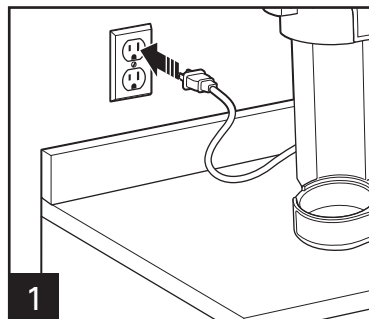

Push lever left to select Single-Serve.

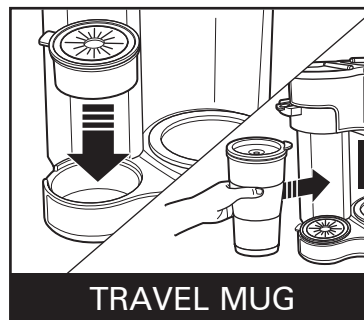
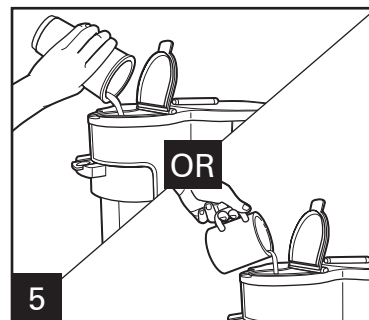
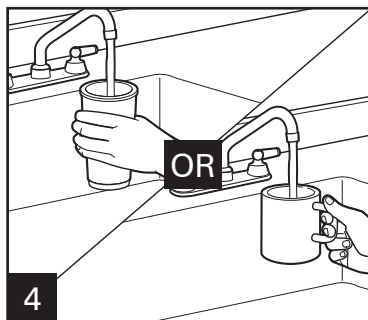
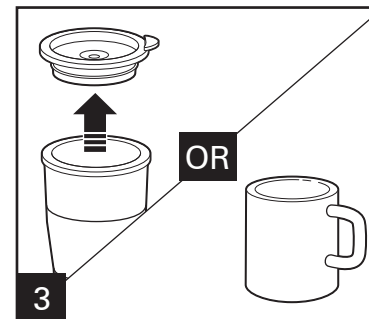

How to Use Single-Serve Side (cont.)

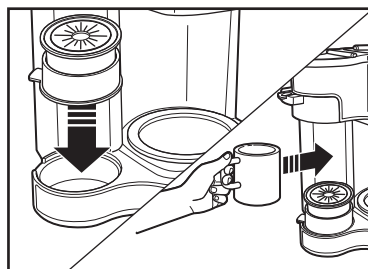

REGULAR MUG

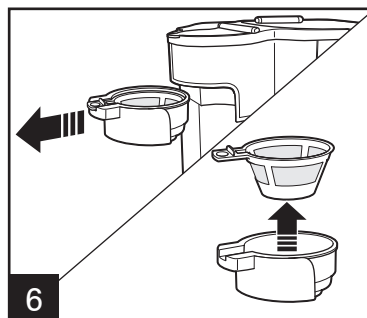

6

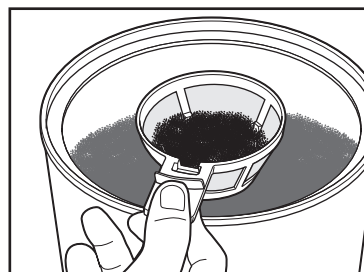

7A-1 – GROUND

For regular coffee, use a maximum of two level table-spoons of grounds. To avoid overflow, use slightly less grounds when brewing decaf or flavored coffees.

WARNING! Keep ground coffee below MAX fill line to prevent overflow.

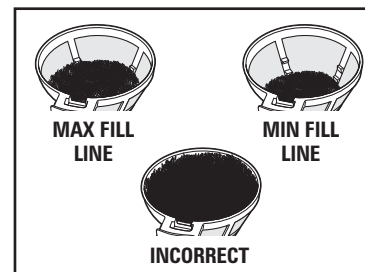

MAX FILL
LINE

MIN FILL
LINE

INCORRECT

7A-2 – GROUND

Single-serve brew basket has two markings: the lower level marking if making 8 oz. (250 ml) of coffee, and the higher level mark if making 14 oz. (410 ml) of coffee. **DO NOT** fill scoop to top or this will cause overflow.

How to Use Single-Serve Side (cont.)

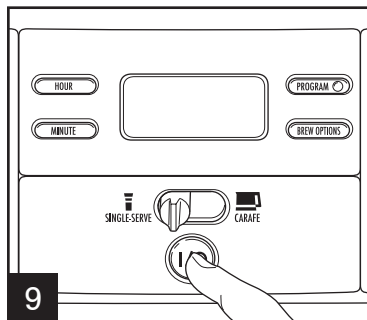
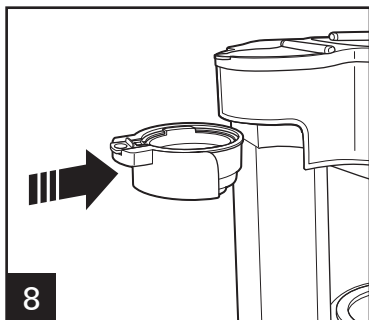

Press **I/O (ON/OFF)** button to begin the flow of coffee. Coffeemaker will shut off when brew cycle is complete. To stop flow of coffee midcycle, press **I/O (ON/OFF)** button.

How to Use Carafe Side

AUTOMATIC SHUTOFF: The coffeemaker will automatically shut off 2 hours after brew cycle is complete.

NOTE: The unit will only brew on one side at a time.

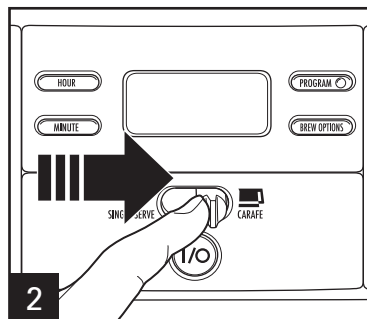
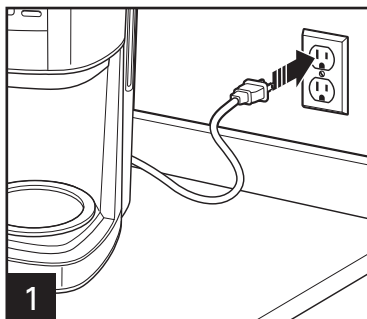

Push lever right to select Carafe.

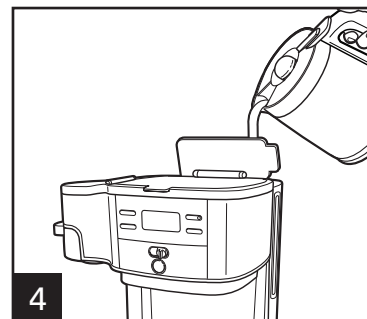
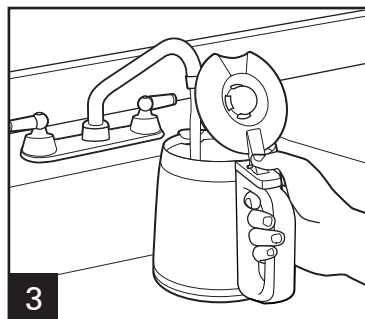

Lift lid and pour water from carafe into reservoir.
NOTE: Do not fill past the 12-cup mark (60 ounces [1.8 L]).

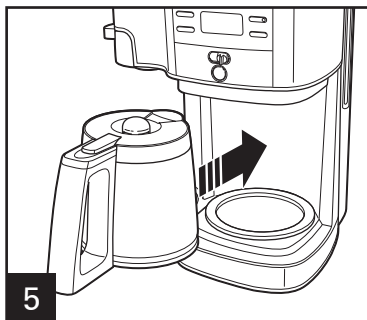

Place carafe, with carafe lid attached, on keep-hot plate.

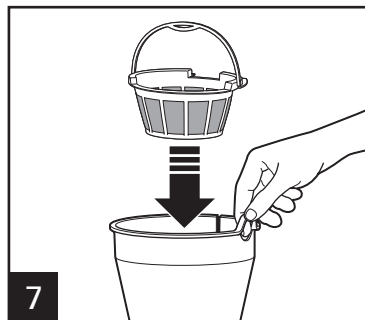
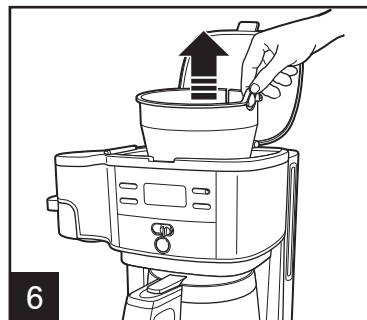

Place a permanent filter in brew basket. A cupcake-style paper filter may also be used.

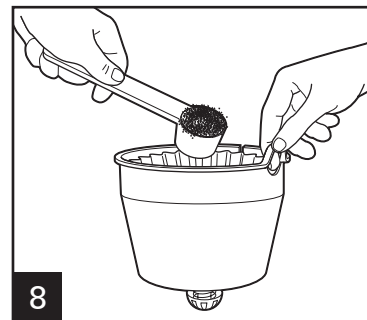

For each cup of coffee being made, place one level tablespoon (15 ml) of coffee into filter.

How to Use Carafe Side (cont.)

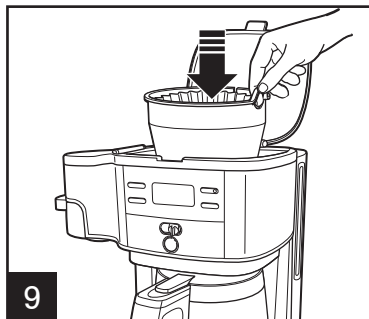

9

Place brew basket in brew basket well. Ensure brew basket is fully seated.

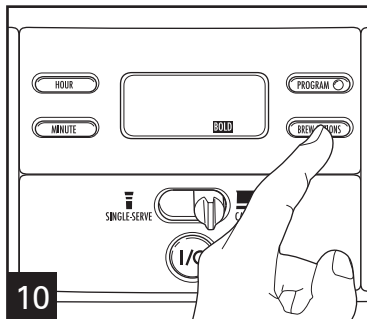

10

For enhanced full/strong-flavored coffee, press **BREW OPTIONS** button until **BOLD** is displayed.

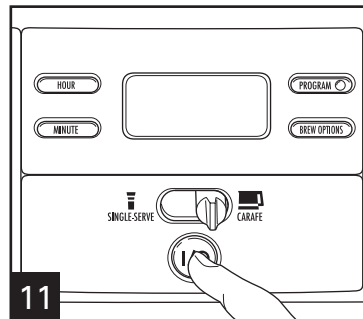

11

Press **I/O (ON/OFF)** button to start. Press **I/O (ON/OFF)** button again to turn off.

NOTE: If the coffeemaker is not turned off manually, it will automatically shut off in 2 hours.

NOTE: BOLD mode will require additional time to complete a brewing cycle. If Brew Option is not selected, the coffeemaker will automatically brew on the regular/default setting.

Programming (For Either the Single-Serve OR Carafe Side)

NOTE: The unit will only brew on one side at a time.

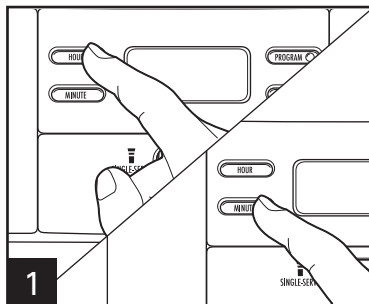

Press **HOUR** and then **MINUTE** to set clock.

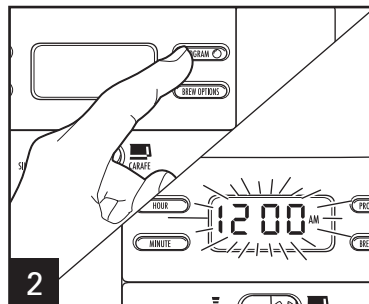

Hold **PROGRAM** until clock flashes.

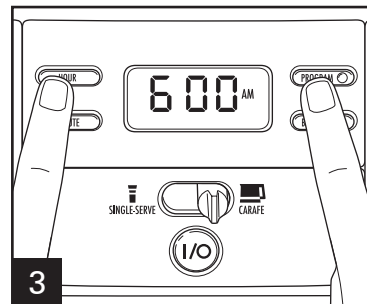

Continue holding **PROGRAM** button, press **HOUR** and **MINUTE** until the desired brewing start time is reached, and then release **PROGRAM** button.

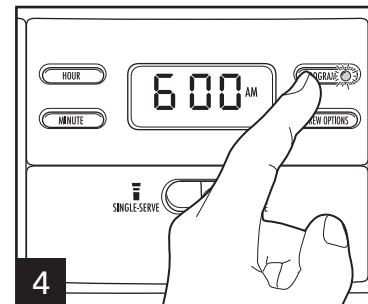

Press **PROGRAM** to activate automatic brewing. A green LED will illuminate to indicate the unit is programmed.

Tips for Best-Tasting Coffee

- All coffees are made from either arabica beans or robusta beans, or some combination of both. Arabica beans are slightly more expensive, but tend to produce better-tasting coffee.
- Ground coffee will become stale much faster than whole beans. If buying preground coffee, choose a package with the latest expiration date or a smaller quantity.
- If grinding whole beans, set your coffee grinder on a fine/medium grind. This will yield the best-tasting grounds. Try to use freshly ground coffee within about a week of grinding.
- Using a water filter, filtered water, or bottled water will yield better-tasting coffee than tap water.
- Use approximately 1 tablespoon of grounds for each cup of coffee being made. To avoid overflow, use slightly less grounds (3/4 table-spoon [11 ml]) when brewing decaf or flavored coffees. Also, be aware that using coffee that is ground too finely may also cause the filter basket to overflow.
- Make sure your coffeemaker is clean. See “Care and Cleaning” sections.

Care and Cleaning – Single-Serve Side

All coffeemakers should be cleaned at least once a month (once a week for areas with hard water).

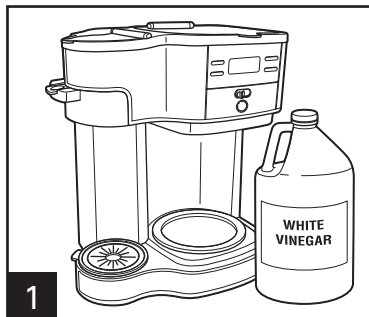

Pour 1/2 cup (125 ml) of plain white vinegar and 1/2 cup (125 ml) of cold water into single-serve side reservoir.

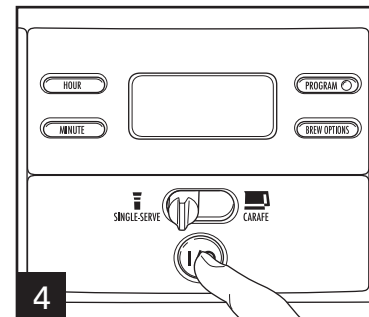
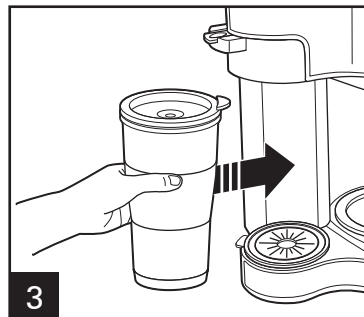
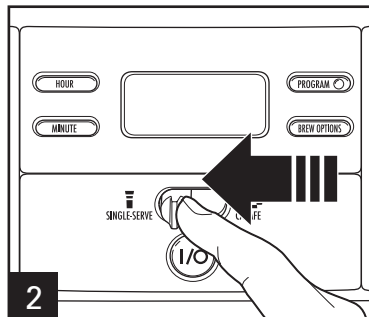

Press **I** (ON) button. Press **O** (OFF) button after 30 seconds and wait 30 minutes. Press **I** (ON) button. Press **O** (OFF) button when finished.

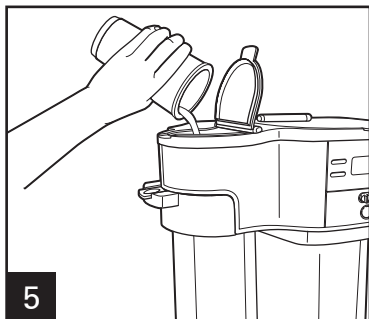

Run 2–3 more brew cycles with **CLEAN WATER** only. Allow to cool between cycles.

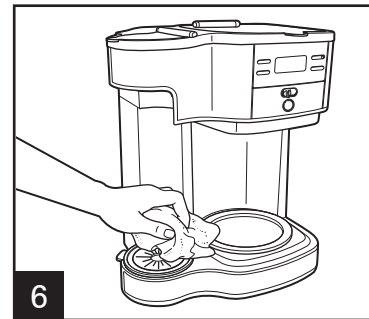

Care and Cleaning – Carafe Side

All coffeemakers should be cleaned at least once a month (once a week for areas with hard water).



Pour 1 pint (2 cups/500 ml) vinegar into carafe side reservoir.

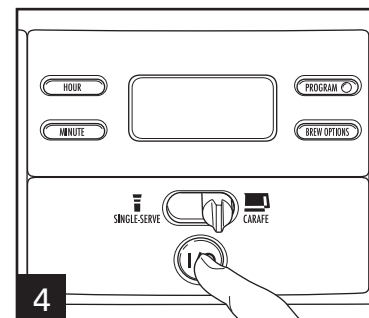
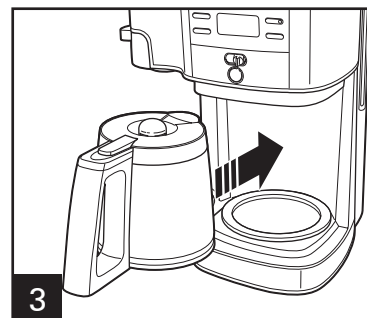
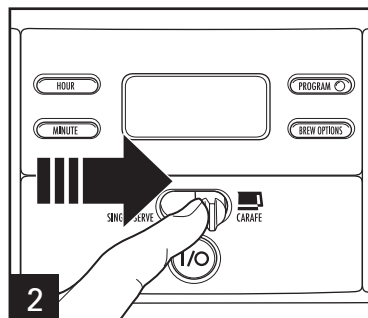

Press **I** (ON) button. Press **O** (OFF) button after 30 seconds and wait 30 minutes. Press **I** (ON) button. Press **O** (OFF) button when finished.

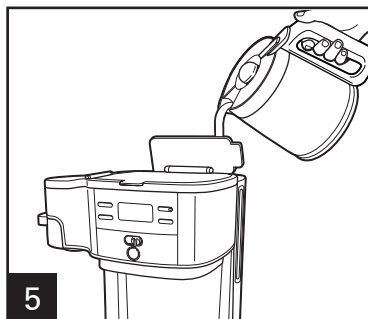

Run 2-3 more brew cycles with **CLEAN WATER** only. Allow to cool between cycles.

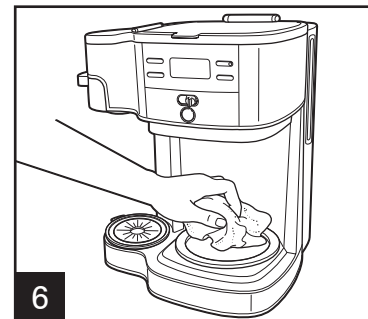

Troubleshooting (Single-Serve Side)

PROBLEM

PROBABLE CAUSE

Weak coffee.

- Not enough ground coffee used. See “How to Use Single-Serve Side.”

Coffee overflows from brew basket, travel mug, or regular mug.

- Excessive amount of water in single-serve reservoir. Use travel mug or mug into which coffee will be brewed to fill reservoir. Use slightly less grounds when brewing decaffeinated or flavored coffees. Set coffee grinder to automatic drip grind.

Coffee tastes bad.

- Coffeemaker needs cleaning.
- Coffee ground too coarsely or too finely. Set coffee grinder to automatic drip grind.
- Poor coffee quality and freshness.
- Poor water quality (use filtered or bottled water).

Troubleshooting (Carafe Side)

PROBLEM

PROBABLE CAUSE

Brew basket overflows or coffee brews slowly.

- Excessive amounts of ground coffee.
- Decaffeinated and/or coffee ground too finely can cause overflow. Set coffee grinder to automatic drip grind and use slightly less grounds.
- Coffeemaker needs cleaning.
If using a paper filter:
 - Coffee grounds between paper filter and brew basket.
 - Paper filter not open and in proper position.
 - Rinse brew basket before inserting paper filter so the edges will remain pressed against the sides of the basket.
 - Poor-quality paper filter.

Coffee leaks onto base.

- Carafe removed from keep-hot plate for more than 20 seconds during the brewing cycle.

Coffee tastes bad.

- Coffeemaker needs cleaning.
- Coffee ground too coarsely or too finely. Set coffee grinder to automatic drip grind.
- Coffee-to-water ratio unbalanced. Adjust for personal preference.
- Poor coffee quality and freshness.
- Poor water quality (use filtered or bottled water).

Troubleshooting (Carafe Side) (cont.)

PROBLEM

PROBABLE CAUSE

Coffee sediment in cup.

- Use a high-quality, basket-style paper filter instead of permanent coffee filter.

Coffee not brewing or unit will not turn on.

- Carafe not positioned on keep-hot plate.
- Water reservoir is empty.
- Unit is unplugged.
- Power outage.
- Power surge. Unplug; then plug the unit back in.
- Clock requires reset after power outage.

Longer than normal brew time.

- Mineral deposits can build up in the pump of your coffeemaker. Periodic cleaning of the inside of the unit is recommended. More frequent cleaning may be necessary, depending on the hardness of your water. See "Care and Cleaning – Carafe Side" section.
- NOTE:** Do not disassemble the unit.

重要安全说明

为避免发生火灾，触电以及人身伤害，在使用家用电器时，需遵守以下基本安全防护措施：

1. 阅读所有相关说明。
2. 请勿直接接触任何发热表面。请使用手柄或者旋钮。特别注意：在直接接触电器高温部件或溅到高温液体的情况下，可能造成皮肤烫伤。
3. 为防止触电，请勿将电源线、插头或咖啡机放入水或其他液体中。
4. 当电器由儿童使用或距离儿童较近时，需有成人看护。
5. 拆装咖啡机部件以及清洁前，必须让咖啡机冷却。
6. 咖啡机必须放在平整桌面进行操作，远离桌子边缘，以防其意外倾翻。
7. 当电源线或电插头受损，电器出现故障或因任何其他方式出现电器损坏时，请勿使用任何电器。请拨打我们的免费售后服务电话，咨询有关电器检查、修理或调整的相关信息。
8. 使用非电器制造商推荐的配套附件可能会带来伤害。
9. 请勿在户外使用。
10. 请勿将电源线搭置在桌台边缘上以及与发热表面接触，包括加热器。
11. 请勿靠近或放置在燃气或电炉上，或放进加热烤箱内。
12. 咖啡壶专为本咖啡机设计使用。使用时，切勿放在桌面边缘或置于微波炉中。
13. 请勿将热咖啡壶放置在潮湿或冰凉表面。
14. 请勿使用带裂缝、手柄松弛或脆弱的咖啡壶。
15. 请勿使用清洁剂、钢丝垫或其他磨砂型材料清洁咖啡壶。
16. 请勿将电器用作其他非预期用途。
17. **警告：**为防发生火灾或触电，请勿取下此咖啡机的底盖。此咖啡机内部无任何用户可维修的部件。仅允许授权的维修人员执行维修。
18. 断开咖啡机电源时，先将控制按钮调至 OFF 位置，再拔除插头。
19. 冲泡咖啡或倒咖啡时，请确保咖啡壶盖已扣紧。

请妥善保管这些说明！

其他用户安全信息

此电器建议于家庭使用。

此电器的电源线长度是经特别设计，以防电源线缠绕或绊倒他人。倘若需要更长的电源线，可使用批准的电源延长线。电源延长线的额定电功率必须等

于或大于此电器的额定电功率。电源延长线使用时需特别注意，以防将其搭设在桌台上，造成儿童扯拉或绊倒他人。

为防电路过载，请勿在此电器的同一电路上使用其他高功率电器。

单杯式 部件与功能

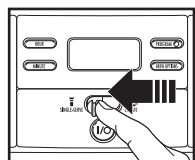

单杯式水箱

Scoop™ 过滤器



咖啡篮

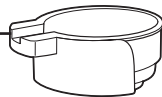

旅行
马克杯杯盖

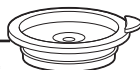

旅行
马克杯

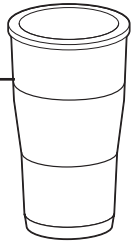

承滴盘



多层式杯座



咖啡壶式 部件与功能

咖啡壶
水箱



永久过滤器

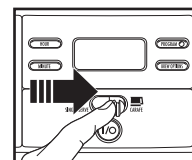

咖啡篮

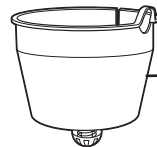

控制面板和
显示面板

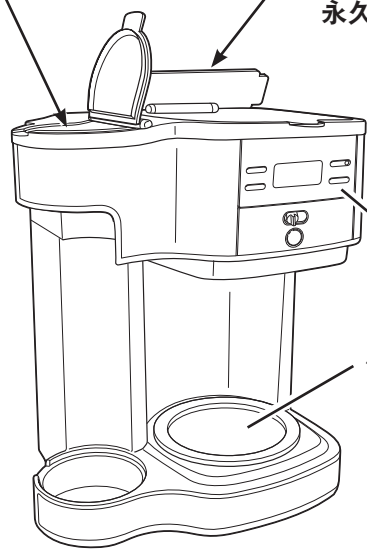

保温板

咖啡壶

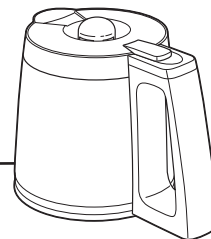

收线式存储

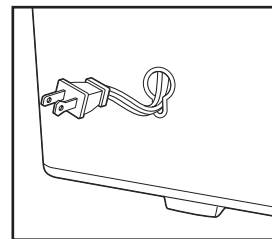

如何使用 单杯式

自动停止：冲泡周期完成后，咖啡机将自动关闭。

注意：

- 咖啡机一次只可进行一侧冲泡。
- 为避免溢出，冲泡脱因咖啡或调味咖啡时，请稍减咖啡粉用量。
- 冲泡更热的咖啡：冲泡前，请用温水冲洗旅行马克杯，然后再冲洗杯盖。盖紧杯盖后，直接将热咖啡冲入旅行马克杯中。

⚠ 警告 烫伤危险

为避免触到热咖啡或热水：

- 请勿使用超过 14 盎司（410 毫升）的水。
- 使用马克杯或咖啡杯向水箱中加入用来冲泡咖啡的水。

- 将马克杯或咖啡杯放在咖啡篮下面。

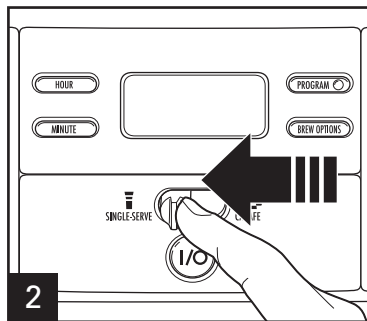
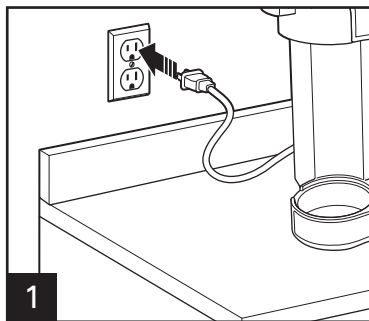

将滑块拨至左边，选择单杯式。

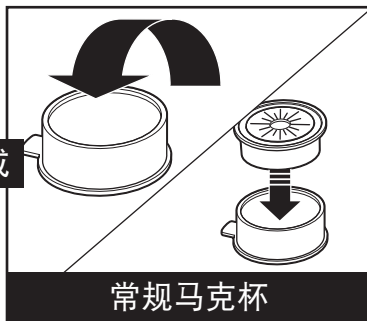
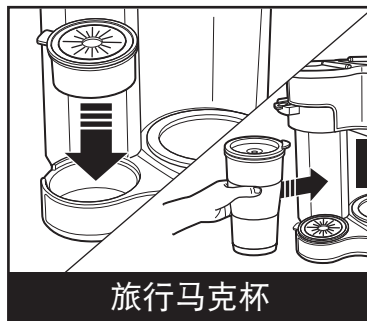
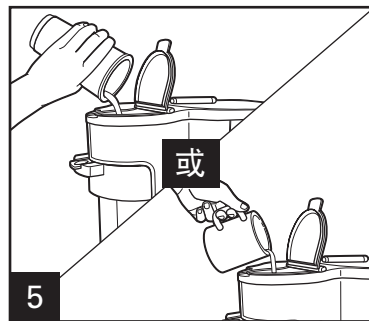
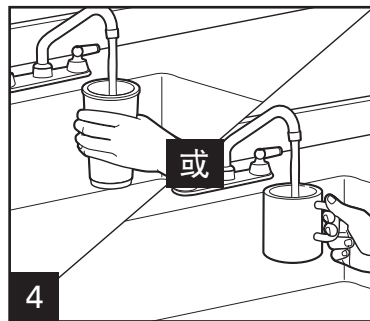
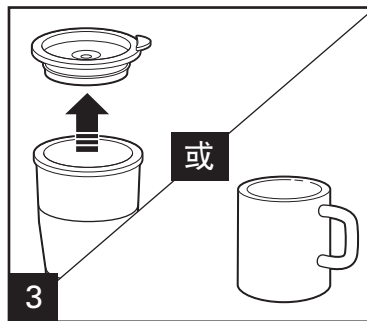

如何使用单杯式 (续)

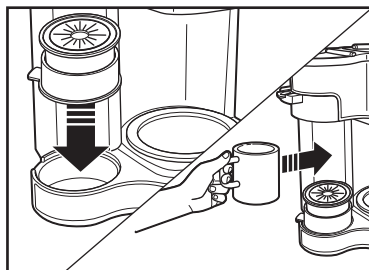

常规马克杯

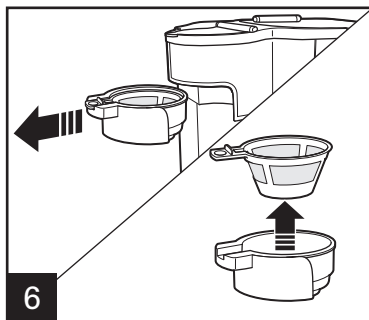

6

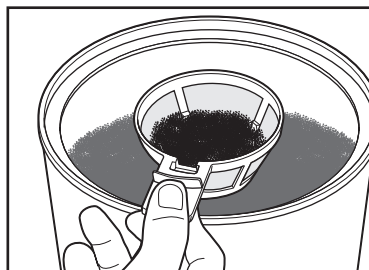

7A-1 – 咖啡粉

要冲泡普通咖啡，请最多使用两咖啡勺咖啡粉。为避免溢出，冲泡脱因或调味咖啡时，请稍减咖啡粉用量。

警告！请将咖啡粉用量保持在最大加注线以下，防止溢出。

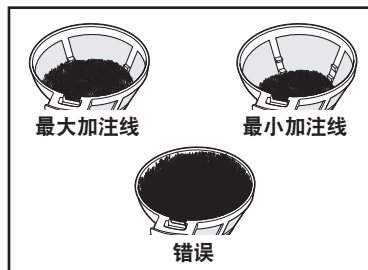

7A-2 – 咖啡粉

单杯式过滤器有两个标记：冲泡 8 盎司（250 毫升）咖啡的较低水位标记和冲泡 14 盎司（410 毫升）咖啡的较高水位标记。请勿将过滤器加至最高水位，否则将会导致溢出。

如何使用单杯式 (续)

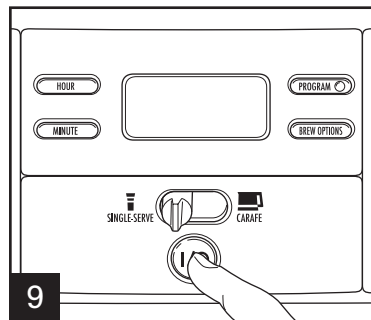
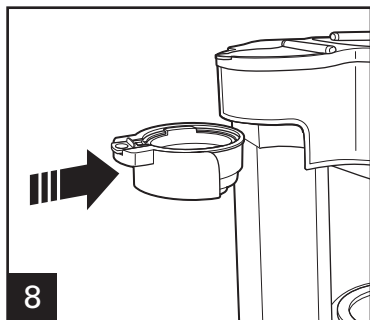

按 I/O (开/关) 按钮，开始冲泡咖啡。冲泡周期完成后，咖啡机将会关闭。要中途停止冲泡，则按 I/O (开/关) 按钮。

如何使用咖啡壶式

自动停止：冲泡周期完成 2 小时后，咖啡机将自动关闭。

注意：咖啡机一次只可进行一侧冲泡。

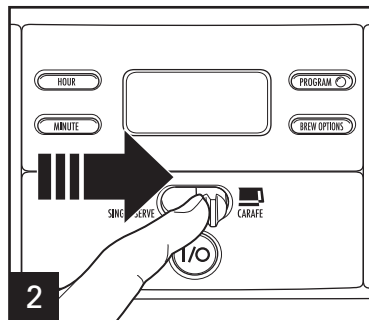
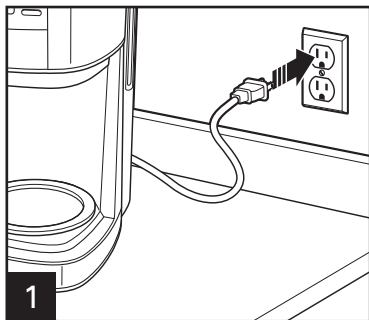

将滑块拨至右边，选择咖啡壶。

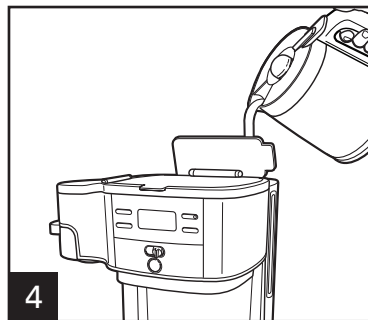
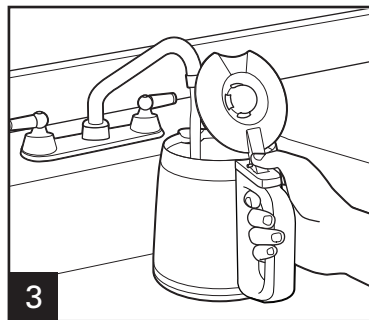

拉起瓶盖，将水从咖啡壶倒入水箱。
注意：加水请勿超过 12 杯标记
(60 盎司 [1.8 升])。

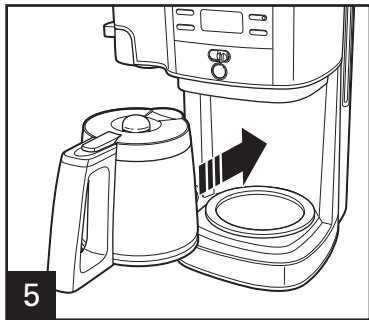

盖上瓶盖，将咖啡壶放在保温板上。

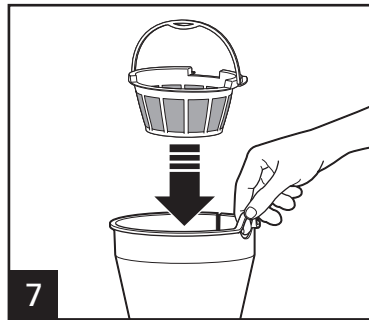
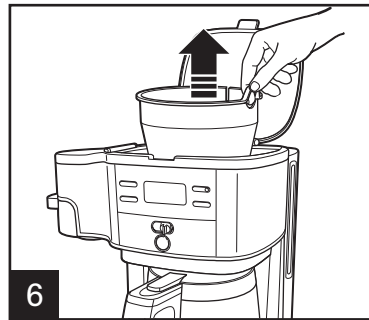

将永久过滤器放在咖啡篮中。也可
使用杯型纸质过滤器。

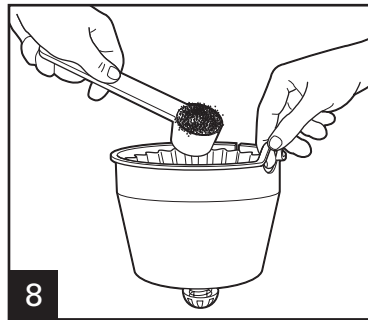

每冲泡一杯咖啡，则请将一咖啡勺
(15 毫升) 咖啡粉倒入过滤器。

如何使用咖啡壶式 (续)

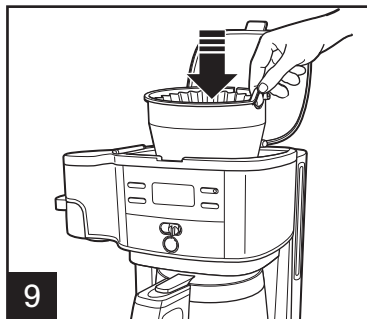

9

将咖啡篮放入咖啡机中。确保咖啡篮已放置妥当。

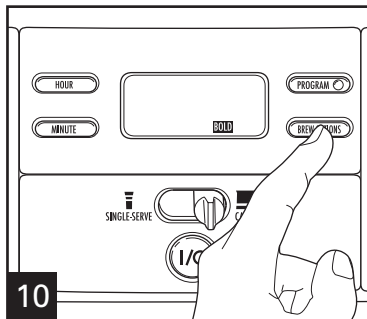

10

要冲泡浓郁咖啡/重口味咖啡，请按 **BREW OPTIONS (冲泡选项)**，直至显示 **BOLD (加浓)**。

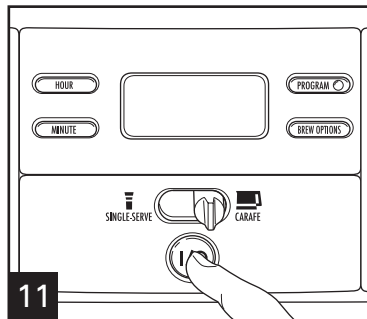

11

按 **I/O (开/关)** 按钮，开始冲泡。再按 **I/O (开/关)** 按钮，关闭咖啡机。
注意：如果咖啡机没有手动关闭，则咖啡机将在 2 小时后自动关闭。

要订购永久过滤器或其他部件和附件，请拨打：
800-820-6565
或登录 www.hamiltonbeach.cn

注意：**BOLD (加浓)** 模式需要额外时间来完成冲泡过程。如果没有选择 **BREW OPTIONS (冲泡选项)**，咖啡机将自动按常规/默认设置冲泡咖啡。

设置 (单杯式或咖啡壶式)

注意：咖啡机一次只可进行一侧冲泡。

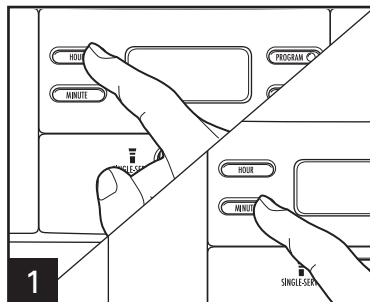

1 按 **HR / 小时**按钮，再按 **MIN / 分钟**按钮，设置时间。

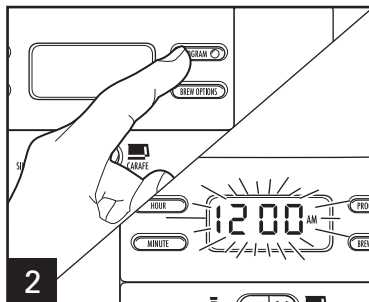

2 按住 **PROG / 预约**按钮直至时间闪烁。

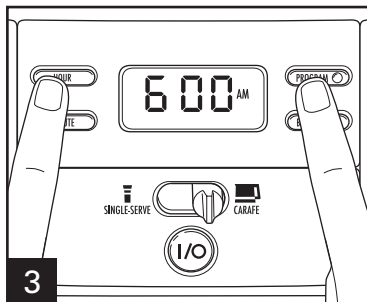

3 继续按住 **PROG / 预约**按钮，按 **HR / 小时**按钮和 **MIN / 分钟**按钮直至显示所需开始冲泡时间，然后释放 **PROG / 预约**按钮。

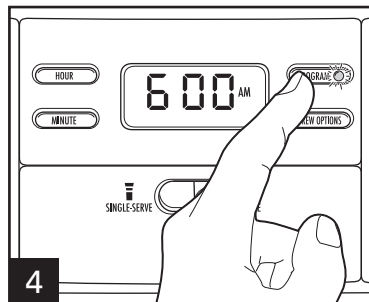

4 按下 **PROG / 预约**按钮，激活自动冲泡。绿色 LED 指示灯将会亮起，指示本咖啡机已完成设置。

冲泡美味咖啡的技巧

- 所有咖啡都是采用阿拉伯咖啡豆或罗布斯塔咖啡豆制造，或是两者的混合物。阿拉伯咖啡豆的价格略贵，但能冲泡出更美味的咖啡。
- 研磨咖啡粉比整豆更容易失去香味。如果购买已经磨好的咖啡，选择保质期最长或数量较小的包装袋。
- 若要研磨全豆咖啡，则将咖啡研磨机设置成精细/中度研磨状态。这将会产生口味最佳的研磨咖啡粉。最好使用在一个星期内研磨的新鲜咖啡粉。
- 使用水过滤器，过滤的水或瓶装水比自来水冲泡的咖啡口感更好。
- 每冲泡一杯咖啡，请使用约 1 咖啡勺咖啡粉。为避免溢出，冲泡脱因或调味咖啡时，请稍减咖啡粉用量 (3/4 咖啡勺 [11 毫升])。而且，请注意如果使用的咖啡粉研磨过于精细也可能导致咖啡溢出。
- 确保你的咖啡机保持干净。见“保养和清洁”章节。

护理和清洁—单杯式

所有咖啡机必须每个月至少清洗一次（硬水地区每周一次）。



将半杯（125 毫升）纯白醋和半杯（125 毫升）冷水倒入单杯式水箱。

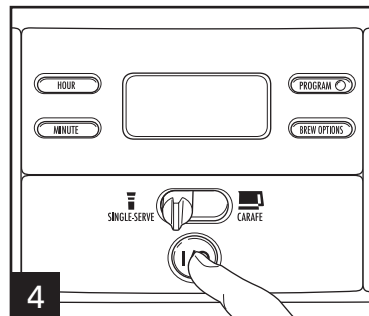
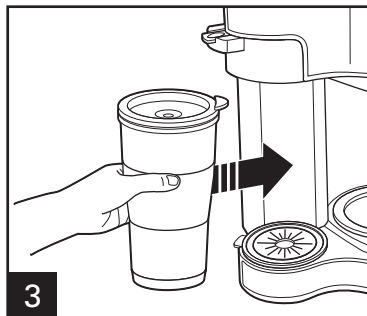
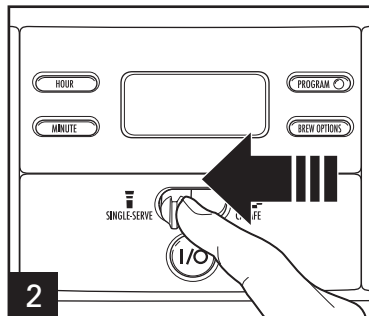

按 I (开) 按钮。30 秒后按 O (关) 按钮，并等候 30 分钟。按 I (开) 按钮。结束后按 O (关) 按钮。

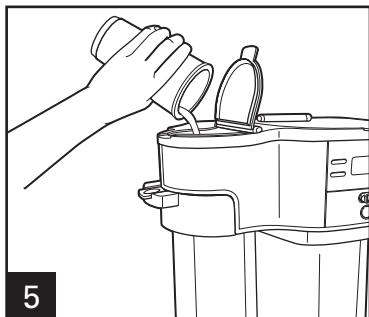

使用清水运行 2 到 3 个冲泡周期。每个周期之间需等咖啡机冷却后再运行。

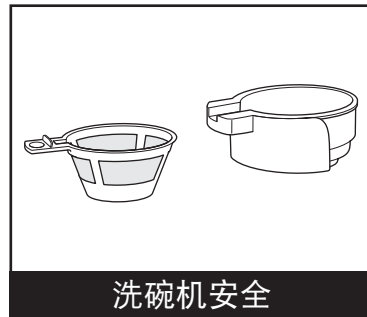
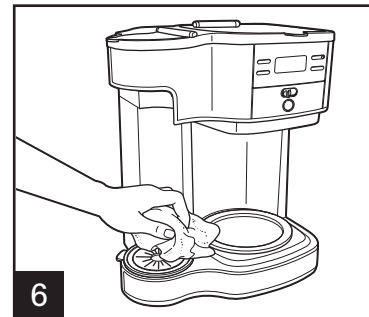

护理和清洁-咖啡壶式

所有咖啡机必须每个月至少清洗一次（硬水地区每周一次）。



1 将 1 品脱（2 杯/500 毫升）白醋倒入咖啡壶侧水箱。

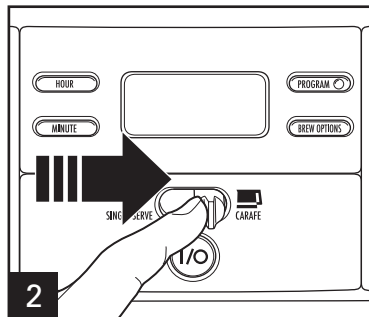

2



3

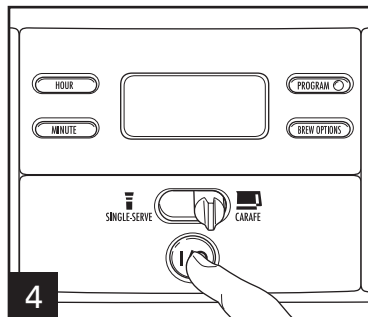

4 按 I (开) 按钮。30 秒后按 O (关) 按钮并等候 30 分钟。按 I (开) 按钮。结束后，按 O (关) 按钮。

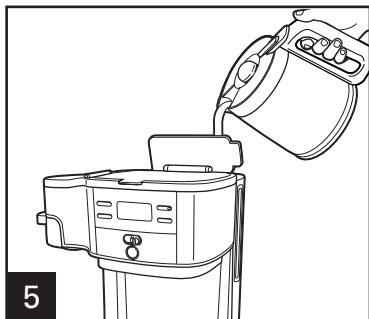

5 使用清水运行 2 到 3 个冲泡周期。每个周期之间需等咖啡机冷却后再运行。

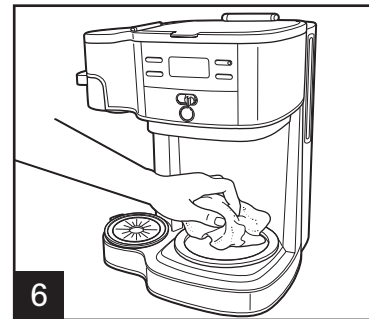

6

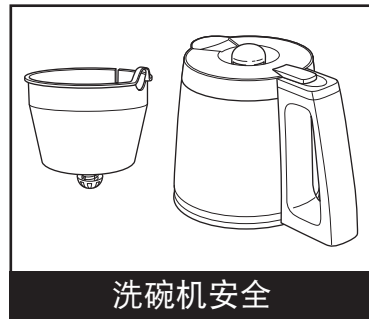

洗碗机安全

故障排除 (单杯式)

问题

可能原因

咖啡口味淡。

- 咖啡粉用量不够。参阅“如何使用单杯式”。

咖啡从咖啡篮、旅行马克杯或常规马克杯溢出。

- 水箱中的水过多。使用冲泡咖啡的旅行马克杯或常规马克杯装水倒入水箱。冲泡脱因或调味咖啡时，咖啡粉用量稍减。将咖啡研磨机设置成自动研磨档。

咖啡口味差。

- 需要清洗咖啡机。
- 咖啡粉太粗或太细。将咖啡研磨机设置成自动研磨档。
- 咖啡粉品质或新鲜度差。
- 水质不佳（采用过滤水或瓶装水）

故障排除 (咖啡壶式)

问题

咖啡溢出或咖啡冲泡慢

可能原因

- 咖啡粉过量。
- 脱因和（或）咖啡粉过细会导致溢出。将咖啡研磨机设置成自动研磨档。并稍减咖啡粉用量。
- 需要清洗咖啡机。

如使用纸质过滤器：

- 纸质过滤器和咖啡篮之间残留咖啡粉。
- 纸质过滤器未打开或位置不当。
- 插入纸质过滤器前，清洗咖啡篮，将咖啡篮边缘与过滤器边缘吻合。
- 纸质过滤器品质差。

咖啡滴漏在底座上。

- 冲泡周期中，咖啡壶从保温板上取走时间超过 20 秒。

咖啡口味差。

- 需要清洗咖啡机。
- 咖啡粉太粗或太细。将咖啡研磨机设置成自动研磨档。
- 咖啡粉与水的比率不均衡。依据个人喜好调整。
- 咖啡粉品质或新鲜度差。
- 水质不佳（采用过滤水或瓶装水）。

故障排除 (咖啡壶式) (续)

问题

可能原因

杯中有咖啡沉淀。

- 使用高质量、网篮式纸质过滤器替换永久咖啡过滤器。

咖啡无法冲泡或咖啡机无法开启。

- 咖啡壶在保温板上未放置妥当。
- 水箱没水。
- 未插上电源。
- 断电。
- 用电高峰。拔下插头，然后再重新插上。
- 断电后需重设时间。

冲泡时间比正常冲泡时间长。

- 矿物沉积物将会在咖啡机泵中累积。建议定期清洗咖啡机内部。根据水质硬度，可能需要更频繁清洗。参阅“护理和清洁-咖啡壶式”部分。
- 注意：**切勿拆卸本设备。

Model/型号:
49980-CN

Type/类别:
A77

Rating/规格
220V ~ 50Hz 950W

Dist.: Hamilton Beach Brands, Inc., Glen Allen, VA 23060
© 2016 Hamilton Beach Brands, Inc.

以上内容如有改动，恕不预先通知



添加官方微博 微信
开启美食人生

840199606