

READ BEFORE USE

使用前阅读

Visit www.hamiltonbeach.cn for our complete line of products and Use and Care Guides – as well as delicious recipes, tips, and to register your product online!

有关我们所有系列产品的使用与维护指南 – 以及美味食谱、生活小贴士和产品在线注册的更多信息，请访问 www.hamiltonbeach.cn。

Questions?

Please call us – our friendly associates are ready to help.

China: 400-852-2655

如有疑问？

请致电我们，我们的团队随时准备为您提供帮助。

中国大陆客服热线

400-852-2655

官方网站：www.hamiltonbeach.cn

型号：26030-CN

此说明书中图片仅供参考，产品以实物为准。

使用本设备前，我们建议您仔细阅读这些说明。

Hamilton 汉美驰 Beach®

Flip Belgian Waffle Maker 华夫饼炉

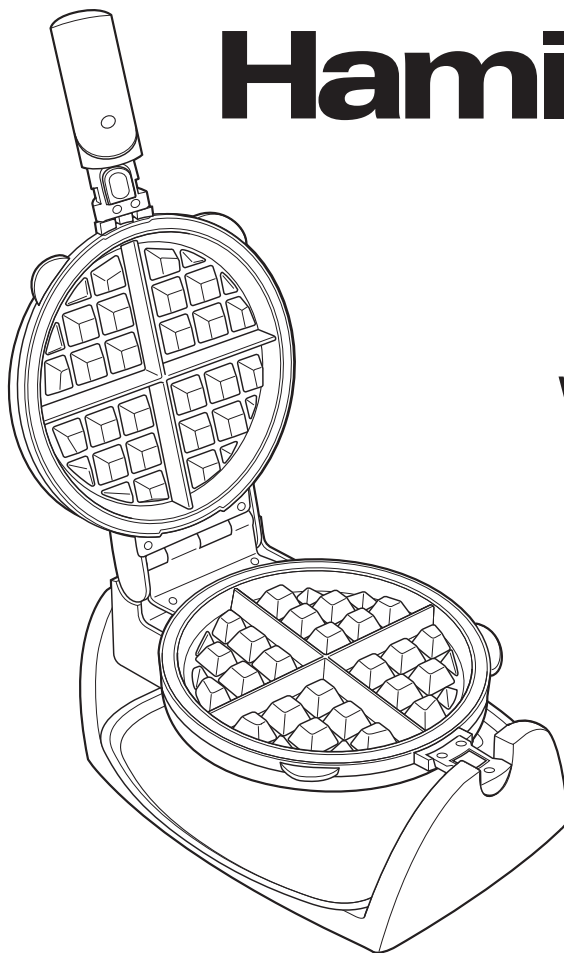

English2

简体中文9

IMPORTANT SAFEGUARDS

When using electrical appliances, basic safety precautions should always be followed to reduce the risk of fire, electric shock, and/or injury to persons, including the following:

1. Read all instructions.
2. This appliance is intended to be used in household and similar applications such as:
 - staff kitchen areas in shops, offices and other working environments;
 - farm houses;
 - by clients in hotels, motels and other residential type environments;
 - bed and breakfast type environments.
3. This appliance is not intended for use by persons (including children) with reduce physical, sensory, or mental capabilities, or lack of experience and knowledge, unless they are closely supervised and instructed concerning use of the appliance by a person responsible for their safety.
4. Do not touch hot surfaces. Use handles or knobs.
5. To protect against risk of electrical shock, do not immerse cord, plug, or any part of the appliance in water or other liquid.
6. Close supervision is necessary when any appliance is used by or near children.
7. Unplug from outlet when not in use and before cleaning. Allow to cool before putting on or taking off parts and before cleaning.
8. Do not operate any appliance with a damaged cord or plug, or after the appliance malfunctions or has been dropped or damaged in any manner. Call our toll-free customer service number for information on examination, repair, or adjustment. If the supply cord is damaged, it must be replaced by the manufacturer, its service agent or similarly qualified persons in order to avoid a hazard.
9. The use of accessory attachments not recommended by the appliance manufacturer may cause injuries.
10. Do not use outdoors.
11. Do not let cord hang over edge of table or counter or touch hot surfaces, including the stove.
12. Do not place on or near a hot gas or electric burner, or in a heated oven.
13. Extreme caution must be used when moving an appliance containing hot oil or other hot liquids.
14. Do not use appliance for other than intended use.
15. Do not use appliance unattended.
16. During use, provide 4 to 6 inches air space above, behind, and on both sides for air circulation.
17. Never remove the waffle with any kind of cutting device or other metallic kitchen utensil.
18. Always allow the appliance to cool before putting it away, and never wrap the cord around the appliance while it is still hot.
19. Some surfaces are very hot when the appliance is working.
20. **CAUTION:** In order to avoid a hazard due to inadvertent resetting of the thermal cut-out, this appliance must not be supplied through an external switching device, such as a timer, or connected to a circuit that is regularly switched on and off by the utility.

SAVE THESE INSTRUCTIONS!

Other Consumer Safety Information

This product is intended for household use only.

The length of the cord used on this appliance was selected to reduce the hazards of becoming tangled in or tripping over a longer cord. If a longer cord is necessary, an approved extension cord may be used. The electrical rating of the extension cord must be equal to or greater than the rating of the appliance. If the appliance is provided with a grounded cord, the

extension cord must also be a grounding 3-wire cord. Care must be taken to arrange the extension cord so that it will not drape over the countertop or tabletop where it can be pulled on by children or accidentally tripped over.

To avoid an electrical circuit overload, do not use another high-wattage appliance on the same circuit with this appliance.

Parts and Features

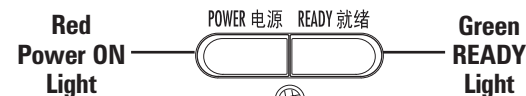
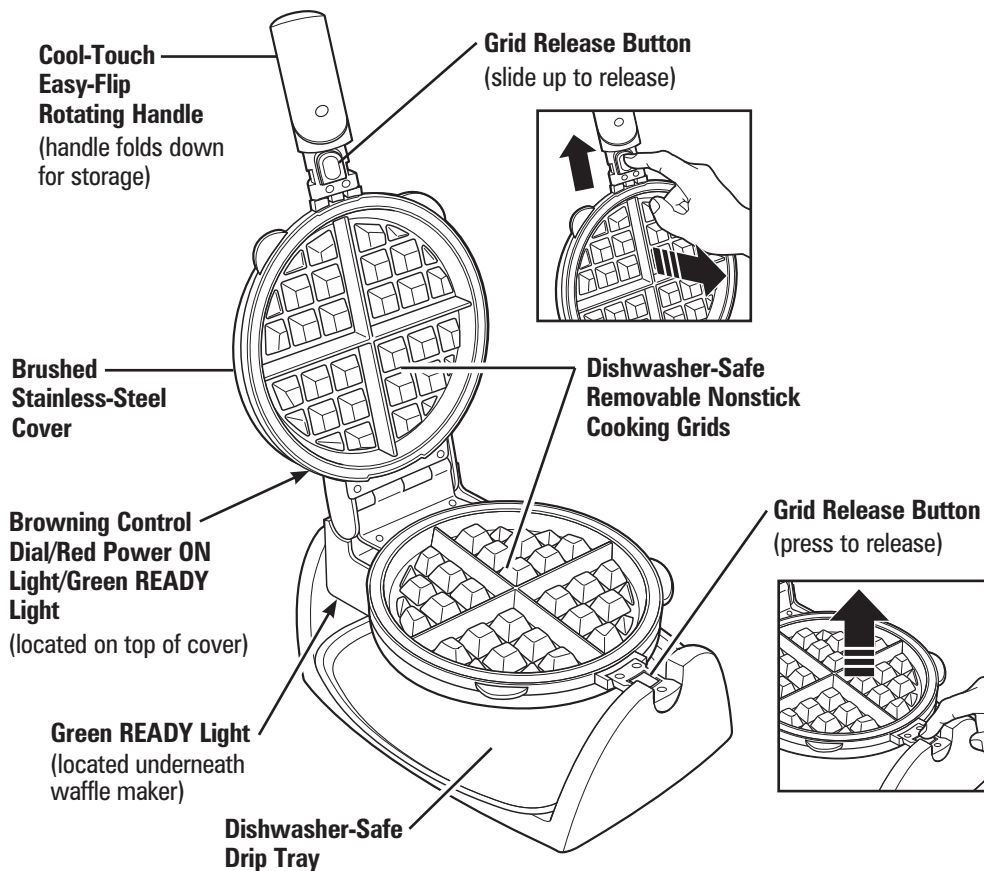

Browning Control Dial

READY



Green READY Light
(located underneath waffle maker)

The red Power ON light comes on when the appliance is first plugged in. This light will stay on until the unit is unplugged.

The green READY lights come on when the appliance has reached the desired temperature. For best results, wait until green READY lights come on before adding waffle batter. These lights will cycle on and off during baking.

How to Use

BEFORE FIRST USE: Wipe the bottom and top cooking grids with a soapy, damp cloth. Rinse cloth; then wipe grids again. Wipe or brush waffle grids with vegetable oil. This is only recommended before first use. Waffle browning will improve with each subsequent batch. Cooking grids are dishwasher-safe.

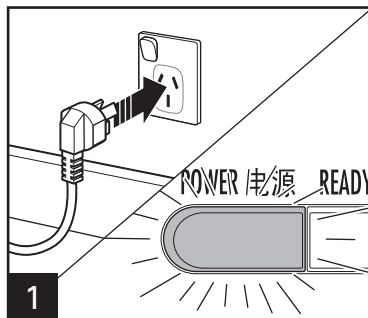

1 Plug cord into electrical outlet. The red Power ON light will glow. **TIP:** A small amount of nonstick cooking spray, oil, or butter can be used on the grids before preheating.

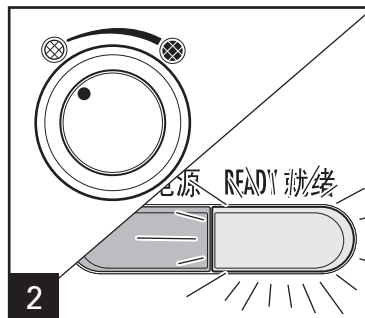

2 Choose desired browning control setting and preheat with cover closed until the green READY light comes on.

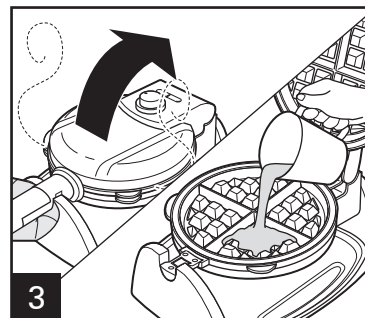

3 With control dial facing up, move handle straight up to raise cover. **NOTE:**

- Lifting the handle is easy and doesn't require force. Rotating the handle the wrong way will break the unit. See arrow on handle for direction.
- Pour about 1 cup (250ml) of batter into center of grids, allowing batter to spread.

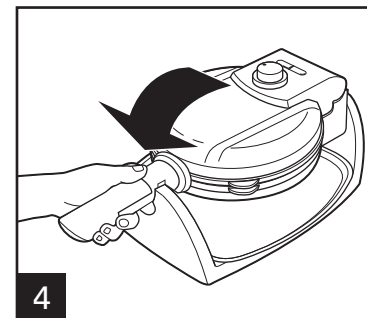

4 Close cover. **NOTE:** Too much batter on grids may cause overflow.

How to Use (cont.)

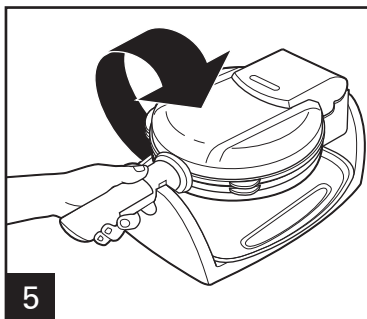

Within 10 seconds of closing cover, rotate handle to the right to lock cover into place. Control Dial will be on the bottom. **NOTE:** Rotating is easy and doesn't require force.

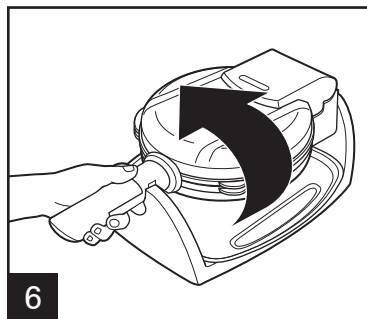

Once the waffle is done (about 5–8 minutes) or when steaming begins to stop, rotate the handle again by turning it to the left. **NOTE:** Rotating is easy and doesn't require force.

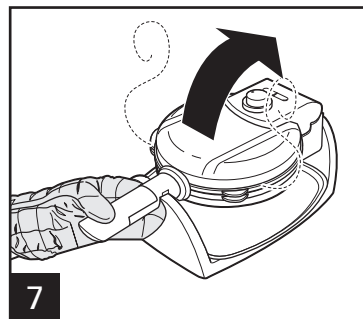

Control dial should now be on top. Using an oven mitt, lift handle straight up to open. **NOTE:** Lifting the handle is easy and doesn't require force.

⚠ WARNING Burn Hazard. Always use an oven mitt to protect hand when opening a hot waffle maker. Escaping steam can burn.

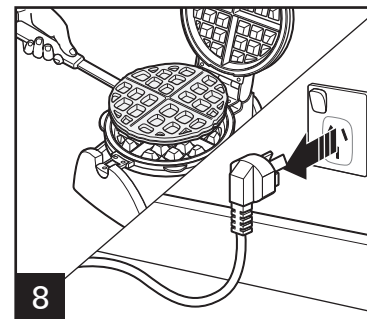

Remove waffle with plastic or wooden utensil. Never use metal. This will damage the nonstick coating of the appliance. Unplug unit when through cooking. Let cool completely before removing cooking grids. **NOTE:** Always use the grid release button to remove the grids.

Suggested Toppings and Spreads for Waffles

Maple Syrup
Chocolate Syrup
Powdered Sugar
Honey
Jams and Jellies

Cinnamon Sugar
Maple Butter
Apple Butter
Whipped Cream
Applesauce

Brown Sugar
Chocolate Sprinkles
Cake Frosting
Peanut Butter

Suggested ideas to stir into batter before cooking: small pieces of fresh fruit, dried fruit, chocolate chips, chocolate covered raisins, or nuts.
TIP: Certain fresh fruits like blueberries will turn batter blue. Do not stir into batter; sprinkle over batter before cooking.

Recipes

Basic Waffles

2 cups flour	1 3/4 cups milk
2 tablespoons sugar	1/3 cup vegetable oil
1 tablespoon baking powder	2 eggs
1 teaspoon salt	

Combine flour, sugar, baking powder and salt. Stir together milk, oil and eggs. Gradually add milk mixture to the dry ingredients. Stir until just blended. Pour 1 cup (250ml) of batter into center of grids, allowing batter to spread. **Serves:** 2

Blueberry Waffles: After pouring batter onto waffle plates, sprinkle fresh blueberries over batter; then close lid. Do not stir berries into batter; this makes blue-gray waffles.

To Make a Savory Waffle: Add your favorite freshly chopped or dried savory spices to the batter.

Simple Recipe

1 1/2 cup low-gluten cake flour	1 1/2 cup milk
5 tablespoons sugar	2 eggs
Pinch of salt	

Combine flour, sugar and salt. Stir together milk and eggs. Gradually add milk mixture to the dry ingredients. Stir until just blended. Pour about 1 cup (250ml) of batter into center of grids, allowing batter to spread. **Serves:** 2

Care and Cleaning

⚠ WARNING Electrical Shock Hazard.

Disconnect power before cleaning. Do not immerse cord, plug, or base in any liquid.

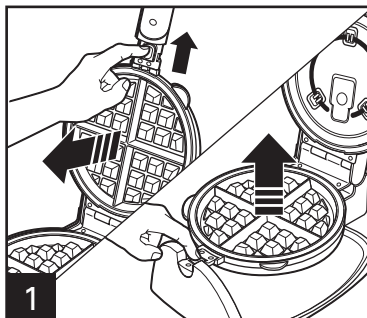

1 Unplug unit and allow to cool completely before removing grids. For the upper grid, slide latch away from grid to release. For lower grid, press button to release.

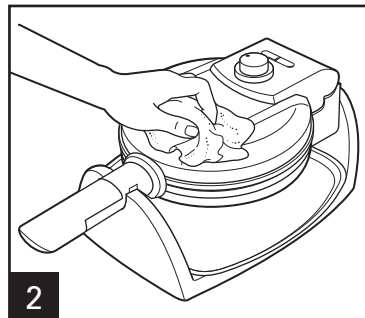

2 Wipe outside of unit with a damp, soapy cloth. Do not use steel wool, scouring pads, or abrasive cleansers on any part of the unit. Never use sharp or pointed objects for cleaning purposes.

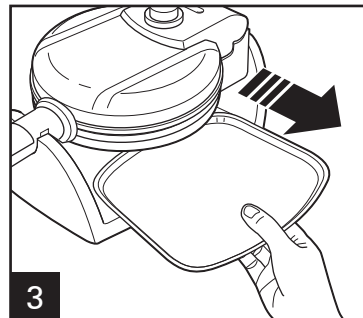

3 Clean drip tray by rinsing off excess overflowed batter with hot water; then use soapy cloth to clean drip tray and rinse again with hot water.



DISHWASHER-SAFE
DO NOT use the "SANI" setting when washing in the dishwasher. "SANI" cycle temperatures could damage your product.

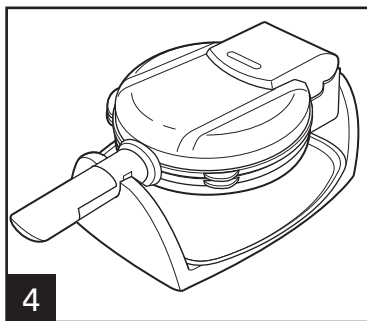

4 Always allow the appliance to cool down completely and lock the lid by rotating the handle before storing.

Usage Tips

- To make your family a quick, hot breakfast, use any of the waffle mixes currently available on the market.
- Save additional time in the morning by preparing waffle batter the night before and refrigerating it. Make sure waffle batter reaches room temperature before use. Using fresh batter results in fluffier waffles.
- Use a cooking spray before pouring batter into the grids, especially for dessert waffles or recipes with a lot of sugar.
- If your waffles start to stick, the grids may need to be scrubbed with a nylon brush to remove any cooked-on food particles.
- If using nuts in waffle batter, use chopped nuts and/or evenly spread batter to allow lid to fully close.
- Waffles can be made ahead of time and kept warm in a 200°F (93°C) oven.
- Most waffles are done in about 6 minutes, depending on the setting selected. Some of the recipes which are made from scratch may take a little longer. Check for doneness at about 6 minutes. If the cover of the waffle maker doesn't lift up easily, then let the waffle cook a minute more before checking again. Another indicator that the waffle is done is when the steaming stops.
- To store, let waffles cool and pack in an airtight container; store in refrigerator or freezer for reheating later.
- Reheat in a microwave oven, a toaster oven, or a regular oven.

重要安全说明

在使用该设备时，应始终遵守基本的安全防范措施，以减少火灾、触电和/或人身伤害的风险，包括以下内容：

1. 阅读所有相关说明。
2. 本电器预定用于家用及类似应用场合，例如：
 - 办公室、商铺及其它工作环境的员工厨房区；
 - 农舍；
 - 酒店、汽车旅馆和其它居住型环境的旅客使用；
 - 以及住宿早餐型环境场合。
3. 本电器不适合以下人群（包括儿童）使用：行动不便者、精神或智商缺陷者、缺少经验和常识者，除非他们在监护人的密切监督和指导下使用，以确保安全。
4. 请勿接触发热表面。应使用手柄或旋钮。
5. 请勿将电源线、插头或该设备的任何部件浸泡在水或其他液体之中，以免发生电击危险。
6. 使用或在儿童附近使用该设备时，一定要密切监督。
7. 不使用与清洁前，请拨下电源插头。拆装部件前以及清洁前，必须让设备冷却。
8. 在下列情况下，请勿使用设备：电源线或插头破损、或设备出现故障后、设备曾跌落或已经出现任何形式的损坏。请拨打我们的免费售后服务电话，咨询有关电器检查、修理或调整的相关信息。如果电源线损坏，为了避免危险，必须由制造商、其维修部或类似部门的专业人员更换。
9. 使用非设备制造商推荐的配套附件可能会带来伤害。
10. 请勿户外使用。
11. 请勿将电源线搭置在桌台边缘上以及与发热表面接触，包括加热器。
12. 请勿靠近或放置在燃气或电炉上，或放进加热烤箱内。
13. 当移动含有热油或其他热液体的设备时，应特别小心。
14. 请勿将设备用作其他非预期用途。
15. 请勿无人看管下使用该设备
16. 在使用过程中,在设备上方、后方以及两侧预留10-15厘米空间，让空气流通。
17. 禁止使用任何剪切设备或其他金属炊具取下华夫饼。
18. 存放前，务必让设备冷却。当设备仍热时禁止将电源线缠绕在设备上。
19. 设备工作期间，某些表面的温度很高。
20. **小心：**为了避免由于热熔断器意外重置导致危险，本电器不能在外接定时器或独立的遥控控制系统的方式下运行。

请妥善保管这些说明！

其他用户安全信息

本产品建议家庭使用。

本设备电源线的长度设计考虑减少长电源线缠绕或绊倒的危险。倘若需要更长的电源线，可使用批准的电源延长线。电源延长线的额定功率必须等于或大于此设备的额定功率。如果该设备配有接地型电源

线，电源延长线也必须使用接地型3相电源线。电源延长线使用时需特别注意，以防将其搭设在桌台上，造成儿童扯拉或绊倒他人。为防电路过载，请勿在此电器的同一电路上使用其他高功率电器。

部件和功能

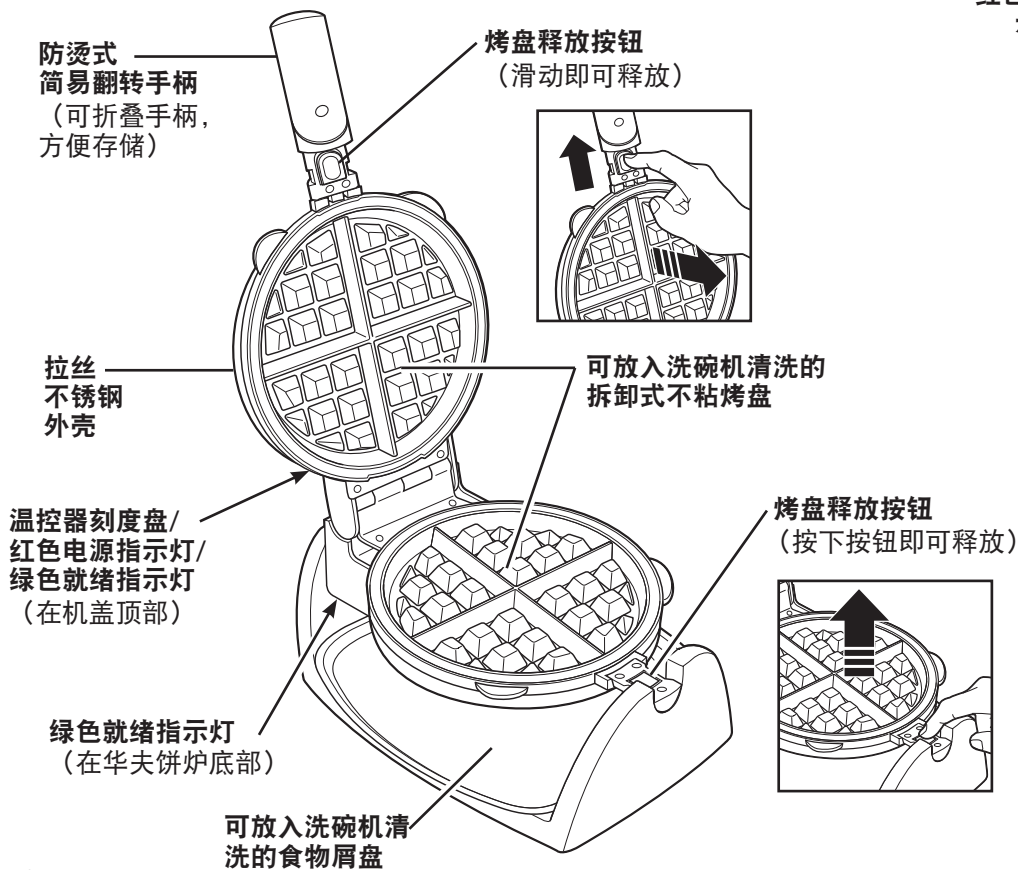

红色电源指
示灯

POWER 电源 READY 就绪

绿色就绪
指示灯

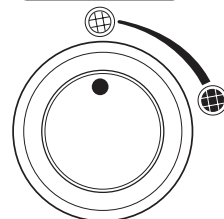

温控器刻度盘

READY



绿色就绪指示灯
(在华夫饼炉底部)

当本设备初次接通电源时，红色电源指示灯亮起。该灯将一直亮起直至拔下插头。

当机器达到所需温度时，绿色就绪指示灯亮起。为达到最佳效果，请在绿色就绪指示灯亮起后再添加华夫饼面糊。烘焙时，这两个灯将循环亮起和熄灭。

如何使用

首次使用前：请使用蘸清洁剂的湿布擦拭烤盘底部和顶部。将布清洗干净；然后再次擦拭烤盘。使用植物油擦拭或刷洗华夫烤盘。建议仅在初次使用前采用上述清洗方法。后续每一批华夫饼烘焙质量将会提高。烤盘可放入洗碗机清洗。

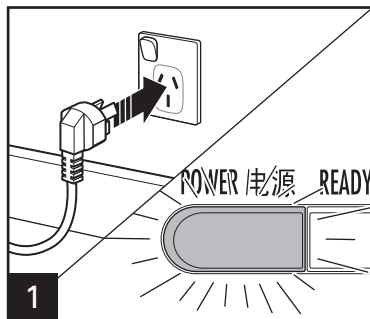

将电线插头插入电源插座。
红色电源指示灯将点亮。

小贴士：在预热前可能需要在烤盘上涂上少量不粘锅烹饪植物油、食用油或黄油。

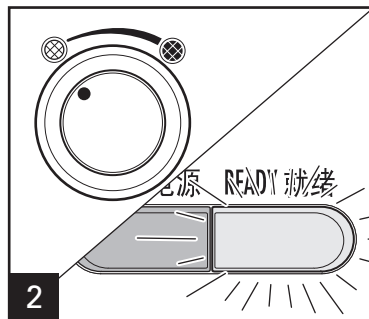

选择所需温控设置，盖上机盖预热直至绿色就绪指示灯亮起。

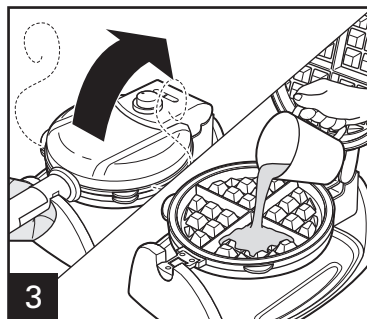

温控器刻度盘面朝上时，上掀打开机盖。

注意：

- 手柄能轻松提起，不费力。错误方向旋转手柄将会损坏本设备。看手柄上的箭头方向。
- 将约1杯（250毫升）面糊倒入烤盘中心，让面糊散开，均匀填满烤盘。

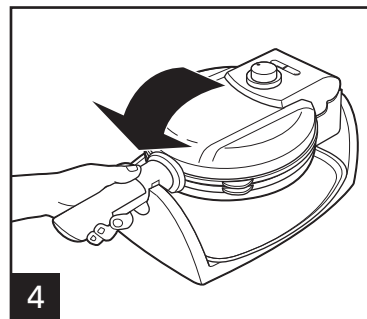

然后合上机盖。**注意：**不要往烤盘中倒入太多面糊，因为他们可能会溢出。

如何使用 (续)

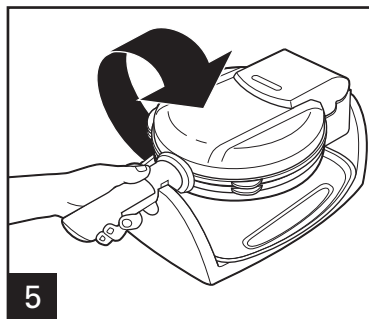

5 盖上门盖10秒钟内，向右旋转手柄把机盖锁定。温控器刻度盘将处于底部。**注意：**轻松旋转，不费力。

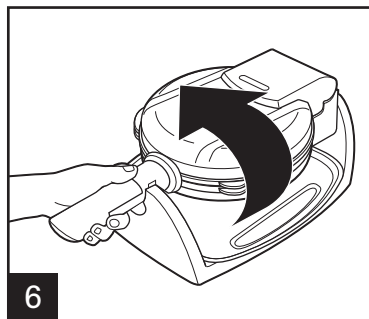

6 华夫饼在5至8分钟内烘焙完成后或停止出蒸汽时，再次向左旋转手柄。**注意：**轻松旋转，不费力。

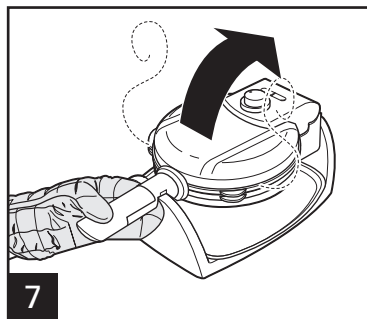

7 现在温控器刻度盘应位于顶部。戴上烤箱手套，上掀打开机盖。**注意：**手柄能轻松提起，不费力。

警告 灼烧风险。

每次打开炙热的华夫机时，请佩戴微波炉手套以保护双手。逸出的蒸汽会造成烫伤。

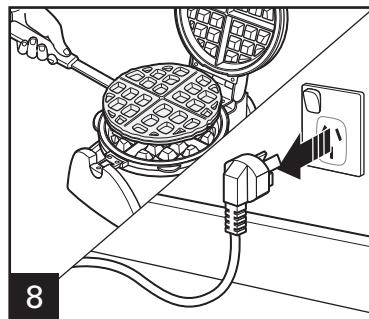

8 使用塑料或木制工具取走华夫饼。切勿使用金属。这将会损坏设备的不粘涂层。烘焙完成后，请拔下电源插头。取下烤盘前，让其完全冷却。**注意：**务必通过操作烤盘释放按钮取下烤盘。

建议的华夫饼配料和酱

枫糖浆
巧克力糖浆
糖粉
蜂蜜
果酱和果冻

肉桂糖
枫叶黄油
苹果酱
鲜奶油
苹果沙司

红糖
巧克力粉
蛋糕糖霜
花生酱

烘焙前建议混合面糊的配料：少量的新鲜水果、干果、巧克力饼、葡萄干或坚果。

小贴士：某些新鲜水果，例如蓝莓，会使面糊变蓝。请勿混合到面糊中，可在烘焙前撒在面糊上。

食谱

一般华夫饼

中筋面粉	1.5杯(180克)	盐	¼茶匙
糖	¼杯(50克)	酸奶	1¼杯(295毫升)
粟米粉	¼杯(28克)	鸡蛋	2个
泡打粉	2茶匙	融化黄油	半杯(113克)
梳打粉	半茶匙	香草精	1茶匙

先将面粉、糖、泡打粉和盐等干食材混合。将牛奶、植物油和鸡蛋一起搅拌。逐渐添加牛奶混合物到干的面粉配料上。搅拌直到均匀。将约1杯(250毫升)面糊倒入烤盘中心，让面糊散开，均匀填满烤盘。
份量：2

蓝莓华夫饼：将面糊倒入到华夫饼烤盘后，撒些新鲜的蓝莓在面糊上，然后盖上机盖。请勿将草莓搅拌进入到面糊中，这会烘焙出青灰色的华夫饼。

制作美味的华夫饼：将您喜欢的切碎或干的美味配料添加到面糊中。

简易食谱

低筋粉	180克	鸡蛋	1-2个
牛奶	180毫升	盐	少许
糖	75克		

先将面粉、糖和盐等干食材混合。将牛奶和鸡蛋一起搅拌。逐渐添加牛奶混合物到干的面粉配料上。搅拌直到均匀。将约1杯(250毫升)面糊倒入烤盘中心，让面糊散开，均匀填满烤盘。**份量：2**

护理及清洁

警告

触电危险。

清洗前，请断开电源。请勿将电源线、插头或主机浸入任何液体中。

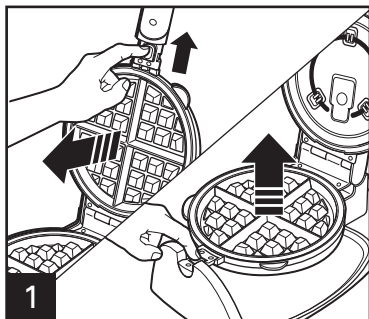

1 请先拔下插头并让机器完全冷却后，再移走烤盘。对于顶部烤盘，请滑动锁扣释放烤盘。对于底部烤盘，请按下按钮进行释放。

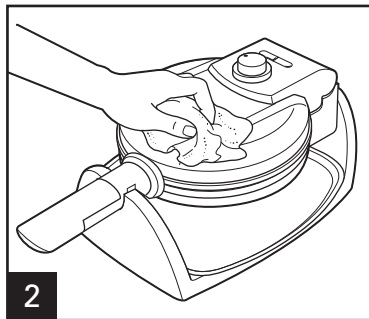

2 请用蘸清洁剂的湿布擦拭设备外部。
严禁使用钢丝绒、百洁布或磨砂清洁剂擦洗设备的任何部位。严禁使用锋利或尖锐物体清洗设备。

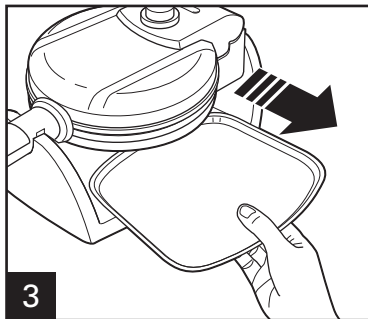

3 使用热水清除多余溢出的面糊，然后使用蘸清洁剂的布清洁食物屑盘并再次用热水冲洗。

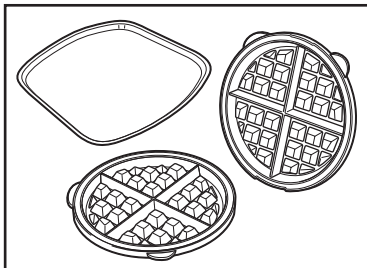

可放入洗碗机清洗

放入洗碗机清洗时，严禁使用“SANI”设置。“SANI”循环温度会损坏本产品。

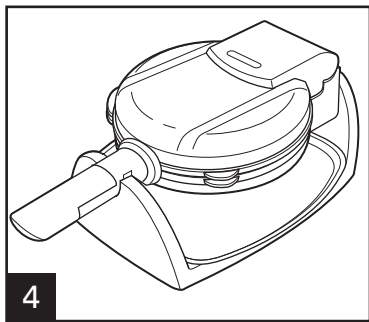

4 每次储存前，请让设备完全冷却并旋转手柄，锁住机盖。

使用小贴士

- 使用市场上任何现有的华夫饼调料，为您的家人快速烹制热腾腾的早餐。
- 前一晚上准备好华夫饼面糊并冷藏，次日早晨即可节省额外时间。使用前，请确保华夫饼面糊达到室温。使用新鲜面糊将烘焙出更为松软的华夫饼。
- 往烤盘刷上烹饪喷雾油后，再倒入面糊，尤其是甜味华夫饼或多糖配方。
- 如果您的华夫饼开始粘连烤盘，可能需要使用尼龙刷清洗烤盘，从而清除烘焙残留的食物残渣。
- 如果华夫饼面糊中添加坚果，请使用碎状坚果或均匀地将坚果散在面糊中，以让机盖完全盖住。
- 华夫饼可提前制作并在200°F(93°C)的烤箱中进行保温。
- 根据所选择的设置，大部分华夫饼需要约6分钟时间烘焙完成。部分需要重头开始制作的配方可能需要稍长时间。约6分钟后查看是否烘焙完成。如果华夫机盖不容易提取，则让华夫机多烘焙一分钟后再查看。当蒸汽停止时，表示华夫饼制作完成。
- 要储藏华夫饼，请让其冷却后再使用密闭容器打包；存放于冰箱或冷冻箱，以后再重新加热。
- 使用微波炉、烤炉或一般烤箱重新加热。

Model/型号:
26030-CN

Type/类别:
WB09

Rating/规格
220V ~ 50Hz 800W

Dist.: Hamilton Beach Brands, Inc., Glen Allen, VA 23060
© 2012 Hamilton Beach Brands, Inc.

以上内容如有改动，恕不预先通知



添加官方微博 微信
开启美食人生

840216105