

**READ BEFORE USE**

**使用前阅读**

Visit [www.hamiltonbeach.cn](http://www.hamiltonbeach.cn) for our complete line of products and Use and Care Guides – as well as delicious recipes, tips, and to register your product online!

有关我们所有系列产品的，使用与维护指南 – 以及美味食谱、生活小贴士和产品在线注册的更多信息，请访问 [www.hamiltonbeach.cn](http://www.hamiltonbeach.cn)。

**Questions?**

**Please call us – our friendly associates are ready to help.**  
**China: 400-852-2655**

**如有疑问？**

**请致电我们，我们的团队随时准备为您提供帮助。**

**中国大陆客服热线：**

**400-852-2655**

**官方网站：[www.hamiltonbeach.cn](http://www.hamiltonbeach.cn)**

**型号：C33101**

**此说明书中图片仅供参考，产品以实物为准。**

使用本设备前，我们建议您仔细阅读这些说明。

# Hamilton 汉美驰 Beach®

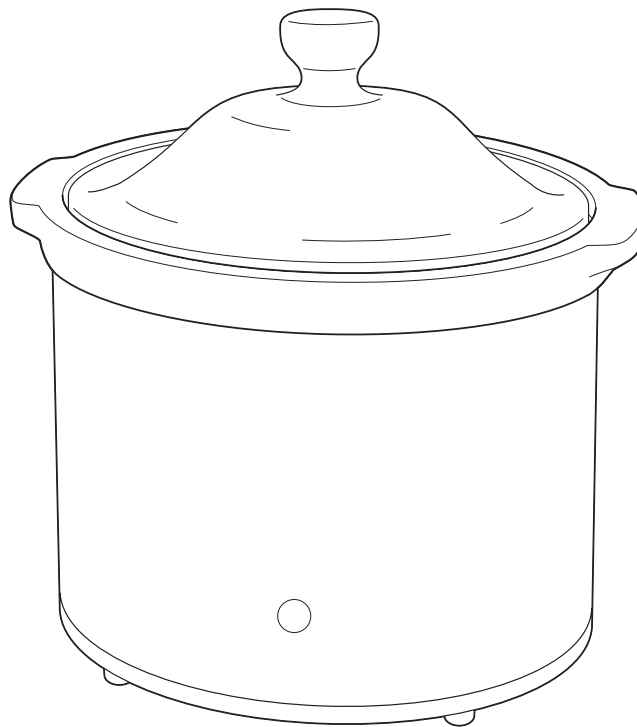

## Slow Cooker 慢炖锅

English ..... 2

简体中文 ..... 7

# IMPORTANT SAFEGUARDS

When using electrical appliances, basic safety precautions should always be followed to reduce the risk of fire, electric shock, and/or injury to persons, including the following:

1. Read all instructions.
2. This appliance is intended to be used in household and similar applications such as:
  - staff kitchen areas in shops, offices and other working environments;
  - farm houses;
  - by clients in hotels, motels and other residential type environments;
  - bed and breakfast type environments.
3. This appliance is not intended for use by persons (including children) with reduce physical, sensory, or mental capabilities, or lack of experience and knowledge, unless they are closely supervised and instructed concerning use of the appliance by a person responsible for their safety.
4. Do not touch hot surfaces. Use handles or knobs.
5. To protect against electric shock, do not immerse cord, plug, or base in water or other liquid.
6. Close supervision is necessary when any appliance is used by or near children.
7. Unplug from outlet when not in use and before cleaning. Allow to cool before putting on or taking off parts.
8. Do not operate any appliance with a damaged cord or plug, or after the appliance malfunctions or is dropped or damaged in any manner. Call our customer service number for information on examination, repair, or adjustment. If the supply cord is damaged, it must be replaced by the manufacturer, its service agent or similarly qualified persons in order to avoid a hazard.
9. The use of accessory attachments not recommended by the appliance manufacturer may cause injuries.
10. Do not use outdoors.
11. Do not let cord hang over edge of table or counter, or touch hot surfaces, including stove.
12. Do not place on or near a hot gas or electric burner, or in a heated oven.
13. Extreme caution must be used when moving an appliance containing hot oil or other hot liquids.
14. To disconnect slow cooker, turn control knob to OFF (O); then remove plug from wall outlet.
15. **CAUTION:** To prevent damage or shock hazard, do not cook in base. Cook only in removable crock.
16. Avoid sudden temperature changes, such as adding refrigerated foods into a heated crock.
17. Do not use appliance for other than intended use.
18. **CAUTION:** In order to avoid a hazard due to inadvertent resetting of the thermal cut-out, this appliance must not be supplied through an external switching device, such as a timer, or connected to a circuit that is regularly switched on and off by the utility.

## SAVE THESE INSTRUCTIONS!

### OTHER CONSUMER SAFETY INFORMATION

**This product is intended for household use only.**

This product is only intended for the preparation, cooking, and serving of foods. This product is not intended for use with any non-food materials or products.

The length of the cord used on this appliance was selected to reduce the hazards of becoming tangled in or tripping over a longer cord. If a longer cord is necessary, an approved extension cord may be used. The electrical rating of the extension cord must be equal to or greater than the rating of the appliance. Care must be taken to arrange the extension cord so that it will not drape over the countertop or tabletop where it can be pulled on by children or accidentally tripped over.

## LID AND CROCK: PRECAUTIONS AND INFORMATION

- Please handle crock and lid carefully to ensure long life.
- Avoid sudden, extreme temperature changes. For example, do not place a hot lid or crock into cold water, or onto a wet surface.
- Avoid hitting crock or lid against faucet or other hard surfaces.
- Do not use crock or lid if chipped, cracked, or severely scratched.
- Do not use abrasive cleansers or metal scouring pads.
- The bottom of crock is very rough and can damage countertop. Use caution.
- The crock and lid can become very hot. Use caution. Do not place directly on any unprotected surface or countertop.
- The crock is microwave-safe and oven-proof, but never heat crock when empty. Never place lid on a burner or stove top. Do not place lid in a microwave oven, conventional oven, or on stove top.

## REMOVING LID AND CROCK

When removing lid, tilt so that opening faces away from you to avoid being burned by steam.

The sides of the slow cooker's base get very warm because the heating elements are located here. Use handles on base if necessary. Use oven mitts to remove crock.

# Parts and Features

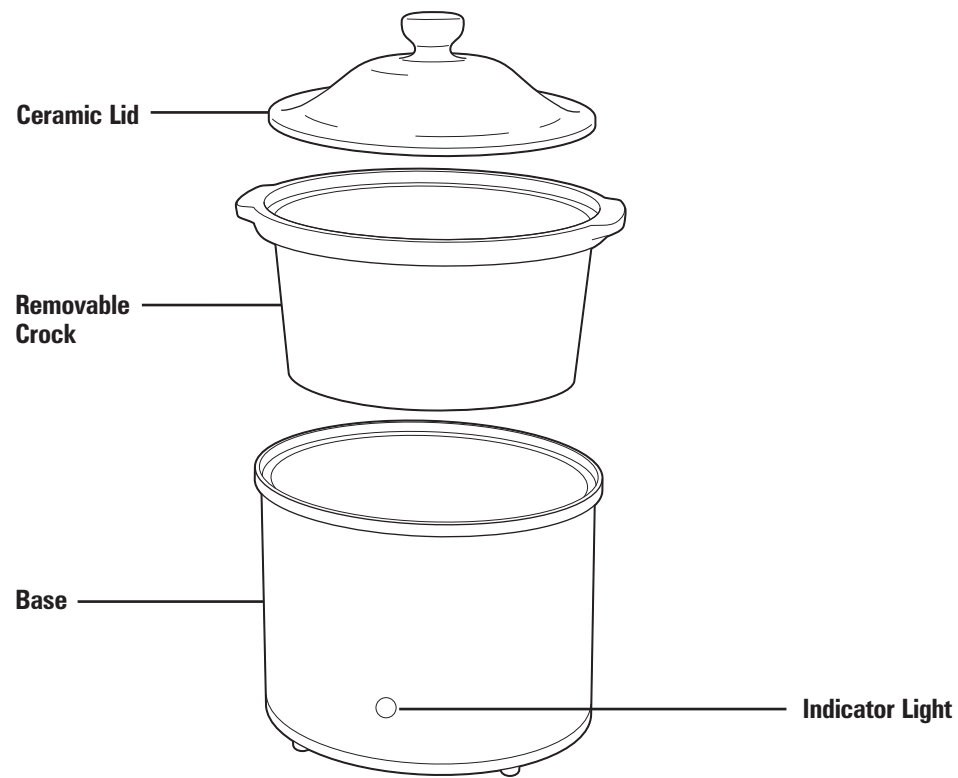

# How to Use Your Slow Cooker

**BEFORE FIRST USE:** Wash lid and crock in hot, soapy water. Rinse and dry.

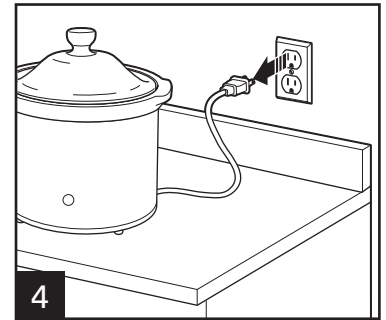
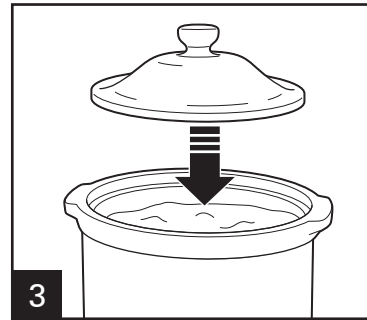
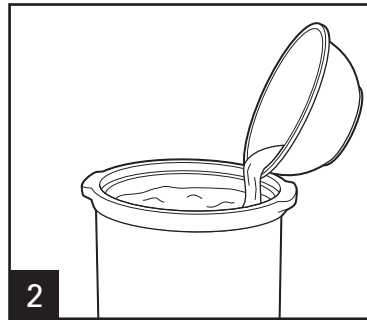
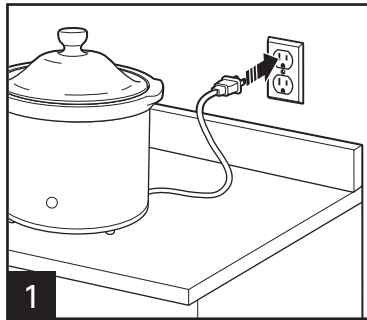

When finished, unplug base. Let crock and lid cool slightly before washing.

## Tips for Slow Cooking

- The crock should be at least half-filled for best results. If only half-filled, check for doneness 1 to 2 hours earlier than recipe time.
- Stirring is not necessary when slow cooking. Removing glass lid results in major heat loss and the cooking time may need to be extended.
- If cooking soups or stews, leave a 2-inch (5-cm) space between the top of the crock and the food so that the recipe can come to a simmer.
- Many recipes call for cooking all day. If your morning schedule doesn't allow time to prepare a recipe, do it the night before. Place all ingredients in crock, cover with lid, and refrigerate overnight. In the morning, simply place crock in slow cooker.
- Some foods are not suited for extended cooking in a slow cooker. Pasta, seafood, milk, cream, or sour cream should be added 2 hours before serving. Evaporated milk or condensed soups are perfect for slow cooking.
- The higher the fat content of meat, the less liquid is needed. If cooking meat with a high fat content, place thick onion slices underneath so meat will not sit on (and cook in) fat.
- Slow cookers allow for very little evaporation. If making your favorite soup, stew, or sauce, reduce liquid called for in original recipe. If too thick, liquid can be added later.
- If cooking a vegetable-type casserole, there will need to be liquid in the recipe to prevent scorching on the sides of crock.
- If cooking a recipe with root vegetables, place root vegetables in the bottom of the crock.

# Cleaning and Care

**⚠ WARNING**

**Electrical Shock Hazard.**

Disconnect power before cleaning. Do not immerse cord, plug, or base in any liquid.

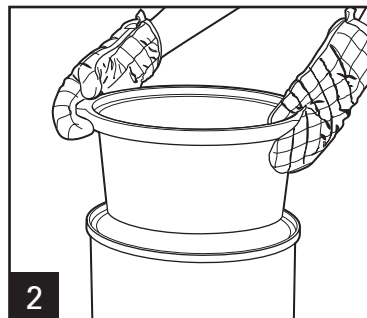
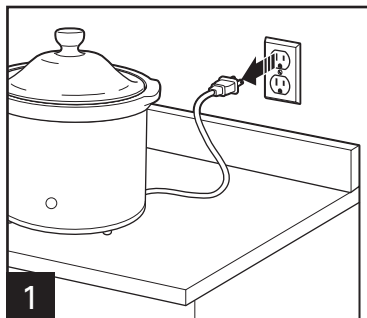

Remove crock and let cool.

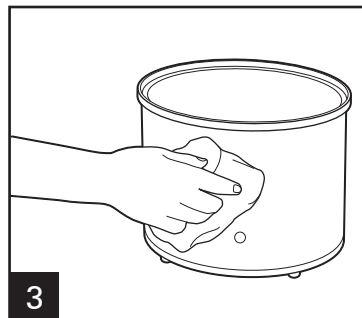

DO NOT use the "SANI" setting when washing in the dishwasher. "SANI" cycle temperatures could damage your product.

# 重要安全说明

当使用带电设备时，为降低火灾、电击风险以及对个人造成的伤害，请注意基本的安全预防措施，具体如下：

1. 阅读所有说明。
2. 本电器预定用于家用及类似应用场合，例如：
  - 办公室、商铺及其它工作环境的员工厨房区；
  - 农舍；
  - 酒店、汽车旅馆和其它居住型环境的旅客使用；
  - 以及住宿早餐型环境场合。
3. 本电器不适合以下人群（包括儿童）使用：行动不便者、精神或智商缺陷者、缺少经验和常识者，除非他们在监护人的密切监督和指导下使用，以确保安全。
4. 请勿接触设备热表面，请使用把手或者旋钮。
5. 为防止电击危险，请勿将设备的线缆、插头、或底座浸入水或其他液体中。
6. 当设备由儿童使用、或在其附近使用时，应予以密切监护。
7. 在设备不工作时及清理前，请从插座中拔出插头。待设备冷却后，方能增加或移除部件。
8. 请勿使用任何损坏的线缆或插头操作设备，或在设备故障、跌落或因任何方式损坏后使用。请拨打我们的客户服务电话以获取检查、修理或调整的相关信息。如果电源软线损坏，  
为了避免危险，必须由制造商、其维修部或类似部门的专业人员更换。
9. 使用非本产品制造商推荐的配套附件有可能造成危害。
10. 请勿在室外使用。
11. 请勿将电源线缆悬挂在桌子或柜台边缘，或接触包括炉子在内的热表面。
12. 请勿将设备放置于热燃气、电炉、热烤箱之上或附近。
13. 当设备内盛有热油或其他热液体时，在移动设备时更需格外谨慎。
14. 如果要断开慢炖锅电源，请将控制旋钮转至关(OFF)档并将插头从插座中拔出。
15. **注意：**为防止危害或电击，请勿使用基座直接烹饪，仅在可移动内胆内烹饪。
16. 避免突然的温度改变，如将冷冻食物放入已加热的内胆中。
17. 请勿将设备作设计之外功能使用。
18. **小心：**为了避免由于热熔断路器意外重置导致危险，本电器不能在外接定时器或独立的遥控控制系统的方式下运行。

## 请妥善保管说明书！

### 其他用户安全信息

此设备仅供家庭使用。

此设备仅用于食物的准备、烹饪及服务。此设备不能使用非食物类的材料和产品。

此设备使用的电源线缆长度经过设计挑选，以降低线缆缠结或过长导致误绊的危害。如需使用更长的线缆，可使用经过认可的加长线缆。加长线缆的电性能需等同或优于此慢炖锅的电性能。加长线缆需谨慎安置以免其挂于橱面或桌面而因此可能被儿童拉扯或导致误绊。

### 陶制内胆及玻璃盖：预防措施及信息

- 请小心使用内胆和玻璃盖，以保证长使用寿命。
- 避免突然或极端的温度改变。例如，请勿将灼热内胆或玻璃盖置于冷水中，或放置于潮湿的表面上。
- 避免内胆或玻璃盖与水龙头或其他硬表面发生碰撞。
- 如内胆或玻璃盖缺损、开裂或严重刮伤时，请勿使用。
- 请勿使用具有腐蚀作用的清洁剂和金属清洁用品。
- 内胆底部非常粗糙，有可能损坏厨台。请谨慎使用。
- 内胆和玻璃盖在使用时会变得非常灼热，请谨慎使用。请勿将其直接放置于任何未经保护的表面或厨台上。
- 内胆可微波加热且耐热，但请勿空烧。勿将玻璃盖和内胆置于电炉或燃气灶上。请勿将玻璃盖置于微波炉、传统烤箱内或火炉上。

### 移走玻璃盖和内胆

移走玻璃盖时，适度倾斜远离打开锅面以避免蒸汽烫伤。

因加热单元置于慢炖锅底座侧面，此处在使用时会变热。如有必要请使用底座把手。请使用隔热手套移除内胆。



# 部件及特征

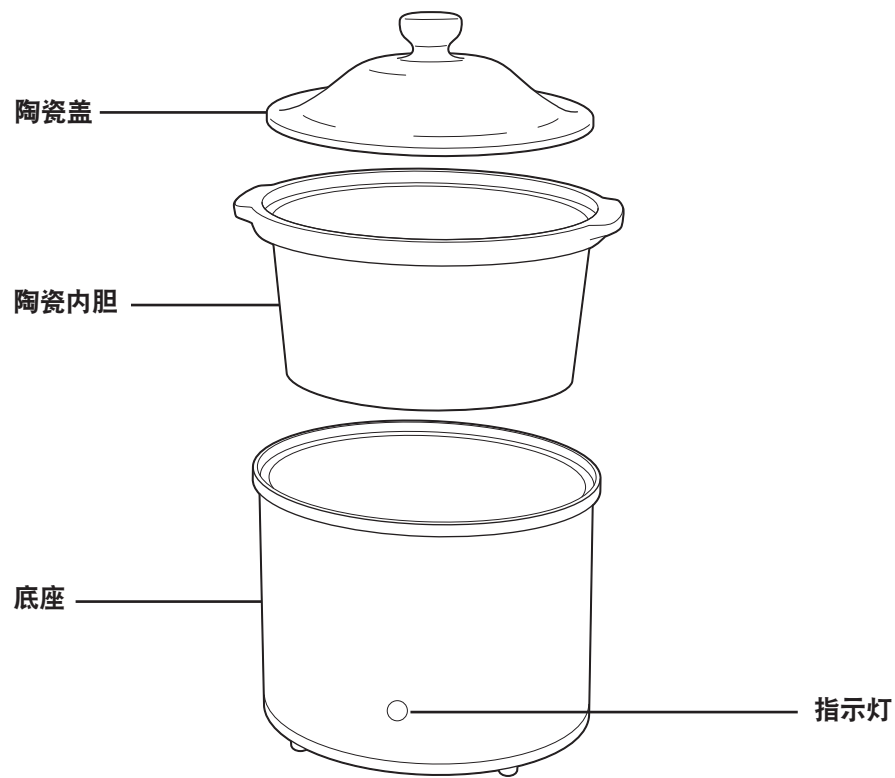

# 如何使用您的慢炖锅

**第一次使用前：** 请用带清洁剂的温水清洗内胆，清洗后弄干。

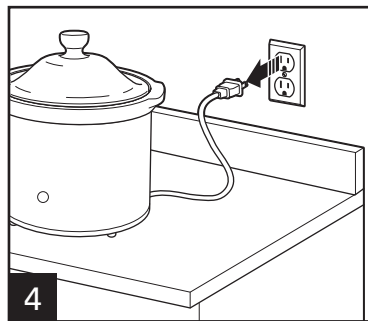
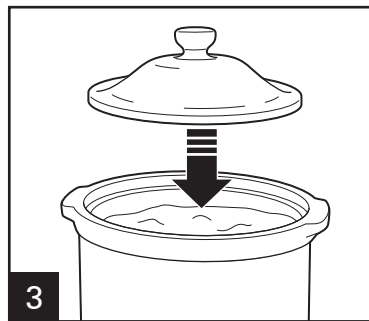
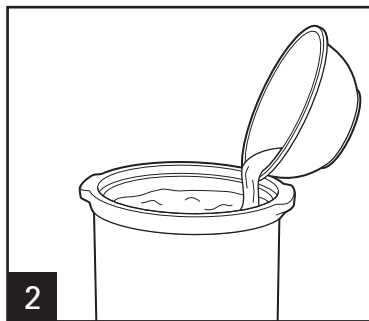
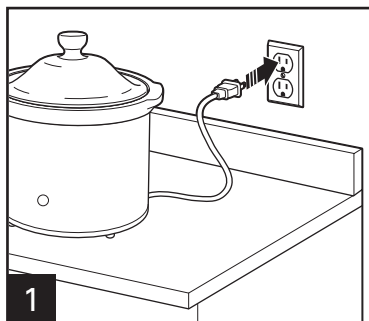

烹饪结束后，请将电源插头拔出插座。清洗前让内胆和锅盖慢慢冷却。

## 慢炖贴士

- 内胆中至少要装满一半食物方能达到最佳烹饪效果。当内胆中只装满一半时，请按照食谱时间提前1至2小时检查食物煮熟程度。
- 慢炖食物时不需要搅拌，打开玻璃盖会造成大量热量损失，因此可能会导致烹饪时间加长。
- 在烹饪汤或者炖菜时，请在内胆顶部与食材之间留出5厘米的空间以能够徐沸食材。
- 许多食谱需要烹饪一整天。如果你早上无暇准备食谱，可在前夜准备。将所有食材放入内胆盖上盖子整夜冷藏，第二天早上只需将内胆放入慢炖锅中烹饪即可。
- 有些食物不适宜在慢炖锅中长时间烹饪。意大利面、海鲜、牛奶、奶油或者酸奶油应在上菜前2小时加入慢炖锅。脱水牛奶或者浓缩汤最适合慢炖锅烹饪。
- 肉类的脂肪含量越高，慢炖时需要的水越少。若慢炖的肉脂肪含量很高，可在底部放些厚洋葱片，这样可防止油煎。
- 慢炖锅基本没有蒸发效果。若烹饪汤、炖菜或酱类食物，可根据原始食谱规定的液量稍作减少。若液量较大，可稍后添加。
- 若烹饪蔬菜类砂锅，食谱中应包含液体以避免内胆侧烧焦食材。
- 若食材内包含根茎类蔬菜，请将其放在内胆底部。

# 妥善放置及清理

## 警告

电击危险。

在清理前请断开电源。请勿将电源线、插头或底座浸入任何液体中。

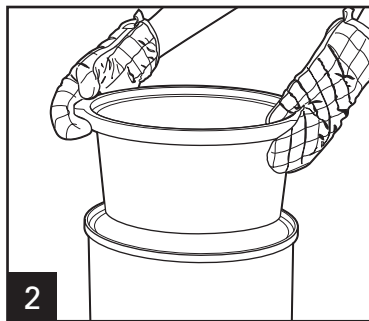
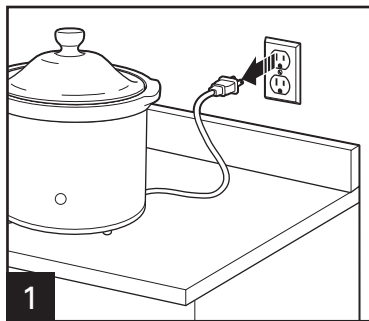

取出内胆并让其自然冷却。

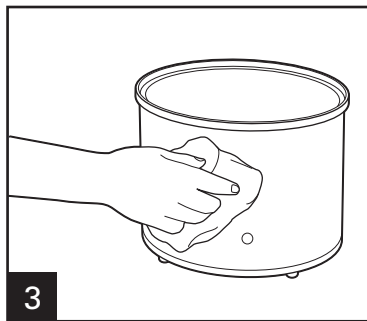

在洗碗机中清洗内胆时，请勿使用消毒档，此档位的循环温度可能会损坏本产品。

注意

注意

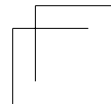
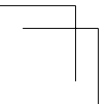
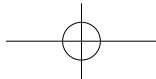
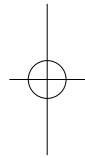
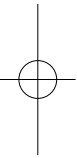
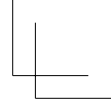
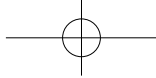

## 食品接触材料信息



本产品符合相应食品安全国家标准要求，食品接触用材料及其执行标准的符合性信息说明如下：

序号	部件名称	材质	执行标准	备注
1.	玻璃盖塑胶垫片	聚丙烯(PP)	GB4806.1-2016;GB4806.7-2016	*
2.	玻璃盖铁氟龙垫片	聚四氟乙烯(PTFE)	GB4806.1-2016;GB4806.7-2016	*
3.	玻璃盖密封硅胶圈	聚二甲基硅氧烷(硅橡胶)	GB4806.1-2016;GB4806.11-2016	*
4.	玻璃盖透气孔垫	聚二甲基硅氧烷(硅橡胶)	GB4806.1-2016;GB4806.11-2016	*
5.	玻璃盖不锈钢大圆头螺钉	不锈钢 06Cr18Ni11Ti (SUS321)	GB4806.1-2016;GB4806.9-2016	*
6.	玻璃盖不锈钢通孔铆钉	不锈钢 06Cr19Ni10 (SUS304)	GB4806.1-2016;GB4806.9-2016	*
7.	玻璃盖不锈钢垫片	不锈钢 06Cr19Ni10 (SUS304)	GB4806.1-2016;GB4806.9-2016	*
8.	玻璃盖不锈钢包边	不锈钢 06Cr19Ni10 (SUS304)	GB4806.1-2016;GB4806.9-2016	*
9.	玻璃盖	玻璃	GB4806.1-2016;GB4806.5-2016	*
11.	黑色陶瓷胆/陶瓷盖	陶瓷	GB4806.1-2016;GB4806.4-2016	*
12.	白色陶瓷胆	陶瓷	GB4806.1-2016;GB4806.4-2016	*

注：1. 特殊使用说明：请严格遵照说明书及产品所带附件资料使用本产品。

2. \* 表示：该部件仅适用于部分型号，具体以实际产品为准。

# 产品保修卡

产品名称: 慢炖锅  
产品类别: SC51  
产品型号: \_\_\_\_\_  
购买日期: \_\_\_\_\_  
购买商店: \_\_\_\_\_  
经销商: \_\_\_\_\_

## 保修规定

- 自购买之日起, 在本保修规定的两年保修期内, 按照使用说明及其它注意事项使用的情况下, 出现故障时, 依照保修规定可持商品及商品发票和保修卡到当地维修站, 进行免费维修或者免费更换。
  - 因使用上的错误和擅自改动、修理而产生的故障及损伤。
  - 购买后因跌落、搬运不当等而产生的故障及损伤。
- 如在保修期内出现以下情况时, 不享受免费维修, 修理费或更换费自付。
  - 因火灾、地震、水灾、打雷、其它天灾人祸及公害、异常电压、其它外部因素而产生的故障及损伤。
  - 属于家庭正常使用以外而出现的故障及损伤。
  - 不出示本保修卡的。
  - 本保修卡只在中国大陆有效。
  - 本保修卡不再发行, 请妥善保管。
  - 在不能携带本产品进行修理的情况下, 请向本公司维修站询问。

## 维修记录

维修日期	维修内容	维修结果	维修地点	维修人签字

中国大陆客服热线:

400-852-2655

官方网站: [www.hamiltonbeach.cn](http://www.hamiltonbeach.cn)

制造商: 汉密尔顿海滩电器(深圳)有限公司

地址: 深圳市福田区深南西路车公庙工业区天安数码

时代大厦主楼1306-1308、1309-1311单元

**Model/型号:**  
**C33101**

**Type/类别:**  
**SC51**

**Capacity/容积:**  
**0.5升**

**Rating/规格:**  
**220V~ 50Hz 50W**

制造商：汉密尔顿海滩电器（深圳）有限公司  
地址：深圳市福田区深南西路车公庙工业区天安数码时代大厦主楼 1306-1308、1309-1311 单元  
本产品执行标准：GB4706.1-2005, GB4706.19-2008

以上内容如有改动，恕不预先通知



添加官方微博 微信  
开启美食人生

840227703