

READ BEFORE USE

Visit www.hamiltonbeach.in for our complete line of products and Use and Care Guides – as well as delicious recipes and tips!

Questions?
Please call us for Express Service – our friendly associates are ready to help.
1.800.42.555.43

Hamilton Beach[®]

Oven Toaster Grill With Rotisserie

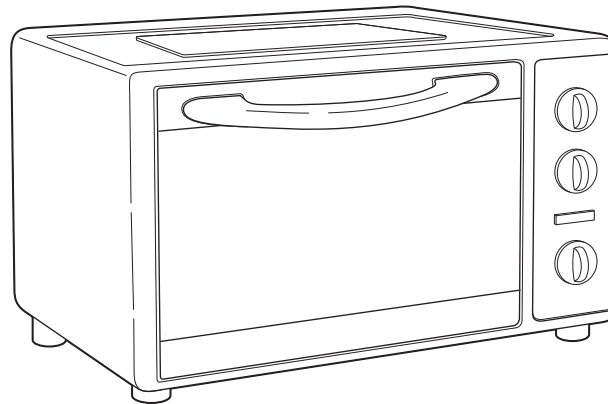

WARNING



Fire Hazard.

- If contents ignite, do not open oven door. Unplug oven and allow contents to stop burning and cool before opening door.
- Do not operate unattended while in Toast or Broil mode.
- Do not use with oven cooking bags.
- Always allow at least one inch between food and heating element.
- Always unplug toaster oven when not in use.
- Regular cleaning reduces risk of fire hazard.

IMPORTANT SAFEGUARDS

This appliance is intended for household use only.

When using electrical appliances, basic safety precautions should always be followed to reduce the risk of fire, electric shock, and/or injury to persons, including the following:

1. Read all instructions.
2. This appliance is not intended for use by persons (including children) with reduced physical, sensory, or mental capabilities, or lack of experience and knowledge, unless they are given supervision and instruction concerning use of the appliance by a person responsible for their safety. Children should be supervised to ensure that they do not play with the appliance.
3. This appliance is intended to be used in household and similar applications such as: staff kitchen areas in shops, offices, and other working environments; farm houses; by clients in hotels, motels, and other residential type environments; bed and breakfast-type environments.
4. Do not touch hot surfaces. Use handles or knobs. Care must be taken, as burns can occur from touching hot parts or from spilled, hot liquid.
5. To protect against electrical shock, do not place cord, plug, or toaster oven in water or other liquid.
6. Unplug from outlet when not in use and before cleaning. Allow to cool before putting on or taking off parts and before cleaning the appliance.
7. Do not operate any appliance with a damaged supply cord or plug, or after the appliance malfunctions or has been dropped or damaged in any manner. Supply cord replacement and repairs must be conducted by the manufacturer, its service agent, or similarly qualified persons in order to avoid a hazard. Call the provided customer service number for information on examination, repair, or adjustment.
8. The use of accessory attachments not recommended by the appliance manufacturer may cause injuries.
9. Do not use outdoors.
10. Do not let cord hang over edge of table or counter or touch hot surfaces, including stove.
11. Do not place toaster oven on or near a hot gas or electric burner or in a heated oven.
12. To disconnect toaster oven, turn controls to OFF and then remove plug from wall outlet.

13. Use extreme caution when removing pan or disposing of hot grease.
14. Do not clean with metal scouring pads. Pieces can break off the pad and touch electrical parts, creating a risk of electrical shock.
15. Oversize foods or metal utensils must not be inserted in a toaster oven as they may create a fire or risk of electric shock.
16. A fire may occur if the toaster oven is covered, touching, or near flammable material, including curtains, draperies, walls, and the like, when in operation. Do not store any item on top of the appliance when in operation or before the appliance cools down.
17. The bread may burn; therefore, do not use near or below combustible material, such as curtains.
18. Extreme caution should be exercised when using containers constructed of materials other than metal or glass.
19. Do not store any materials, other than manufacturer-recommended accessories, in this oven when not in use.
20. Do not place any of the following materials in the oven: paper, cardboard, plastic, and the like.
21. Do not cover crumb tray or any part of the oven with metal foil. This will cause overheating of the oven.
22. To turn oven off, turn timer to OFF (O) position. See "Parts and Features" section.
23. Do not place eyes or face in close proximity with tempered safety glass door, in the event that the safety glass breaks.
24. Always use appliance with crumb tray securely in place.
25. Do not use appliance for other than intended use.
26. Clean oven interior carefully. Do not scratch or damage heating element tube.
27. **CAUTION!** In order to avoid a hazard due to inadvertent resetting of the thermal cut-out, this appliance must not be supplied through an external switching device, such as a timer, or connected to a circuit that is regularly switched on and off by the utility.

SAVE THESE INSTRUCTIONS!

Other Consumer Safety Information

This appliance is equipped with a fully tempered safety glass door. The tempered glass is four times stronger than ordinary glass and more resistant to breakage. Tempered glass can break; however, it breaks into pieces with no sharp edges. Care must be taken to avoid scratching door surface or nicking edges. If the door has a scratch or nick, call our toll-free customer service number.

Always unplug your toaster oven from the outlet when not in use.

BEFORE FIRST USE

Most heating appliances produce an odor and/or smoke when used the first time. Plug the toaster oven into an outlet. Turn Temperature Dial to 240°C. Heat at this temperature for 10 minutes. The odor should not be present after this initial preheating. **Wash skewers, baking pan, and oven rack before using.**

Parts and Features

BEFORE FIRST USE

Most heating appliances produce an odor and/or smoke when used the first time. Plug unit into outlet. Turn FUNCTION dial to BAKE and turn TEMPERATURE dial to 110°C; then rotate TIMER to set for 5 minutes. Let the oven preheat for approximately 5 minutes. The odor should not be present after this initial preheating. **Wash baking pan, broil rack, and oven rack before using.**

 **CAUTION: HOT SURFACE.** The temperature of accessible surfaces may be high when the appliance is operating.

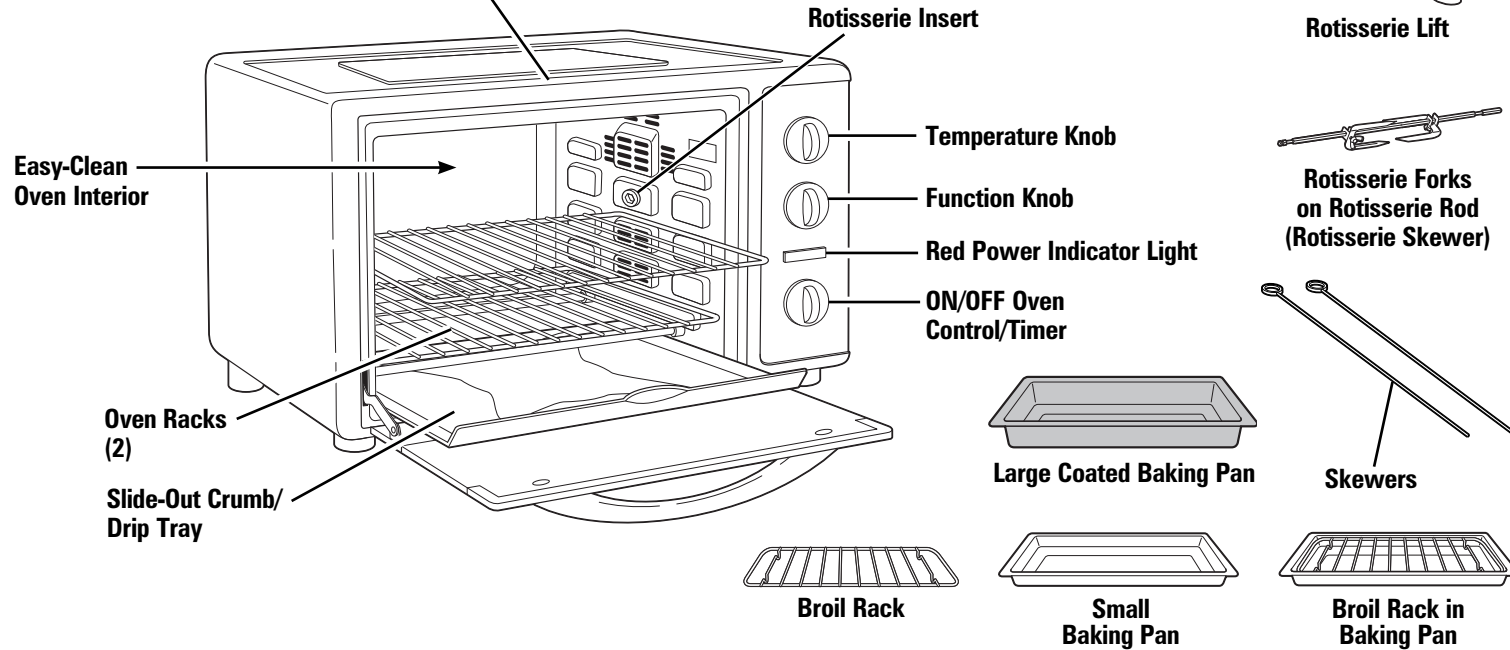

Parts and Features (cont.)

BAKE

Center food in the oven. Rack position will vary depending on size of food.

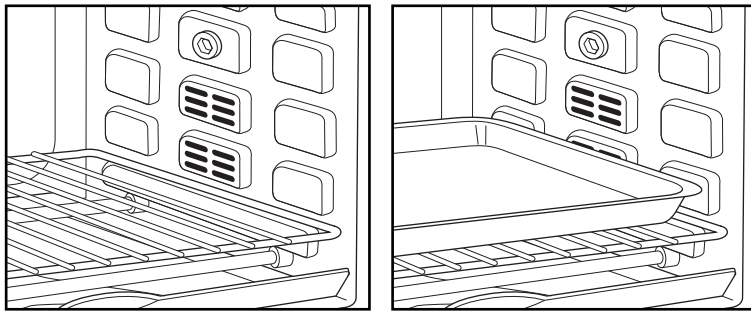

BROIL

Place oven rack in high position.

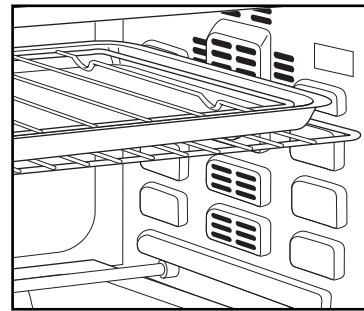

ROTISSERIE

Remove both oven racks.
Place large coated baking pan in the lowest position for drippings.

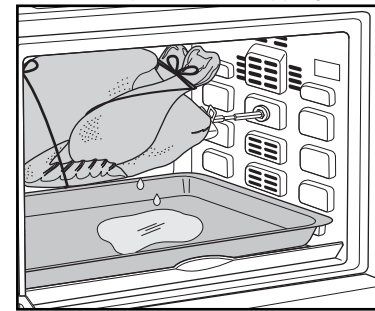

Large Coated Baking Pan

This pan is used instead of an oven rack and is placed in the rack slots.

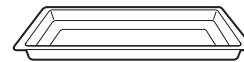

Small Baking Pan

This pan is used on the oven rack.

How to Bake

⚠ WARNING Fire Hazard.

- If contents ignite, do not open oven door. Unplug oven and allow contents to stop burning and cool before opening door.

- Do not use oven cooking bags.
- Always allow at least 2.5 cm between food and heating element.
- Always unplug oven when not in use.

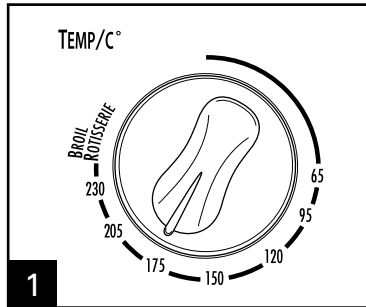

1
Set **TEMPERATURE**:
Rotate Temp Dial to desired temperature.

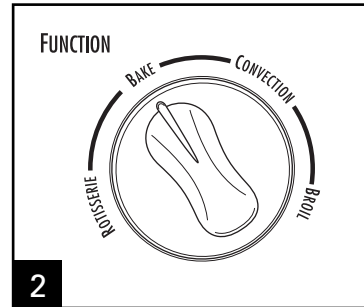

2
Set **FUNCTION** to **BAKE**.

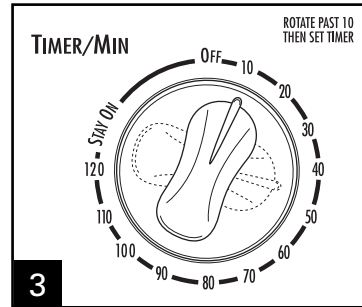

3
PREHEAT:
Rotate Timer past 40, then to 10 minutes to preheat before beginning to bake.

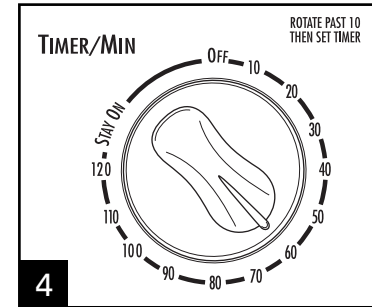

4
BAKE:
After oven is preheated, rotate Timer past 40 minutes and then to desired baking time or rotate Timer to **STAY ON**.

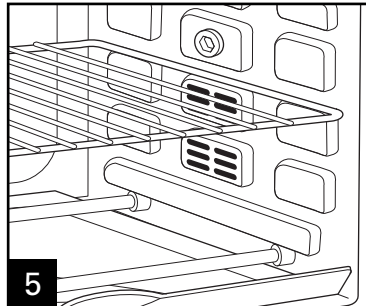

5
Center food in the oven. Rack position will vary depending on size of food.

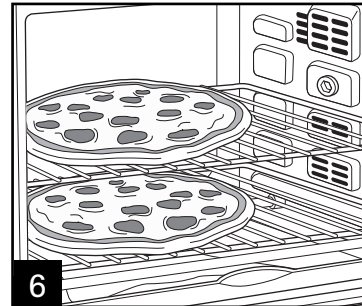
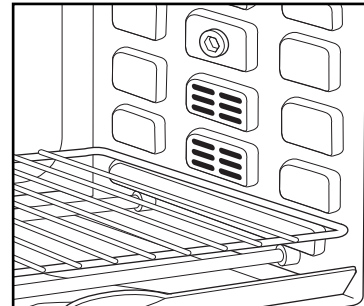

FOR 2 PIZZAS:

Place the baking racks in the bottom rack slot and in the third rack slot (from the bottom). Preheat the oven, and then place the pizzas on the baking racks. Cook the pizzas for about one-half the recommended time, and then switch the baking rack positions to allow the pizzas to be uniformly cooked top and bottom.

How to Bake (cont.)

- Do not totally enclose foods in aluminum foil. Foil can insulate foods and slow down heating.
- Bake foods, such as a whole chicken, on the **LOW RACK POSITION**. Place food in baking pan.
- Ovens with convection mode: When baking pizza, use convection setting and reduce cooking time by 25%.

FOOD	APPROX. BAKE TIMES	INTERNAL TEMPERATURES	
		F	C
Fresh Chicken Breast	30 minutes	170°	77°
Fish Fillet	15 minutes	145°	63°

Turn foods halfway through cooking time.

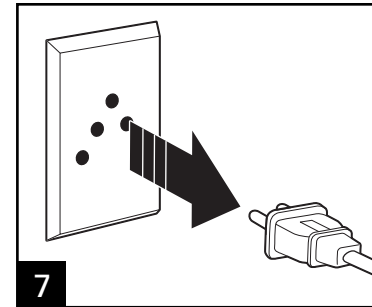

Convection Bake

⚠ WARNING Fire Hazard.

- If contents ignite, do not open oven door. Unplug oven and allow contents to stop burning and cool before opening door.

- Do not use oven cooking bags.
- Always allow at least 2.5 cm between food and heating element.
- Always unplug oven when not in use.

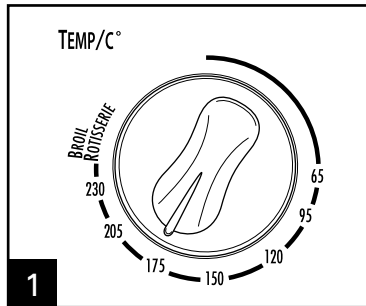

1
Set **TEMPERATURE**:
Rotate Temp Dial to desired temperature.

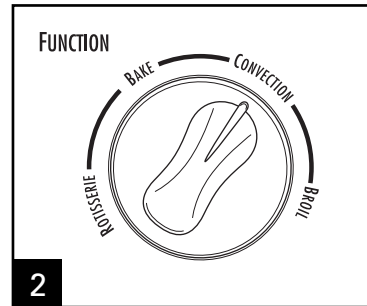

2
Set **FUNCTION** to **CONVECTION**.

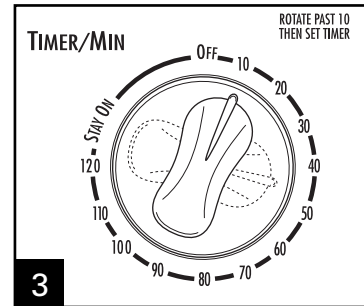

3
PREHEAT:
Rotate Timer past 40, then to 10 minutes to preheat before beginning to bake.

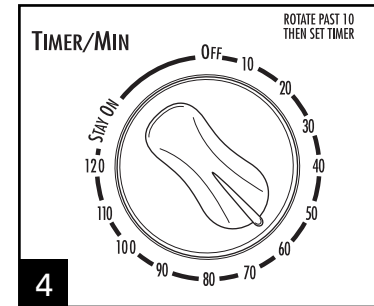

4
BAKE:
After oven is preheated, rotate Timer past 40 minutes and then to desired baking time or rotate Timer to **STAY ON**.

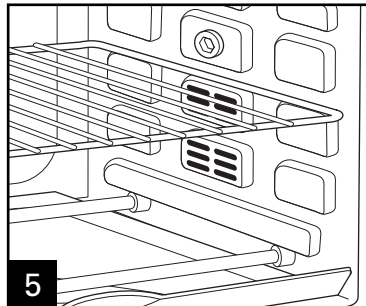

5
Center food in the oven. Rack position will vary depending on size of food.

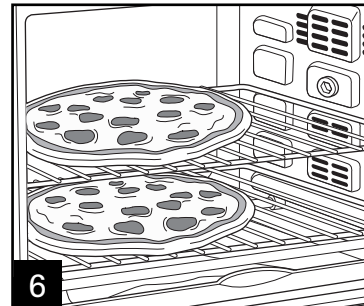
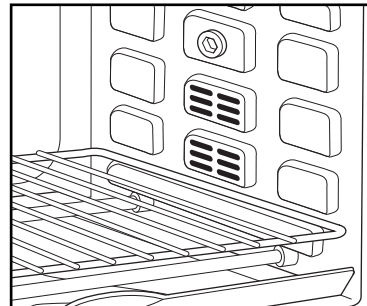

FOR 2 PIZZAS:

Place the baking racks in the bottom rack slot and in the third rack slot (from the bottom). Preheat the oven, and then place the pizzas on the baking racks. Cook the pizzas for about one-half the recommended time, and then switch the baking rack positions to allow the pizzas to be uniformly cooked top and bottom.

Convection Bake (cont.)

TIPS FOR USING CONVECTION BAKE

NOTE: Convection Bake forces more air to circulate in the oven, so food will cook faster than the conventional Bake setting.

- Ovens with convection mode: When baking pizza, use convection setting and reduce cooking time by 25%.

- Bake at the same oven temperature but for a shorter period of time.

OR

- Bake for the same length of time as the conventional Bake setting, but reduce the temperature by about 14 degrees.

OR

- Bake for a slightly shorter period of time AND at a reduced temperature.

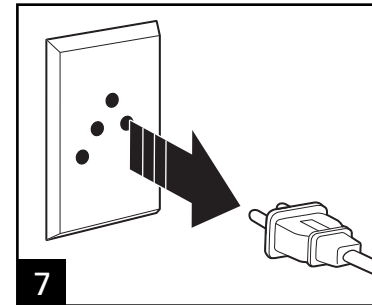

How to Broil

⚠ WARNING Fire Hazard.

- If contents ignite, do not open oven door. Unplug oven and allow contents to stop burning and cool before opening door.
- Do not leave oven unattended during operation.

- Keep 2.5 cm between food and heating element.
- Do not use oven cooking bags.
- Do not heat foods in plastic containers.
- Follow food manufacturer's instructions.

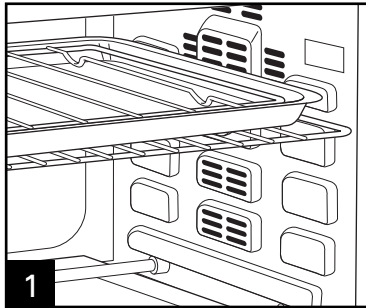

1

Use small baking pan for best results. Place food directly on small baking pan or on broil rack inserted into small baking pan. Place in oven. **DO NOT PREHEAT OVEN.**

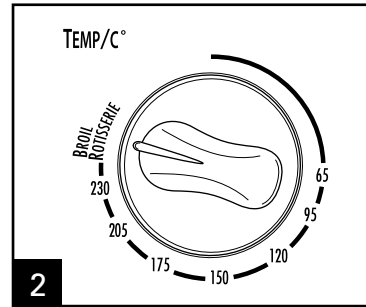

2

Set **TEMPERATURE**: Rotate Temp Dial to **BROIL/ROTISSERIE**.

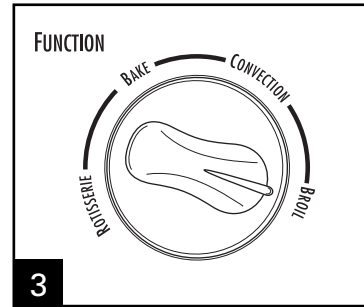

3

Set **FUNCTION** to **BROIL**.
NOTE: Only upper heating elements will be on in **BROIL** mode.

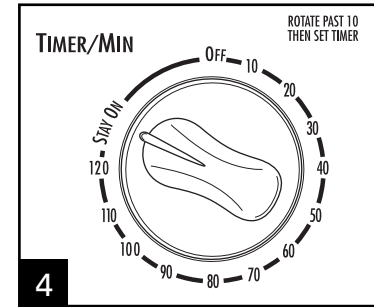

4

BROIL: Rotate Timer past 40 and then to the desired broiling time or rotate Timer to **STAY ON**. Turn foods when browned or halfway through cooking time.

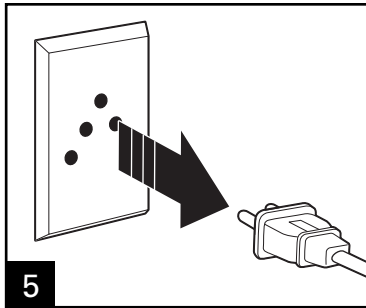

5

Turn foods halfway through cooking time.

Rotisserie Cooking

⚠ WARNING Fire Hazard.

- If contents ignite, do not open oven door. Unplug oven and allow contents to stop burning and cool before opening door.

- Do not use oven cooking bags.
- Always allow at least 2.5 cm between food and heating element.
- Always unplug oven when not in use.

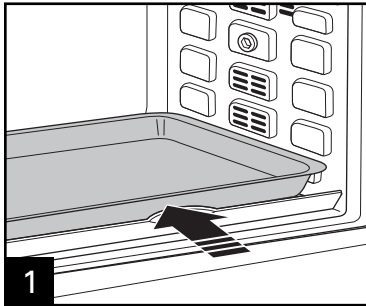

1 Slide large coated baking pan in lowest rack position.

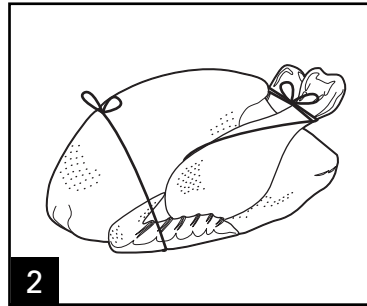

2 Tie chicken and large pieces of meat tightly with cotton string to prevent meat from hitting baking pan. Search "How to Truss a Chicken for Rotisserie" on the Internet for instructions.

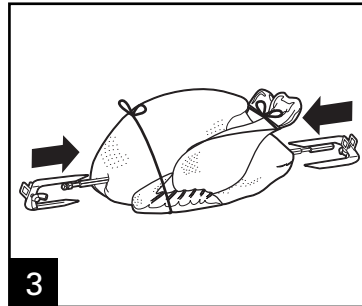

3 Insert rotisserie rod into center of meat.

Place rotisserie forks on rod with forks inserted into the bottom side of the chicken. Center meat lengthwise on rod.

Tighten the screws on the rotisserie forks.

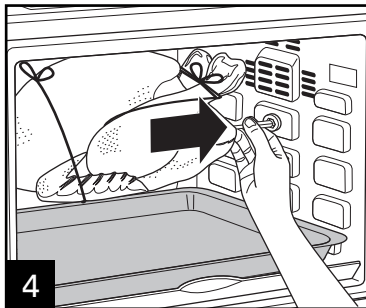

4 Manually insert the pointed end of rod into the rotisserie insert on the right side of the oven, rotating rod if necessary to fit. Place square end of rod into slot in bracket on left side.

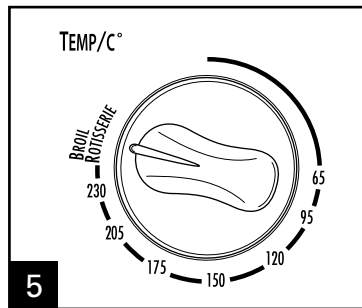

5 Set TEMPERATURE: Rotate Temp Dial to **BROIL/ROTISSERIE**.

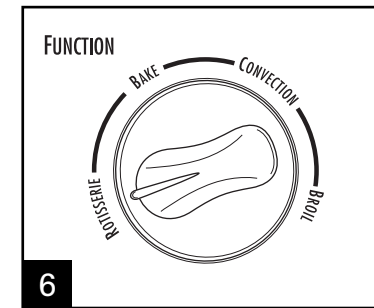

6 Set FUNCTION to **ROTISSERIE**.

Rotisserie Cooking (cont.)

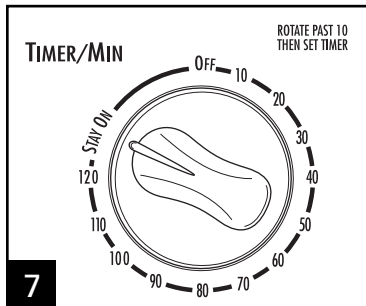

BAKE:
Rotate Timer past 40 minutes;
then set Timer to desired time
or rotate Timer to **STAY ON**.

NOTE: Only upper heating elements
are on in **ROTISSERIE** mode.

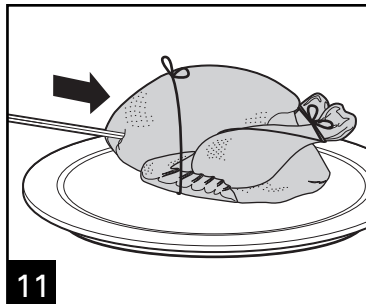

Slide meat onto a serving tray or cutting surface.
Remove rotisserie rod and ties before carving.

12

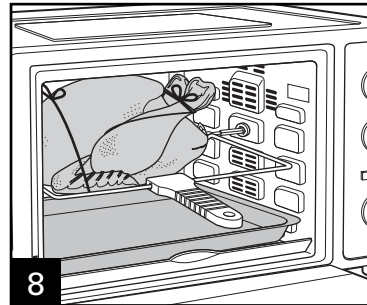

To remove cooked meat from
oven, place the rotisserie lift with
the hooks under the rotisserie rod.
Lift and slide the rotisserie rod
to the left and remove from the
oven.

CAUTION Burn Hazard:
Avoid contact with interior of
oven.

A 2.25 kg chicken should
be cooked to an internal
temperature of 73°C
(approximately 2 hours).

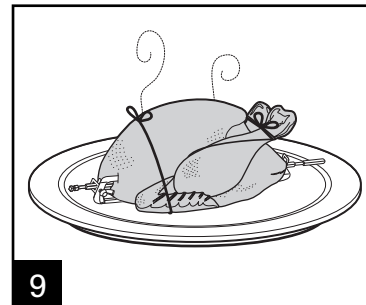

Place meat on a clean surface to
cool slightly.

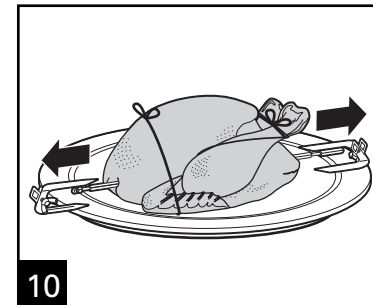

Using oven mitts, unscrew
the rotisserie forks from the
rotisserie rod.

Cleaning

⚠ WARNING Electrical Shock Hazard.

Do not clean with metal scouring pads. Pieces can break off pad and touch electrical parts.

Your oven should be cleaned regularly for best performance and long life. Regular cleaning will also reduce the risk of fire hazard.

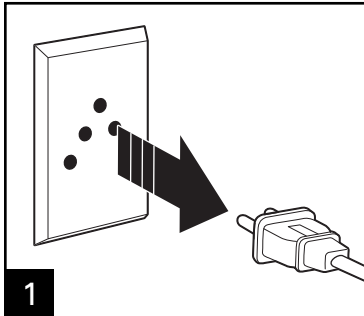

Unplug and allow oven to cool before cleaning.

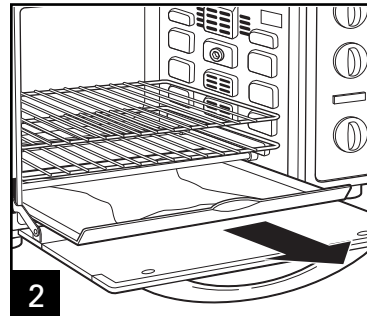

To clean inside of oven, wipe oven walls, bottom of oven, and glass door with a damp, soapy cloth. Repeat with a damp, clean cloth. For stubborn stains, use a plastic scouring pad.

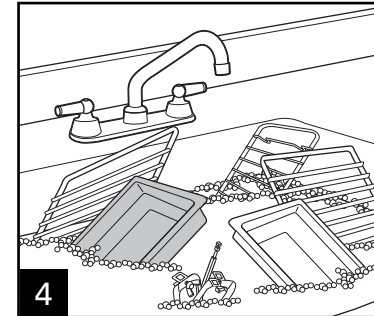
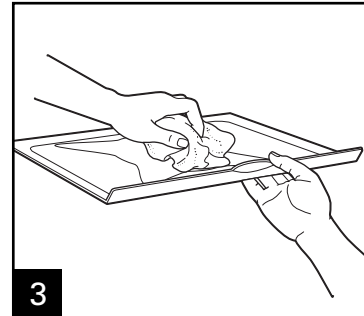

Hand washing and drying will prolong the life of your oven parts.

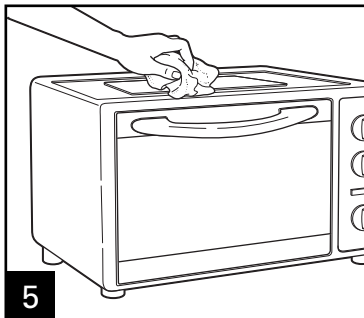

Wipe outside of oven with a damp cloth. Do not use abrasive cleansers or metal scouring pads.

Tips and Troubleshooting

Tips

- When using the black ceramic-coated baking pan, temperature should be set 14 degrees lower than recipe directions.
- Never place glass baking pans or casserole dishes in a countertop oven or toaster oven. Check pan manufacturer's directions for oven-safe rating.
- Do not cover crumb tray or any part of the oven with metal foil. This will cause overheating of the oven. Use of metal foil to cover a casserole during cooking is acceptable.

Troubleshooting

PROBLEM	PROBABLE CAUSE/SOLUTION
Oven will not heat.	<ul style="list-style-type: none">• Check to make sure electrical outlet is working and the oven is plugged in. Turn Temperature Dial to 175°C. Turn Function Dial to BAKE; then turn Timer to STAY ON.
An odor and smoke come from oven.	<ul style="list-style-type: none">• Smoke and odor are normal during first use of most heating appliances. These will not be present after initial heating period.
Some foods burn and some are not done.	<ul style="list-style-type: none">• Adjust oven rack position to center food in oven.• Adjust oven temperature or cooking time for best results with your recipes.
Baking pan does not fit on rack.	<ul style="list-style-type: none">• The large black ceramic-coated baking pan fits directly into slots. Do not use for broiling.• Use the small baking pan and broil rack for broiling.• Refer to Parts and Features for details on baking pans and rack positions.

Notes

Limited Warranty

CUSTOMER NAME: _____
ADDRESS: _____
PHONE NUMBER: _____
MODEL NUMBER: _____
DATE OF PURCHASE: _____ BILL NUMBER: _____

NAME OF DEALER: _____
DEALER'S SIGNATURE: _____
CUSTOMER'S SIGNATURE: _____
STAMP:

SERIAL NUMBER:

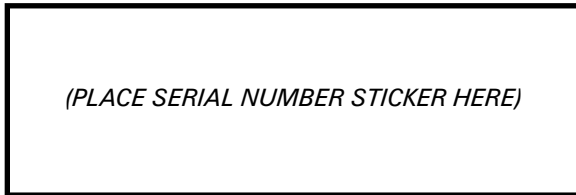

EXPIRY DATE:

SHOULD ANY DEFECT IN MATERIAL OR WORKMANSHIP DEVELOP IN THE PRODUCT,

- CALL 1.800.42.555.43 OR VISIT www.hamiltonbeach.in FOR SERVICE CENTER LOCATIONS OR
- KINDLY TAKE THE PRODUCT TO THE PLACE OF PURCHASE OR
- CALL 1.800.42.555.43 FOR SERVICE AT HOME¹

THE PRODUCT OR ANY COMPONENT OF PRODUCT FOUND TO BE DEFECTIVE WILL BE REPAIRED OR REPLACED FREE OF CHARGE DURING THE WARRANTY PERIOD OF 2 YEARS, FROM THE DATE OF PURCHASE. IF THE PRODUCT OR COMPONENT IS NO LONGER AVAILABLE, WE WILL REPLACE WITH A SIMILAR ONE OF EQUAL OR GREATER VALUE.

¹At-home service is limited to certain geographical areas in India; please call 1.800.42.555.43 for further details.

VALIDITY:

- THIS WARRANTY IS ISSUED SUBJECT TO THE PRODUCTION AND VERIFICATION OF THE ORIGINAL PROOF OF PURCHASE.
- THIS WARRANTY IS VALID IN INDIA ONLY AND IF PRODUCT HAS BEEN PURCHASED FROM AN AUTHORIZED HAMILTON BEACH DEALER.
- THIS WARRANTY DOES NOT COVER GLASS, FILTERS, WEAR FROM NORMAL USE, USE NOT IN CONFORMITY WITH THE PRINTED DIRECTIONS, OR DAMAGE TO THE PRODUCT RESULTING FROM ACCIDENT, ALTERATION, ABUSE, OR MISUSE. THIS WARRANTY ONLY EXTENDS TO THE ORIGINAL CONSUMER PURCHASER OR THE GIFT RECIPIENT.

THE WARRANTY WILL BE CONSIDERED INVALID IF:

- PRODUCT HAS NOT BEEN USED PER THE MANUFACTURER'S OPERATING INSTRUCTIONS.
- PRODUCT HAS BEEN SERVICED, REPAIRED, OPENED, OR TAMPERED WITH BY ANY UNAUTHORIZED PERSON.
- UNAUTHORIZED CORRECTION/ALTERATIONS IN INVOICE COPY/INSTALLATION NOTE/SERIAL NUMBER OF PRODUCT.
- INCOMPLETE WARRANTY CARD AFTER PURCHASE.
- ANY ATTACHMENTS NOT RECOMMENDED BY THE MANUFACTURER HAVE BEEN USED ON THE PRODUCT.
- PRODUCT IS USED FOR OTHER THAN SINGLE-FAMILY HOUSEHOLD USE OR SUBJECTED TO ANY VOLTAGE AND WAVEFORM OTHER THAN 220-240V~/ 50/60 Hz.