

READ BEFORE USE

使用前阅读

Visit www.hamiltonbeach.cn for our complete line of products and Use and Care Guides – as well as delicious recipes, tips, and to register your product online!

有关我们所有系列产品的，使用与维护指南 – 以及美味食谱、生活小贴士和产品在线注册的更多信息，请访问 www.hamiltonbeach.cn。

Questions?

Please call us – our friendly associates are ready to help.
China: 400-852-2655

如有疑问？

请致电我们，我们的团队随时准备为您提供帮助。

中国大陆免费客服热线：
400-852-2655

官方网站：www.hamiltonbeach.cn

型号：31126-CN

此说明书中图片仅供参考，产品以实物为准。

使用本设备前，我们建议您仔细阅读这些说明。

Hamilton 汉美驰 Beach®

Toaster Oven 电烤箱



English 2
简体中文 12

⚠ WARNING



Fire Hazard.

- If contents ignite, do not open oven door. Unplug oven and allow contents to stop burning and cool before opening door.
- Do not operate unattended while in Toast or Broil modes.
- Do not use with oven cooking bags.
- Always allow at least one inch between food and heating element.
- Always unplug toaster oven when not in use.
- Regular cleaning reduces risk of fire hazard.

IMPORTANT SAFEGUARDS

When using electrical appliances, basic safety precautions should always be followed to reduce the risk of fire, electric shock, and/or injury to persons, including the following:

1. Read all instructions.
2. This appliance is not intended for use by persons (including children) with reduced physical, sensory, or mental capabilities, or lack of experience and knowledge, unless they are closely supervised and instructed concerning use of the appliance by a person responsible for their safety.
3. Close supervision is necessary when any appliance is used by or near children. Children should be supervised to ensure that they do not play with the appliance.
4. Do not touch hot surfaces. Use handles or knobs.
5. To protect against electric shock, do not immerse cord, plug, or toaster oven in water or other liquid.
6. Unplug from outlet when not in use and before cleaning. Allow to cool before cleaning appliance and putting on or taking off parts.
7. Do not operate any appliance with a damaged cord or plug, or after the appliance malfunctions or is dropped or damaged in any manner. Call our toll-free customer service number for information on examination, repair, or adjustment. If the supply cord is damaged, it must be replaced by the manufacturer, its service agent or similarly qualified persons in order to avoid a hazard.
8. The use of accessory attachments not recommended by the appliance manufacturer may cause injuries.
9. Do not use outdoors.
10. Do not let cord hang over edge of table or counter or touch hot surfaces.
11. Do not place on or near a hot gas or electric burner or in a heated oven.
12. Extreme caution must be used when moving an appliance containing hot oil or other hot liquids.
13. To disconnect, turn all controls to OFF (O); then remove plug from wall outlet.
14. Use extreme caution when removing pan or disposing of hot grease.

15. Do not clean with metal scouring pads. Pieces can break off the pad and touch electrical parts, creating a risk of electrical shock.
16. Oversize foods or metal utensils must not be inserted in a toaster oven as they may create a fire or risk of electric shock.
17. A fire may occur if the toaster oven is covered, touching, or near flammable material, including curtains, draperies, walls, and the like, when in operation. Do not store any item on top of the appliance when in operation or before the appliance cools down.
18. Extreme caution should be exercised when using containers constructed of materials other than metal or glass.
19. Do not store any materials, other than manufacturer-recommended accessories, in this oven when not in use.
20. Do not place any of the following materials in the oven: paper, cardboard, plastic, and the like.
21. Do not cover crumb tray or any part of the oven with metal foil. This will cause overheating of the oven.
22. To turn oven off, turn timer to OFF (O) position. See "Parts and Features" section.
23. Do not place eyes or face in close proximity with tempered safety glass door, in the event that the safety glass breaks.
24. Always use appliance with crumb tray securely in place.
25. Do not use appliance for other than intended use.
26. Clean oven interior carefully. Do not scratch or damage heating element tube.
27. **CAUTION:** In order to avoid a hazard due to inadvertent resetting of the thermal cut-out, this appliance must not be supplied through an external switching device, such as a timer, or connected to a circuit that is regularly switched on and off by the utility.

SAVE THESE INSTRUCTIONS!

Other Consumer Safety Information

This product is intended for household use only.

The length of the cord used on this appliance was selected to reduce the hazards of becoming tangled in or tripping over a longer cord. If a longer cord is necessary, and approved extension cord may be used. The electrical rating of the extension cord must be equal to or greater than the rating of the appliance. Care must be taken to arrange the extension cord so that it will not drape over the counter-top or tabletop where it can be pulled on by children or accidentally tripped over. To avoid an electrical circuit overload, do not use another high-wattage appliance on the same circuit with this appliance.

This appliance is equipped with a fully tempered safety glass door. The tempered glass is four times stronger than ordinary glass and

more resistant to breakage. Tempered glass can break; however, it breaks into pieces with no sharp edges. Care must be taken to avoid scratching door surface or nicking edges. If the door has a scratch or nick, call our toll-free customer service number.

Always unplug your toaster oven from the outlet when not in use.

BEFORE FIRST USE

Most heating appliances produce an odor and/or smoke when used the first time. Plug the toaster oven into an outlet. Turn Temperature Dial to 450°F (230°C). Heat at this temperature for 10 minutes. The odor should not be present after this initial preheating. **Wash baking pan and oven rack before using.**

Parts and Features

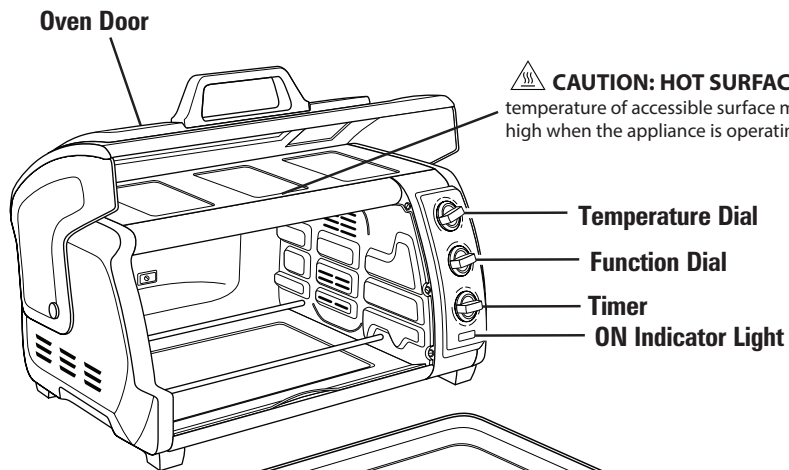

 **CAUTION: HOT SURFACE.** The temperature of accessible surface may be high when the appliance is operating.

HIGH RACK POSITION:
toasting and broiling

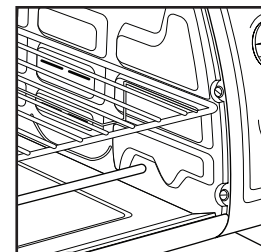

LOW RACK POSITION:
baking

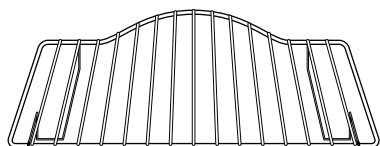
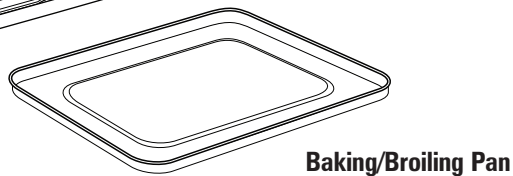
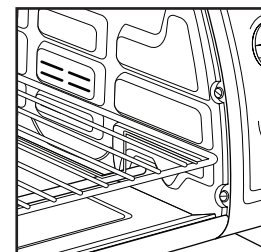

Toasting/Baking/Broiling Oven Rack

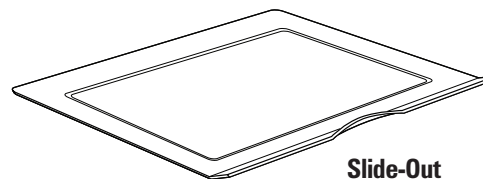

Slide-Out
Crumb Tray

How to Toast

⚠️ **WARNING** Fire Hazard.

- If contents ignite, do not open oven door. Unplug oven and allow contents to stop burning and cool before opening door.

- Do not operate with door open or removed.
- Do not leave appliance unattended when in operation.
- Always unplug toaster oven when not in use.

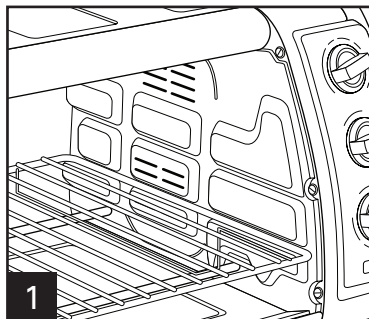

Plug in toaster oven. Place oven rack in **HIGH RACK POSITION** (shown) for toast, English muffins, bagels, and waffles.

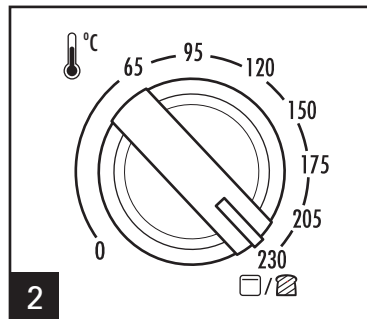

Turn Temperature Dial to maximum temperature. Place food in oven.

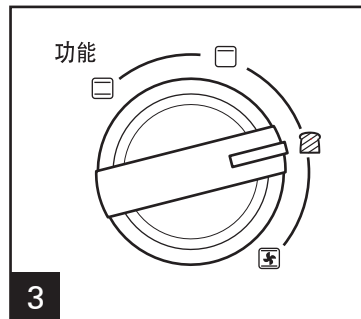

Turn Function Dial to  (**TOAST**).

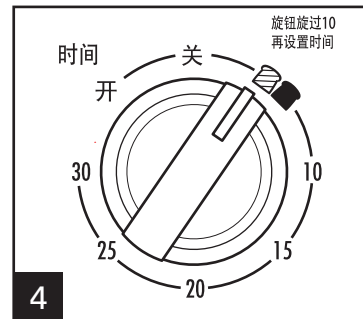

Rotate Timer past 10 and then back to desired toast color. A bell will sound when the toast cycle is complete.

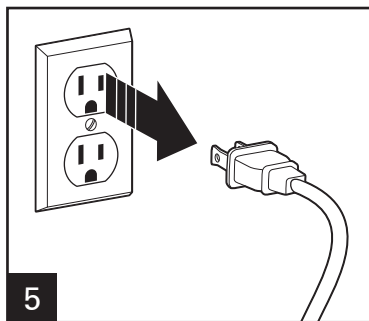

- **When toasting only two slices of bread**, place bread in middle of oven rack to get even toasting on top and bottom.
- **To toast bagels, English muffins, and waffles**, place oven rack in **HIGH RACK POSITION** and place food cut/split side facing up. This will toast the cut/split side more than the outside food. Set Timer to desired setting.
- **To toast regular toaster pastries or frozen pastries**, place oven rack in the **HIGH RACK POSITION**. Select a lighter color and toast directly on the oven rack. If pastry has a glaze or frosting, use baking pan.

- When toasting, **condensation** may form on the oven door. The moisture will slowly escape from the enclosed oven.
- The **number of slices** of bread and the **bread freshness** will affect toast color. For example, toasting 4 slices of bread will require a darker toast color setting than 2 slices of bread. Adjust the Timer based on desired color and number of slices.
- If you are not satisfied with the color balance between the two sides of your food in the recommended rack position, select a different rack position.

How to Bake

⚠️ WARNING Fire Hazard.

- If contents ignite, do not open oven door. Unplug oven and allow contents to stop burning and cool before opening door.
- Do not use oven cooking bags.

- Do not operate with door open or removed.
- Always allow at least 1 inch (2.5 cm) between food and heating element.
- Always unplug toaster oven when not in use.

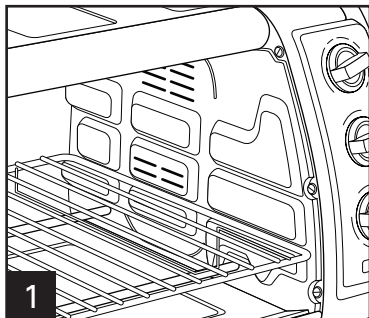

Plug in toaster oven. Place oven rack on **LOW RACK POSITION** (shown).

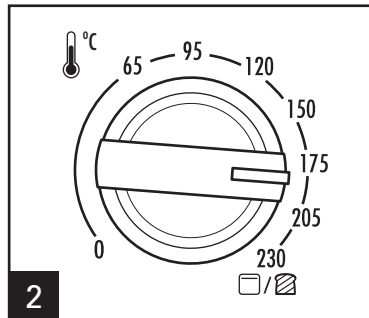

Turn Temperature Dial to desired temperature.

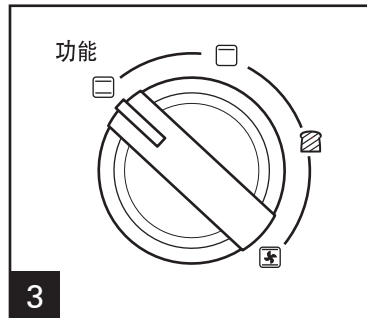

Turn Function Dial to  (**BAKE**).

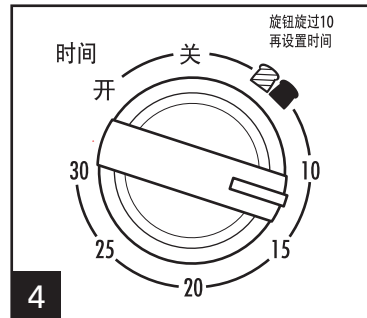

Rotate Timer past 10 and let oven preheat for 5 minutes prior to placing food in oven.

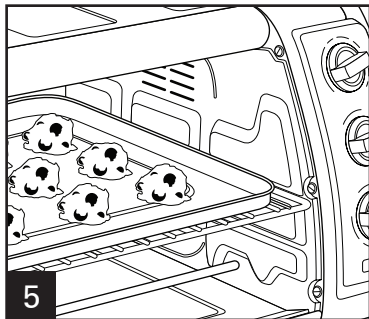

Place the baking pan on oven rack. Set Timer to desired time by rotating Timer past 10 and then to desired baking time or rotate Timer to **STAY ON**.

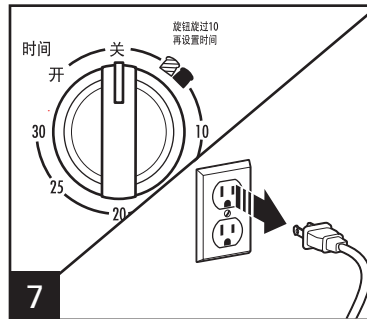
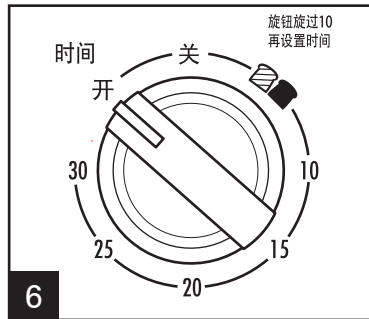

When finished, turn Timer dial to **OFF (O)** and unplug.

How to Bake (cont.)

- Do not totally enclose foods in aluminum foil. Foil can insulate foods and slow down heating.
- To reheat rolls or biscuits, place on baking pan and heat at 300°F (149°C) for 10 minutes.
- Reheat leftover roasts or casseroles at 350°F (177°C) for 20 to 30 minutes or until heated through.
- Bake foods, such as pizza, on the **LOW RACK POSITION**. Place food directly on oven rack or in baking pan.
- Bake foods, such as a whole chicken, on the **LOW RACK POSITION**. Place food in baking pan.
- Convection mode: When baking pizza, use convection setting and reduce cooking time by 25%.
- Turn foods halfway through cooking time.

Convection Bake

⚠️ **WARNING** Fire Hazard.

- If contents ignite, do not open oven door. Unplug oven and allow contents to stop burning and cool before opening door.

- Do not use oven cooking bags.
- Always allow at least 1 inch (2.5 cm) between food and heating element.
- Always unplug toaster oven when not in use.

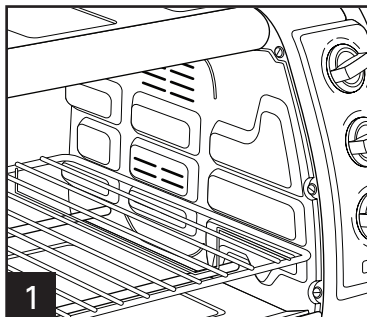

Plug in toaster oven. Place oven rack on **LOW RACK POSITION**. Turn Temperature Dial to desired temperature.

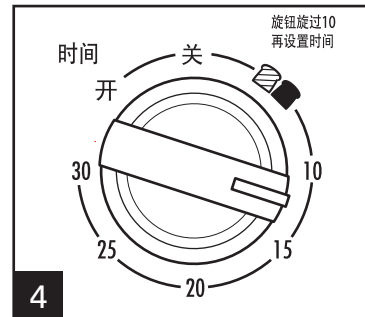
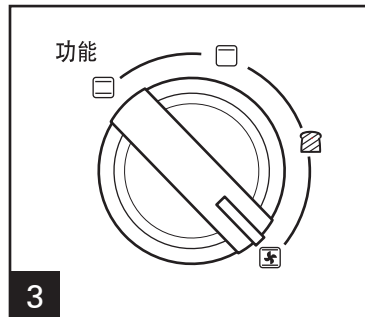
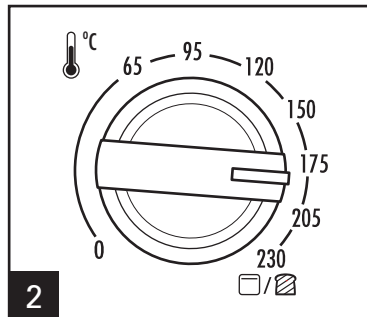

Turn Function Dial to **CONVECTION**. Rotate Timer past 10 and then let oven preheat for 5 minutes before beginning to bake. After oven is preheated, set Timer to desired time by rotating Timer past 10 and then to desired baking time or rotate Timer to **STAY ON**.

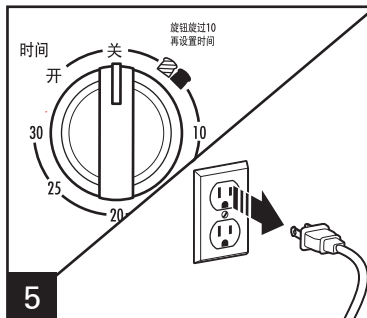

When finished, turn Timer dial to **OFF (O)** and unplug.

TIPS FOR USING CONVECTION BAKE

NOTE: Convection Bake forces more air to circulate in the oven, so food will cook faster than the conventional **BAKE** setting.

- Bake at the same oven temperature but for a shorter period of time.

OR

- Bake for the same length of time as the conventional **BAKE** setting, but reduce the temperature by about 25 degrees.
- When baking pizza, use convection setting and reduce cooking time by 25%.

How to Broil

⚠ WARNING Fire Hazard.

- If contents ignite, do not open oven door. Unplug oven and allow contents to stop burning and cool before opening door.
- Do not leave oven unattended during operation.

- Do not operate with door open or removed.
- Keep 1 inch (2.5 cm) between food and heating element.
- Do not use oven cooking bags.
- Do not heat foods in plastic containers.
- Follow food manufacturer's instructions.

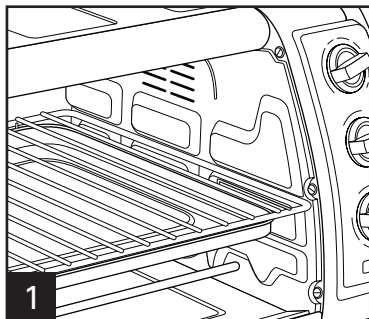

1

Plug in toaster oven. Slide oven rack into **HIGH RACK POSITION**. Insert baking/broiling pan in slots under the oven rack and add food to rack. **DO NOT PREHEAT OVEN.** Turn Temperature Dial to (BROIL/TOAST).

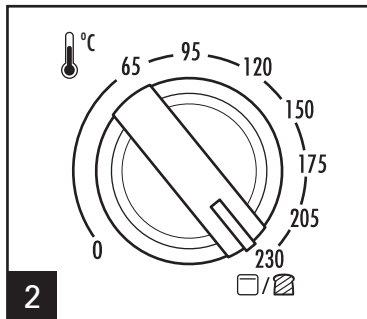

2

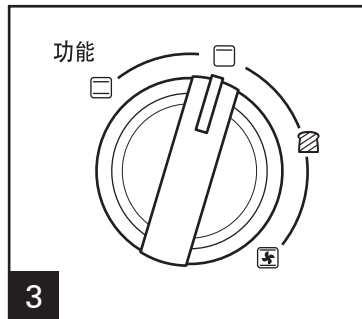

3

Turn Function Dial to (**BROIL**). Rotate Timer past 10 and then to the desired broiling time or rotate Timer to **STAY ON**. Turn foods when browned or halfway through cooking time.

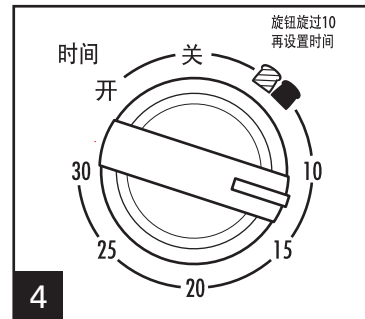

4

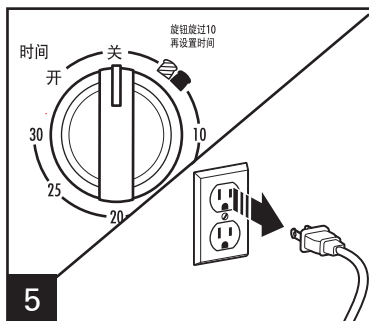

5

When finished, turn Timer dial to **OFF (O)** and unplug.

- Cook beef to at least 145°F (63°C).
- Cook ground meat and pork to at least 160°F (71°C).
- Cook chicken to at least 165°F (73°C).
- Cook fish until at least 145°F (63°C) or until opaque or flakes with a fork.

Care and Cleaning

⚠ WARNING Electrical Shock Hazard.

Do not clean with metal scouring pads. Pieces can break off pad and touch electrical parts.

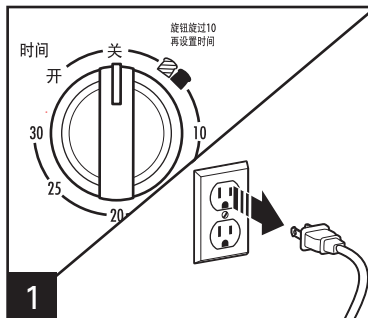

1 When finished, turn Timer dial to **OFF (O)** and unplug.

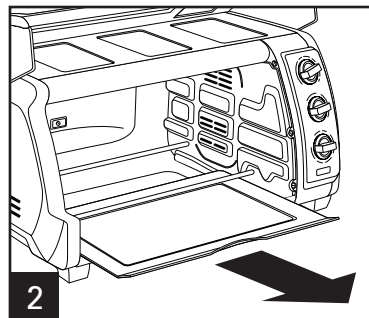

2 To clean inside of oven, wipe oven walls, bottom of oven, and glass door with a damp, soapy cloth. Repeat with a damp, clean cloth. For stubborn stains, use a plastic scouring pad.

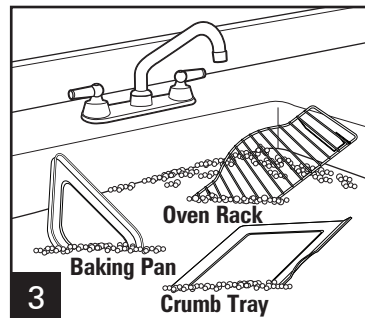

3 Hand wash in warm, soapy water, rinse, and dry.

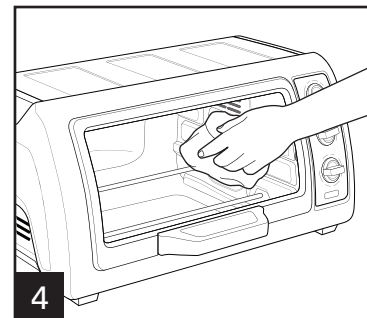

4 Wipe outside of oven with a damp cloth. Do not use abrasive cleansers or metal scouring pads.

Troubleshooting



PROBLEM	PROBABLE CAUSE/SOLUTION
Oven will not heat.	<ul style="list-style-type: none">• Check to make sure electrical outlet is working and the oven is plugged in. Turn Temperature Dial to 350°F (177°C) and turn Timer to STAY ON.
Moisture forms on inside of oven door when toasting.	<ul style="list-style-type: none">• This is normal when toasting in a toaster oven. Moisture is slower to escape from a toaster oven than from a toaster. The amount of moisture will differ between fresh bread, bagels, and frozen pastries.
An odor and smoke come from oven.	<ul style="list-style-type: none">• Smoke and odor are normal during first use of most heating appliances. These will not be present after initial heating period.
Oven will not toast.	<ul style="list-style-type: none">• Check to make sure outlet is working and oven is plugged in. Turn Temperature Dial to ☞ (toast) and rotate Timer past 10 and then back to desired toast color.
Some foods burn and some are not done.	<ul style="list-style-type: none">• Adjust oven temperature or cooking time for best results with your recipes.
Concentrated steam comes out of top corners of oven door.	<ul style="list-style-type: none">• Moisture escaping from oven will be concentrated into streams from the top corners of the door. This gives the appearance of smoke. This is normal for this product.

Visit www.hamiltonbeach.cn for our complete line of products and Use and Care Guides – as well as delicious recipes, tips, and to register your product online!

警告



火灾危险。

- 如果烤箱内物件着火，请勿打开烤箱门。拔下烤箱电源插头，让着火物件停止燃烧并冷却后再打开烤箱门。
- 在 （烤面包）或 （烧烤）模式下，请勿置于无人看管状态。
- 请勿与烤箱蒸煮袋同时使用。
- 务必在食材和加热元件之间保留至少 2.5 厘米间隙。
- 未使用时，务必拔下烤箱电源插头。
- 定期清洁可减少火灾危险。

重要安全说明

当使用电器时，应始终遵守基本的安全防范措施，以减少火灾、触电和/或人身伤害的风险，包括以下内容：

1. 阅读所有相关说明。
2. 本电器不适合以下人群（包括儿童）使用：行动不便者、精神或智商缺陷者、缺少经验和常识者，除非他们在监护人的密切监督和指导下使用，以确保安全。
3. 当电器由儿童使用、或在其附近使用时，应予以密切监督。请勿用于儿童玩耍。
4. 请勿接触设备热表面。应使用手柄或旋钮。
5. 为防止触电，请勿将底座、电源线或插头放入水或其他液体中。
6. 不使用与清洁前，请从插座拔下电源。拆装部件前以及清洁前，必须让电器冷却。
7. 在下列情况下，请勿使用电器：电源线或插头破损、电器出现故障、电器曾跌落或已经出现任何形式的损坏。请拨打我们的免费售后服务电话，咨询有关电器检查、修理或调整的相关信息。如果电源软线损坏，为了避免危险，必须由制造商、其维修部或类似部门的专业人员更换。
8. 使用非本电器制造商推荐的配套附件可能会导致受伤。
9. 请勿户外使用。
10. 请勿将电源线搭置在桌台边缘上以及与发热表面接触。
11. 请勿置于燃气、电炉、热烤箱上面或附近。
12. 当移动含有热油或其他热液体的电器时，应特别小心。
13. 断开电源前，将所有的控制器调整到关位置，然后从电源插座上拔下插头。
14. 取出烤盘或处理热油时，应特别小心。
15. 请勿使用金属清洁球清洁设备。金属清洁球可能会有部分金属脱落，并可能接触到带电部件，有电击的危险。
16. 尺寸过大的食物或金属器具绝对禁止放入烤箱中，可能引起火灾或电击。
17. 在操作时，如果烤箱被覆盖、接触或靠近易燃材料（包括窗帘、布料、墙壁等）时，容易引起火灾。当操作时或电器冷却前，请勿在电器顶部放置任何物品。

18. 当使用非金属或玻璃制容器时应特别小心。
19. 当烤箱不使用时，请勿将任何非制造商推荐的配件存放到烤箱中。
20. 请勿将下列材料放入到烤箱中：纸、纸板、塑料等类似材料。
21. 请勿使用金属箔盖住屑盘或烤箱的任何部件。这将导致烤箱过热。
22. 关闭烤箱时，将定时器旋转到关位置。详见“部件和功能”章节。
23. 请勿让脸部或眼睛靠近钢化安全玻璃门，以防安全玻璃门破裂。
24. 务必将屑盘固定到位。
25. 请勿将本电器用于非预期用途。
26. 小心清洁烤箱内部。请勿刮伤或损坏加热元件管。
27. **小心：**为了避免由于热熔断器意外重置导致危险，本电器不能在外接定时器或独立的遥控控制系统的方式下运行。

请妥善保管这些说明！

其他用户安全信息

本产品建议于家庭使用。

本电器使用的电源线长度经过设计挑选，以降低电源线过长导致缠绕或绊倒的危险。倘若需要更长的电源线，可使用有认证的电源延长线。电源延长线的额定功率必须等于或大于此设备的额定功率。如果该设备配有接地型电源线，电源延长线也必须使用接地型电源线。电源延长线使用时需特别注意，以防将其搭设在工作台或桌面上，造成儿童拉扯或绊倒他人。为防电路过载，请勿在电器的同一个电路上使用其他高功率电器。

本设备装有钢化安全玻璃门。钢化玻璃具有四倍于普通玻璃的强度，更具抗裂性。钢化玻璃会碎裂；但是碎屑尚有锋利边缘。需小心清理，避免刮花玻璃门表面或刮伤玻璃门边缘。如果烤箱门有刮花或刻痕，请拨打我们的免费客服电话。

不使用时，总是从插座上拔下电源插头。

初次使用前

大部分发热类器具在初次使用时会散发异味和/或冒烟。将烤箱插头插入插座。将温控器旋钮旋至 230°C。在此温度下加热 10 分钟。初次加热后，异味消失。**使用前，请清洗烤盘和烤网架。**

部件和功能

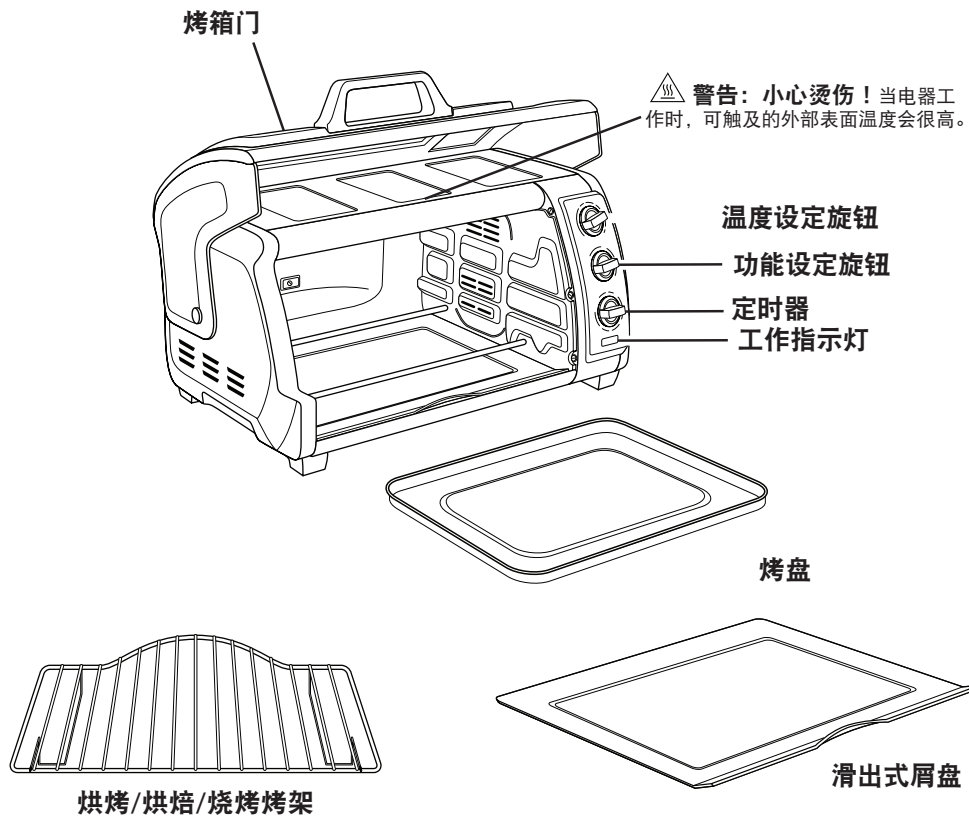

顶层烤架位置：
烘烤和烧烤

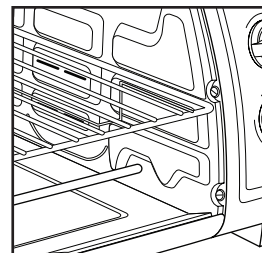

底层烤架位置：
烘烤

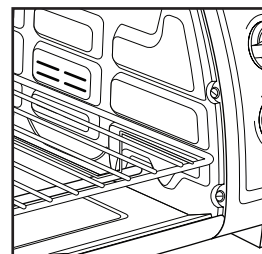

如何烤面包

警告 火灾危险。

- 如果烤箱内物件着火，请勿打开烤箱门。拔下烤箱电源插头，让着火物件停止燃烧并冷却后再打开烤箱门。

- 请勿在玻璃门处于打开或取下状态时操作。
- 请勿让电器在工作期间处于无人看管状态。
- 未使用时，务必拔下烤箱电源插头。

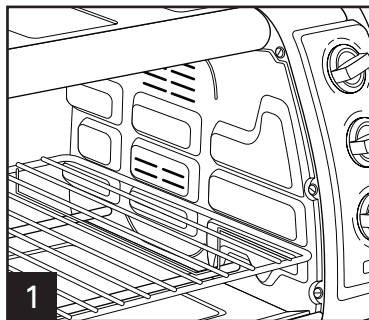

1 插上电源插头，烤土司、英式松饼、百吉饼和华夫饼时，请将烤架置于**顶层烤架位置**（如图所示）。

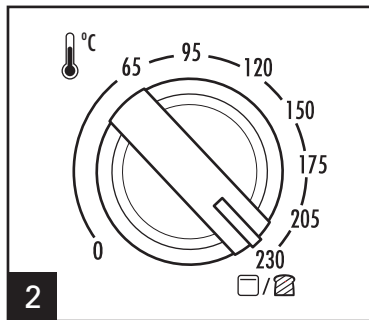

2 将温度设定旋钮旋至最高温度。将食材放入烤箱。

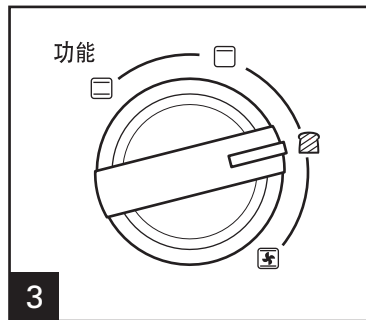

3 将功能旋钮旋至 （烤面包）。

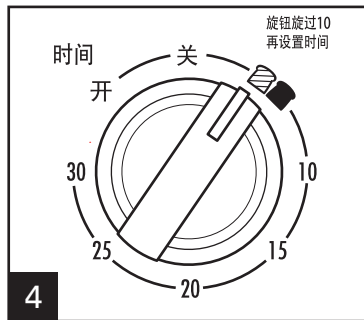

4 将定时器旋钮旋至超过 10 分钟，然后再往回旋至所需烘焙色泽。烘烤完成后，将会发出响铃声。

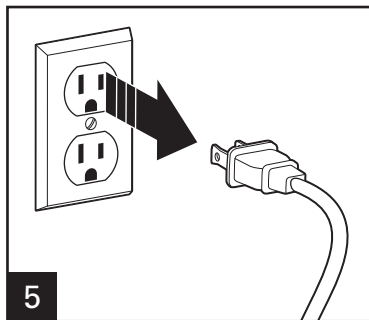

5

- 只烤两片面包时，请将面包放置在烤架中心区，使面包上部和底部均匀烘烤。
- 要烤百吉饼、英式松饼和华夫饼时，请将烤架置于**顶层烤架位置**，并将食材切开的一面朝上放置。这会让食材切开的一面比食材外部烤的更久。按所需设置设定定时器。
- 要烤普通糕点或速冻面点时，请将烤架置于**顶层烤架位置**。选择更浅的色泽，直接放在烤架上烘烤。如果糕点含有糖浆或糖霜，请使用烤盘。
- 烘烤时，烤箱门上可能会**凝结水珠**。水雾将缓慢从密闭烤箱中溢出。
- 切片面包数量和面包新鲜程度将影响烘烤色泽。如，烤 4 片面包比烤 2 片面包需要更深的烘焙色泽设置。根据所需色泽和切片面包数量调整定时器设置。
- 如果您对建议的烤架位置所烘焙食材的两面色泽平衡不满意，请选择不同的烤架位置。

如何烘烤

警告 火灾危险。

- 如果烤箱内物件着火，请勿打开烤箱门。拔下烤箱电源插头，让着火物件停止燃烧并冷却后再打开烤箱门。
- 请勿使用烤箱蒸煮袋。

- 请勿在玻璃门处于打开或取下状态时操作。
- 务必在食材和加热元件之间保留至少 1 英寸 (2.5 厘米) 间隙。
- 未使用时，务必拔下烤箱电源插头。

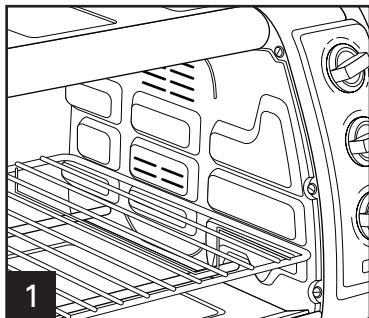

插上电源插头，请将烤架置于底层烤架位置（如图所示）。

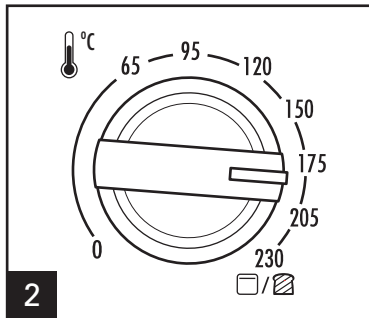

将温度设定旋钮旋至所需温度。

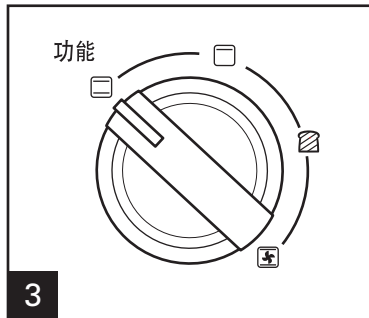

将功能旋钮旋至  (烘烤)。

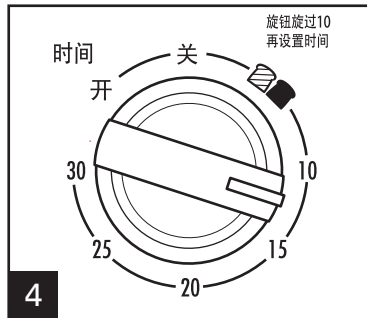

把食材放入烤箱前，将定时器旋钮旋至超过 10 分钟位置，让烤箱预热 5 分钟。

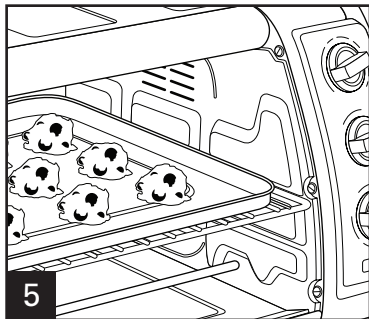

将烤盘放在烤架上。旋转定时器旋钮超过 10 分钟至所需烘烤时间位置，或将定时器旋钮旋至开的位置。

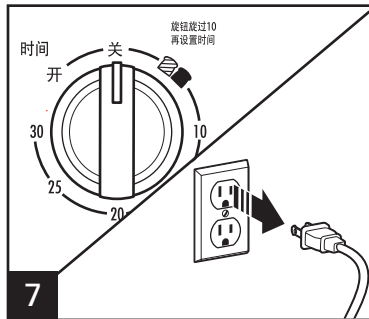
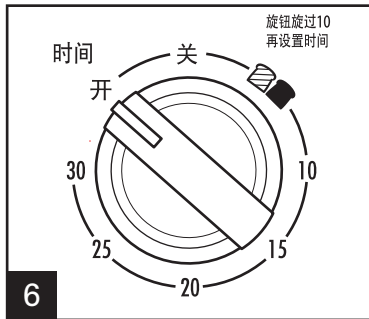

完成后，将定时器旋钮旋至关，并拔下电源插头。

如何烘烤（续）

- 请勿用锡箔纸完全包裹食材。锡箔纸可将食材隔热，减缓加热。
- 要加热面包卷或饼干，请将其放在烤盘上并以 300°F（149°C）温度加热 10 分钟。
- 要加热吃剩的烤肉或炖肉，需以 350°F（177°C）的温度，加热 20 至 30 分钟或直至完全热透。
- 使用**底层烤架位置**加热烘烤如披萨之类的食材。将食材直接放在烤架或烤盘上。
- 使用**底层烤架位置**加热烘烤如整鸡之类的食材。将食材放入烤盘中。
- 对流模式：当烤披萨时，使用对流模式可将烹饪时间缩短 25%。
- 烹饪达到一半时间时将食材翻面。

对流式烘烤

⚠ 警告 火灾危险。

- 如果烤箱内物件着火，请勿打开烤箱门。拔下烤箱电源插头，让着火物件停止燃烧并冷却后再打开烤箱门。

- 请勿使用烤箱蒸煮袋。
- 务必在食材和加热元件之间保留至少 1 英寸 (2.5 厘米) 间隙。
- 未使用时，务必拔下烤箱电源插头。

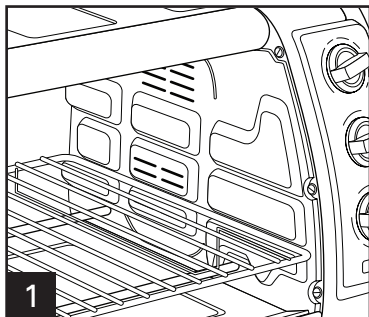

1 插上电源插头，请将烤架置于底层烤架位置。将温度设定旋钮旋至所需温度。

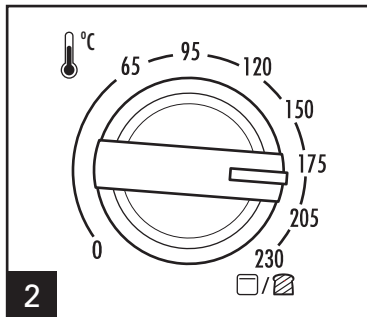

2

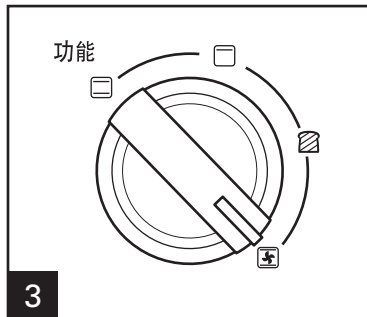

3

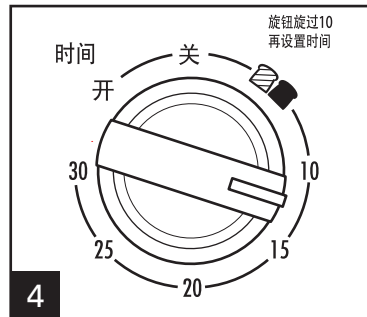

4

将功能旋钮旋至  (对流)。在开始烘烤前，将定时器旋钮旋至超过 10 分钟位置，让烤箱预热 5 分钟。烤箱预热后，旋转定时器旋钮超过 10 分钟至所需烘烤时间位置，将定时器旋钮旋至开。

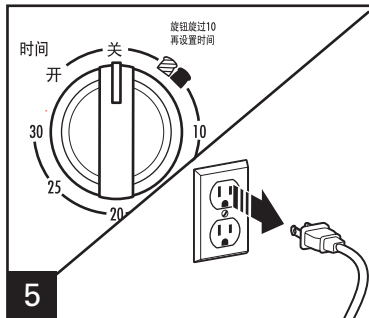

5 完成后，将定时器旋钮旋至关并拔下电源插头。

对流烘烤小贴士

注意：对流式烘烤驱使大量的空气在烤箱中循环，相比传统烘烤设置对流式烘烤可以将食材更快煮熟。

- 按同样的烤箱温度进行烘烤，但更节省时间。
- 或
- 按与传统烘烤相同的时间进行烘烤，但温度能减少至少 25%。
- 当烤披萨时，使用对流模式可将烹饪时间缩短 25%。

如何烧烤

警告 火灾危险。

- 如果烤箱内物件着火，请勿打开烤箱门。拔下烤箱电源插头，让着火物件停止燃烧并冷却后再打开烤箱门。
- 请勿让电器在工作期间处于无人看管状态。

- 请勿在玻璃门处于打开或取下状态时操作。
- 食材和加热元件之间保留至少 1 英寸 (2.5 厘米) 间隙。
- 请勿使用烤箱蒸煮袋。
- 请勿在热塑容器中加热食材。
- 请遵循食材制造商的说明。

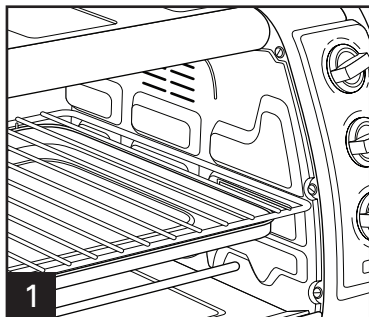

1

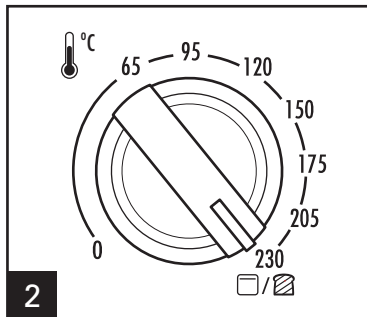

2

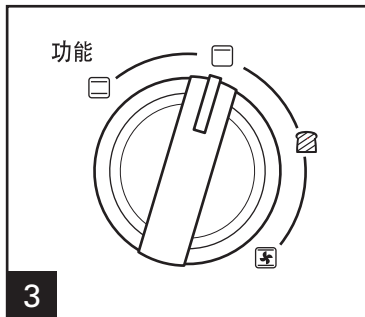

3

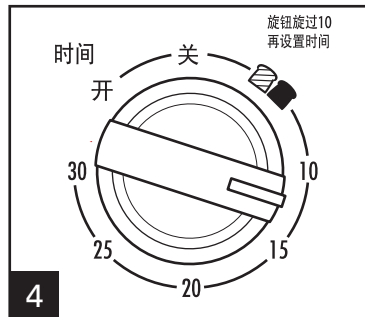

4

插上电源插头，将烤架放入到**顶层烤架位置**。将烤盘插入到烤架下方的插槽中，然后将食材添加至烤架上。请勿预热烤箱。将温控器旋钮旋至 (烧烤/烤面包)。

将功能旋钮旋至 (烧烤)。将定时器旋钮旋至超过 10 分钟，然后旋至所需烧烤的时间，或将定时器旋钮旋至**开**。烤焦黄时或中途将食材翻面。

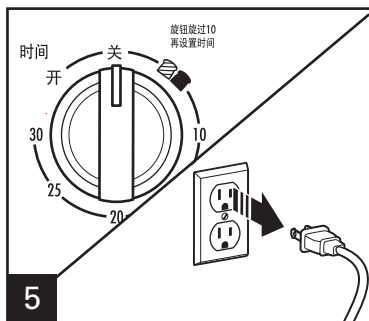

5

完成后，将定时器旋钮旋至**关**并拔下电源插头。

- 牛肉烤到不低于温度 145°F (63°C)。
- 碎肉和猪肉烤到不低于温度 160°F (71°C)。
- 鸡肉烤到不低于温度 165°F (73°C)。
- 鱼烤到不低于温度 145°F (63°C) 持续烧烤或至不透明状或可用餐叉剥落鱼肉时。

保养与清洗

警告

电击危险。

请勿使用金属清洁球清洁设备。金属清洁球可能会有部分金属脱落，并触碰电气元件。

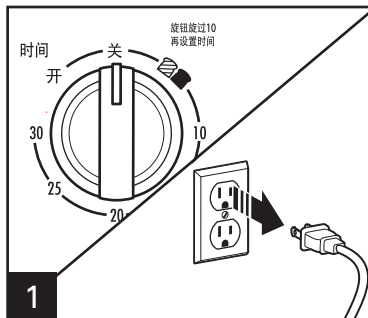

1 完成后，将定时器旋钮旋至关并拔下电源插头。

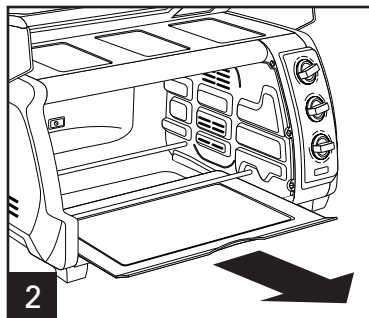

2 使用带清洁剂的湿布清洁烤箱内部、擦拭烤箱壁、烤箱底部和玻璃门。使用蘸清洁剂湿布重复擦拭。对于顽固污迹，则使用塑料清洁垫擦拭。

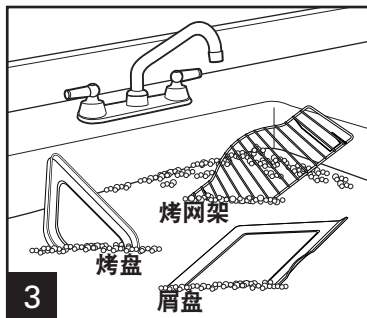

3 放入有清洁剂的温水中手洗、清洗，然后晾干。

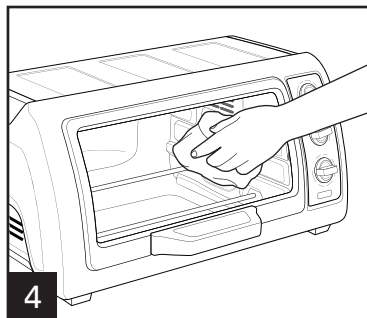

4 请使用湿布擦拭烤箱外部。请勿使用磨砂清洗剂或金属清洁垫。

故障排除

问题

可能的原因/解决方案

烤箱无法加热。

- 检查确定电源插座是否正常工作且烤箱插头已插上。将温度控制旋钮旋至 350°F (177°C)，然后将定时器旋钮旋至开。

烘烤时，烤箱门内表面出现水雾。

- 这属于烤箱烘烤的正常现象。水份从烤箱中散发出来的速度慢于从多士炉中散发出来的速度。新鲜面包、百吉饼和速冻面点所散发的水汽量各有不同。

烤箱散发异味和冒烟。

- 大部分发热类器具初次使用时出现冒烟和异味属正常现象。初次加热后，这些现象将会消失。

烤箱无法烤面包。

- 检查确定电源插座是否正常工作且烤箱插头已插上。将温度控制旋钮旋至  (烧面包) 然后将定时器旋钮旋至超过 10 分钟，然后再往回旋至所需烘焙色泽。

部分食材烧焦而部分未熟。

- 调整烤箱温度或烹饪时间，实现所用配方的最佳效果。

从烤箱门的顶部边角冒浓缩蒸汽。

- 烤箱中溢出的水分将冷凝成蒸汽从烤箱门上角冒出。这看上去似烟气。此属本产品的正常现象。

访问 www.hamiltonbeach.cn，了解我们完整的产品系列和使用及护理指南，以及美味配方、小贴士和在线注册您的产品。

Model/型号:
31126-CN

Type/类别:
O59

Capacity/容积:
16升

Rating/规格:
220-240V, 50/60Hz, 1400W

Dist.: Hamilton Beach Brands, Inc., Glen Allen, VA 23060
© 2015 Hamilton Beach Brands, Inc.

以上内容如有改动，恕不预先通知

840253801