

READ BEFORE USE

使用前阅读

Visit www.hamiltonbeach.cn for our complete line of products and Use and Care Guides – as well as delicious recipes, tips, and to register your product online!

有关我们所有系列产品的，使用与维护指南 – 以及美味食谱、生活小贴士和产品在线注册的更多信息，请访问 www.hamiltonbeach.cn。

Questions?
Please call us – our friendly associates are ready to help.
China: 400-852-2655

如有疑问？
请致电我们，我们的团队随时准备为您提供帮助。
中国大陆客服热线：
400-852-2655
官方网站：www.hamiltonbeach.cn
型号：52400-CN

此说明书中图片仅供参考，
产品以实物为准。

使用产品前请仔细阅读本使用说明书，
并妥善保管。

Hamilton 汉美驰 Beach®



Stay or Go Blender 多功能搅拌料理机

English 2
简体中文 12

IMPORTANT SAFEGUARDS

When using electrical appliances, basic safety precautions should always be followed to reduce the risk of fire, electric shock, and/or injury to persons, including the following:

1. Read all instructions.
2. This appliance is not intended for use by persons (including children) with reduced physical, sensory, or mental capabilities, or lack of experience and knowledge, unless they are closely supervised and instructed concerning use of the appliance by a person responsible for their safety.
3. Close supervision is necessary when any appliance is used by or near children. Children should be supervised to ensure that they do not play with the appliance.
4. To protect against risk of electrical shock, do not put cord, plug, base, or motor in water or other liquid.
5. Unplug cord from outlet when not in use, before putting on or taking off parts, and before cleaning.
6. Avoid contact with moving parts.
7. Do not operate any appliance with a damaged cord or plug, or after the appliance malfunctions, or is dropped or damaged in any manner. Call our customer service number for information on examination, repair, or electrical or mechanical adjustment.
8. The use of attachments, including canning jars, not recommended or sold by the appliance manufacturer may cause a risk of injury to persons.
9. Do not use outdoors.
10. Do not let cord hang over edge of table or counter or touch hot surfaces, including stove.
11. Keep hands and utensils out of blending jar while blending to reduce the risk of severe personal injury and/or damage to blender. A rubber spatula may be used but must be used only when blender is not running.
12. Blades are sharp; handle carefully—especially when assembling, disassembling, or cleaning inside blending jar.
13. Do not use a broken, chipped, or cracked blending jar.
14. Do not use broken, cracked, or loose cutting blade assembly.
15. To reduce the risk of injury, never place cutting blade assembly on base without blending jar or grinding cup properly attached.
16. Always operate blender with lid in place.
17. Do not blend hot liquids in the travel jar or grinding cup.
18. When blending hot liquids in the 32-oz. blending jar, remove center piece of two-piece cover. Hot liquids may push lid off jar during blending. To prevent possible burns: Do not fill blending jar beyond the 3-cup (710-ml) level. With the protection of an oven mitt or thick towel, place one hand on top of lid. Keep exposed skin away from lid. Start blending at lowest speed.
19. Ensure collar on base of blending jar, travel jar, and grinding cup are tight and secure. Injury can result if moving blades accidentally become exposed.
20. If the jar should twist or rotate when the motor is switched ON (I), switch OFF (O) immediately and tighten jar in collar or on blender base.
21. Do not leave blender unattended while it is operating.
22. Before plugging cord into wall outlet, turn the control to OFF (O). To disconnect cord, turn the control to OFF (O). Then remove plug from wall outlet.
23. Do not use appliance for other than intended purpose.
24. Do not place on or near a hot gas or electric burner or in a heated oven.
25. **CAUTION:** In order to avoid a hazard due to inadvertent resetting of the thermal cut-out, this appliance must not be supplied through an external switching device, such as a timer, or connected to a circuit that is regularly switched on and off by the utility.

SAVE THESE INSTRUCTIONS!

Other Consumer Safety Information

This appliance is intended for household use only. Use for food or liquids only.

The length of the cord used on this appliance was selected to reduce the hazards of becoming tangled in or tripping over a longer cord. If a longer cord is necessary, an approved extension cord may be used. The electrical rating of the extension cord must be equal to or greater than the rating of the appliance. Care must be taken to arrange the extension cord so that it will not drape over the countertop or tabletop where it can be pulled on by children or accidentally tripped over.

Wattage/Peak Power Information

The wattage/ampere rating of the blender is determined by an Underwriters Laboratory test and is based on available cutting blade assembly, jar combinations, and attachments that may not be provided with your unit, but are available as replacement parts. This is a measure of input wattage/amperes after 30 seconds of operation. The blender as provided may draw significantly less power.

Peak power is the measure of the motor wattage during the first seconds of operation. This is when a blender requires the most power to crush ice, frozen fruit, etc. This is a better measure of what a blender motor can consume when power is needed most.

If the cutting blade assembly locks and will not move, it will damage the motor. Do not use. Call the customer service number for information.

Do not place blending jar in the freezer filled with food or liquid. This can result in damage to the cutting blade assembly, jar, blender, and possibly result in personal injury.

BEFORE FIRST USE: After unpacking blender, wash everything except blender base in hot, soapy water. Dry thoroughly. Wipe blender base with a damp cloth or sponge. **DO NOT IMMERSE BASE IN WATER.** Care should be taken when handling cutting blade assembly as it is very sharp.

This machine is equipped with motor overload protection. If the motor stops during operation due to overheating, unplug and allow it to cool down for 30 minutes. Plug machine back in after 30 minutes to resume normal operation.

Parts and Features

BEFORE FIRST USE: After unpacking the blender, follow the instructions in "Care and Cleaning."



Using Your Blending Jar

IMPORTANT: Your blending jar and cutting blade assembly are subject to wear during normal use. Always inspect jar for nicks, chips, or cracks. Always inspect cutting blade assembly for broken, cracked, or loose blades. If jar or cutting blade assembly is damaged, do not use. Call our customer service number to obtain replacement parts.

⚠ WARNING Laceration Hazard.

Handle blades carefully; they are very sharp. Make sure unit is turned OFF (O) and is unplugged.

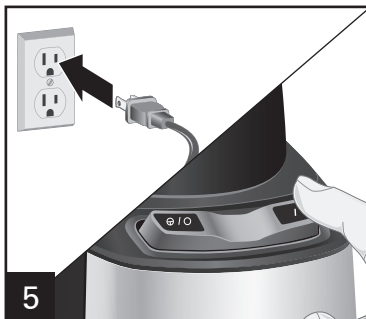
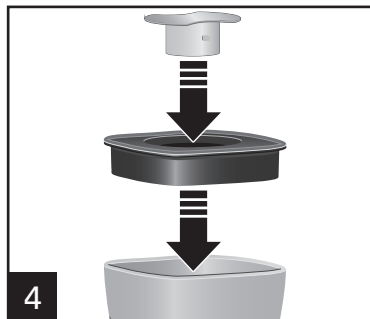
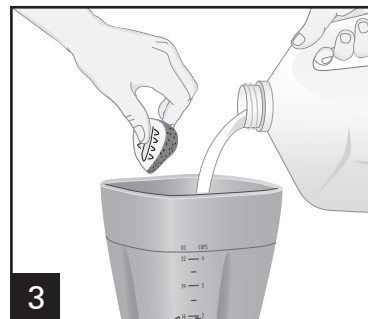
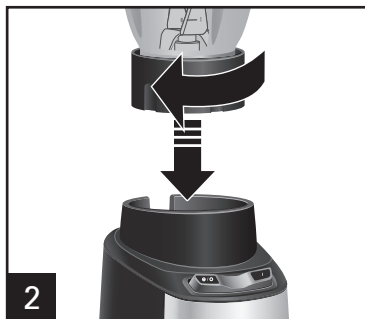
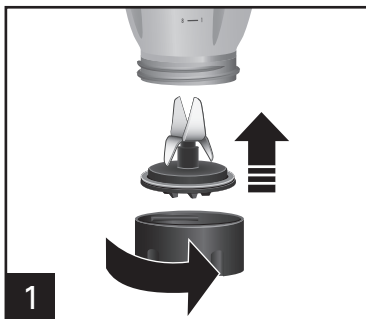

WARNING! Burn Hazard: Do not blend hot liquids in the travel jar or grinding cup. When blending hot liquids, remove filler-cap. Hot liquids may push lid off jar during blending. To prevent possible burns: Do not fill blending jar beyond the 3-cup (710-ml) level. With the protection of an oven mitt or thick towel, place one hand on top of lid. Keep exposed skin away from lid. Start blending at lowest speed.

Push the desired speed button. When using the **PULSE** button, the blender will only run when the button is held down.

6 – OPTIONAL

Using Your Blending Jar (cont.)

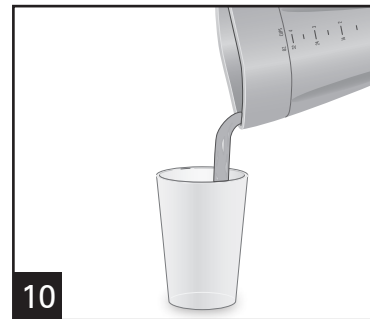
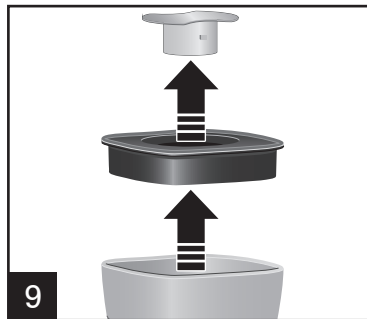
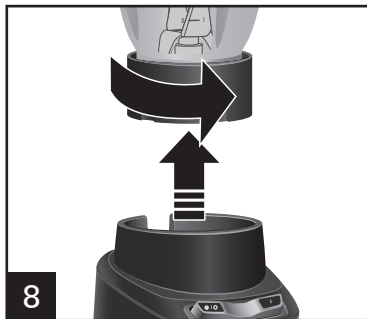
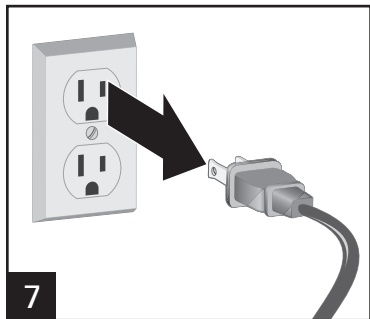

Blender Tips

- To add foods when blender is operating, remove filler-cap from lid and add ingredients through the opening.
- For best performance in the 32-oz. blending jar, the minimum amount of liquid needed per recipe is 1 cup (8 ounces/237 ml). The 16-oz. travel jar requires 3/4 cup (177 ml) liquid per recipe for best performance. Add more liquid if food is not blending properly.
- If blending action stops during blending or ingredients stick to sides of the jar, there may not be enough liquid in the jar to blend efficiently.
- Do not try to mash potatoes, mix stiff dough, whip egg whites, grind raw meat, or extract juices from fruits and vegetables.
- Do not store food or liquids in the blending jar.
- Avoid bumping or dropping the blender when in operation or at any time.

Using the Travel Jar

⚠ WARNING Burn Hazard.

Do not blend hot ingredients. Pressure may build, causing jar to pop off and hot ingredients to erupt.

⚠ WARNING Laceration Hazard.

Handle blades carefully; they are very sharp. Make sure unit is turned OFF (O) and is unplugged.

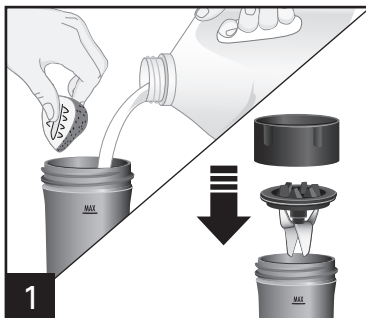

Add ingredients to travel jar. Carefully place cutting assembly and collar onto travel jar.

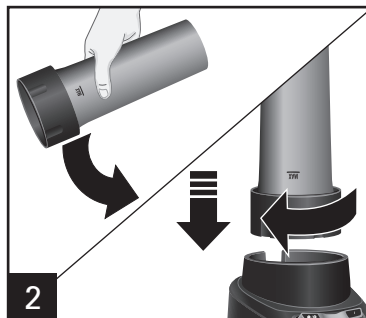

Turn travel jar upside down and place onto base.

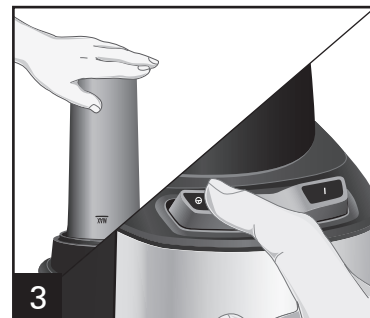

Hold jar in place while blending. Plug into outlet. Press **ON (I)** or **PULSE** to blend 15 to 30 seconds or until smooth. Always operate on a countertop or other supporting surface.

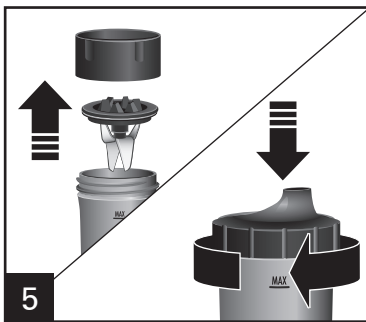
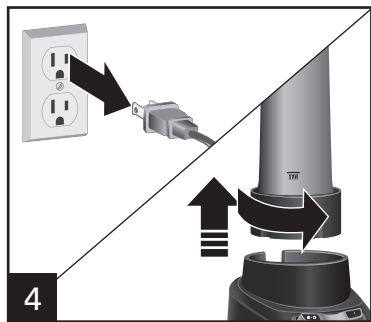

Turn bottom up; remove collar and cutting blade assembly from jar. Hand-tighten drinking lid onto travel jar.

Blending Tips for the 16-oz. Travel Jar

- For best performance in the 16-oz. travel jar, the minimum amount of liquid needed per recipe is 3/4 cup (6 ounces/177 ml).
- Do not chop or process hard foods such as cheese, crackers, or meat.
- If blending action stops during blending or ingredients stick to sides of the jar, turn blender OFF (O). Remove jar, collar, and blade and use a narrow rubber spatula to stir.
- Do not process hot foods or liquids in travel jar.
- Avoid bumping or dropping the blender.
- If blender stops working, unplug and allow 15 minutes before using. Plug into outlet to start blending.

Blending Drinks

TIPS FOR BEST RESULTS:

- Always place liquid in blending jar first, then remaining ingredients.
- If ice is not blending, stop blender and pulse a few times.

TYPE OF DRINK	INGREDIENTS (32 oz.)	INGREDIENTS (16 oz.)	BLENDER SETTING/TIME
Fruit Smoothie	1 1/2 cups (355 ml) milk 2 cups (473 ml) yogurt 2 1/2 cups (591 ml) frozen berries or other fruit Serves: 4–5	3/4 cup (177 ml) milk 3/4 cups (177 ml) yogurt 1 cup (237 ml) frozen berries or other fruit Serves: 1–2	PULSE for 15 seconds. Press ON (I) and blend until well blended.
Milkshake	1 3/4 cups (414 ml) milk 4 large scoops ice cream 1/4 cup (59 ml) flavored syrup Serves: 4–5	1 cup (237 ml) milk 2 large scoops ice cream 2 to 3 Tablespoons (30 to 44 ml) flavored syrup Serves: 1–2	Press ON (I) and blend until well blended.
Frozen Drink	2 cups (473 ml) drink mix, such as Piña Colada mix 4 oz. (118 ml) liquor, if desired 20 ice cubes Serves: 4–5	1 cup (237 ml) drink mix, such as Piña Colada mix 2 oz. (59 ml) liquor, if desired 10 ice cubes Serves: 2–3	PULSE for 30 seconds. Press ON (I) and blend until well blended.

Grinding Food

TIPS FOR BEST RESULTS:

- Press **PULSE** until food is the desired texture.
- Parmesan cheese and other hard cheeses should remain refrigerated prior to blending.

FOOD	MAX AMOUNT IN GRINDING CUP	PREPARATION
Parmesan Cheese	4 oz. (113 g)	1/2-in. (1.3-cm) cubes
Nuts	1/2 cup (118 ml)	None
Cookie or Cracker Crumbs	1/2 cup (118 ml)	Break cookies or crackers into pieces
Coffee Beans	1/2 cup (118 ml)	None

Using the Grinding Cup

⚠ WARNING Laceration Hazard.

Ensure unit is OFF (O) and unplugged before attaching grinding cup. Do not plug in and turn on until cup is secured onto base.

Always turn OFF (O), unplug, and allow blade to stop spinning before removing from base. Handle blades carefully; they are very sharp.

⚠ WARNING Burn Hazard.

Do not blend hot ingredients. Pressure may build, causing jar to pop off and hot ingredients to erupt.

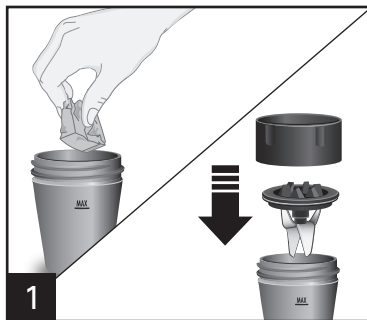

Add ingredients (no more than 1/2 cup or to the MAX fill line) to grinding cup. Carefully place cutting assembly and collar onto cup.

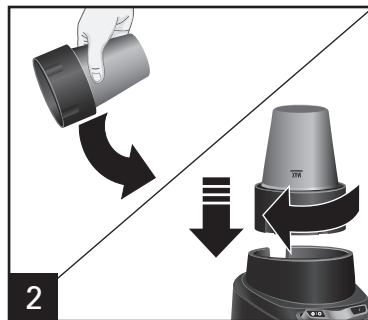

Turn cup upside down and place onto base.

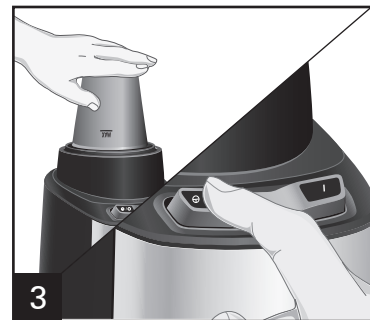

Hold cup in place while blending. Plug into outlet. Press **ON (I)** or **PULSE** to chop. Always operate on a countertop or other supporting surface.

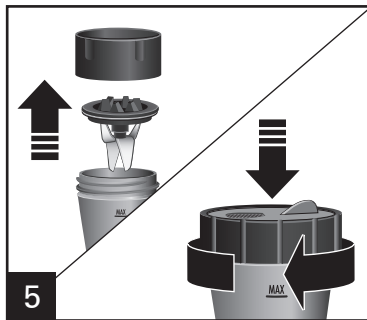
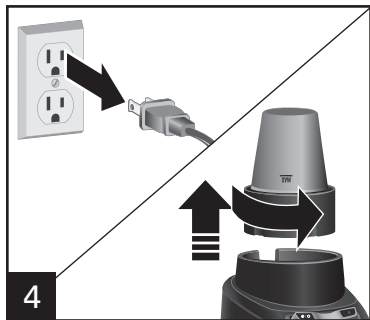

Turn bottom up, remove collar and cutting blade assembly from cup. Hand-tighten shaker/storage lid onto cup.

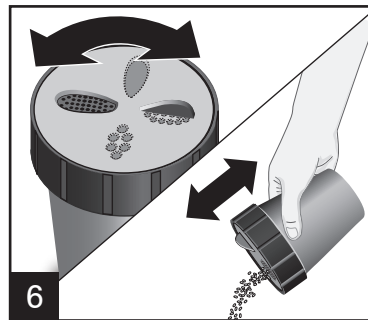

Turn top of lid to desired hole size. Shake to dispense.

NOTE: Do not blend liquid ingredients in the 8-oz. grinding cup.

Care and Cleaning

⚠️ WARNING Electrical Shock Hazard.

Disconnect power before cleaning. Do not immerse cord, plug, base, or motor in water or other liquid.

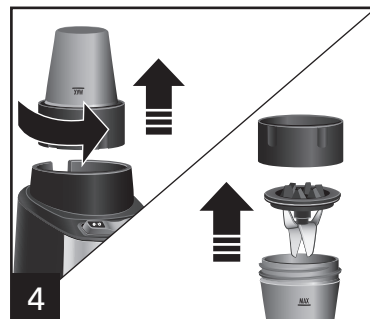
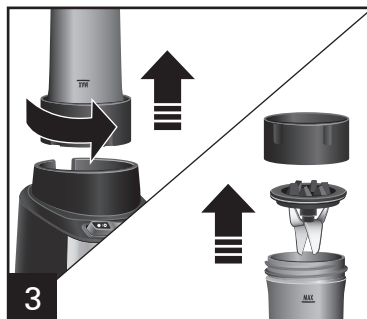
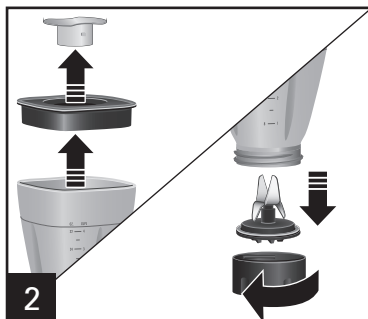
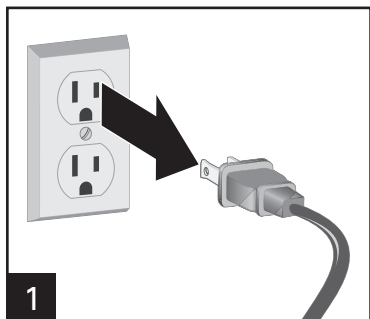

Wipe blender base, control panel, and cord with a damp cloth or sponge. To remove stubborn spots, use a mild, nonabrasive cleanser.



DO NOT use the "SANI" setting when washing in the dishwasher. "SANI" cycle temperatures could damage your product. Parts may also be washed with hot, soapy water. Care should be taken when handling the cutting blade assembly as it is very sharp. Rinse and dry thoroughly. Do not soak.

EASY CLEAN: To Easy Clean, pour 2 cups (473 ml) warm water into 32-oz. jar and add 1 drop liquid dishwashing detergent. Press **ON (I)** and blend for 10 seconds. Discard soapy water. Rinse with clean water. To Easy Clean the travel jar and grinding cup, repeat directions above, except reduce warm water to 3/4 cup (177 ml).

This is not a substitute for regular cleaning as instructed in "Care and Cleaning."

Easy Clean should only be used to rinse the blender between batches of processing the same food. When the processing of a single type of food is finished, the blender should be disassembled and thoroughly cleaned as instructed in "Care and Cleaning."

Recipes for 32-oz. Blending Jar

Triple Berry Smoothie

1/2 cup (118 ml) cranberry-raspberry juice
1 cup (237 ml) fresh strawberries, hulled
1 cup (237 ml) fresh raspberries
1/2 cup (118 ml) fresh blueberries
1/2 cup (118 ml) vanilla yogurt
10 ice cubes

Directions:

1. Place ingredients in blending jar in order listed.
2. Cover and blend until smooth.

TEST KITCHEN TIP: Try different combinations of fresh berries and juice to make new flavors of smoothies.

Serves: 4

Mango Smoothie

1/2 cup (118 ml) fresh orange juice
1/2 cup (118 ml) peach yogurt
2 Tablespoons (30 ml) honey
1 cup (237 ml) fresh mango
3–4 ice cubes

Directions:

1. Place ingredients in blending jar in order listed.
2. Cover and blend until smooth.

*Always place liquid ingredients in blender first.

Serves: 2–4

Vanilla Milkshake With Mix-Ins

3/4 cup (177 ml) milk
3 large scoops vanilla ice cream
1/4 cup (59 ml) crushed candy or cookies, optional

Directions:

1. Place ingredients in blending jar in order listed.
2. Cover and blend until smooth.

TEST KITCHEN TIPS:

- Always place liquid ingredients in blender first.
- For best results, crush candy or cookies before adding to milkshake. When milkshake is blended, pour crushed candy or cookies on top and PULSE blender 3 to 4 times to mix.

Serves: 2–3

Fresh and Spicy Salsa

1 onion, peeled and quartered
1 clove garlic
1 jalapeno pepper, stem removed
4 small tomatoes, quartered
1/4 cup (59 ml) cilantro
1 Tablespoon (15 ml) lime juice
1/2 teaspoon (2.5 ml) cumin
Salt and pepper to taste

Directions:

1. Place onion, garlic, and pepper in blender. Cover and PULSE until finely minced. Stir as needed. Stop blender.
2. Add tomatoes, cilantro, lime juice, cumin, salt, and pepper. Cover and PULSE until desired texture is reached, stirring as needed.

Serves: 6–8

重要安全说明

当使用电器时，应始终遵守基本的安全防范措施，以减少火灾、触电和 / 或人身伤害的风险，包括以下内容：

1. 阅读所有相关说明。
2. 本电器不适合以下人群（包括儿童）使用：行动不便者、精神或智商缺陷者、缺少经验和常识者，除非他们在监护人的密切监督和指导下使用，以确保安全。
3. 当电器由儿童使用或距离儿童较近时，需有成人看护。请勿将本电器用于儿童玩耍。
4. 为防止触电危险，请勿将电源线、插头底座或电机放入水或其他液体中。
5. 当本电器不使用时、安装 / 拆解部件和清洁该电器前，请从插座拔下电源。
6. 避免接触正在运动的部件。
7. 在下列情况下，请勿使用电器：电源线或插头破损、电器出现故障后、电器曾跌落或已经出现任何形式的损坏。请拨打我们的售后服务电话，咨询有关电器检查、修理或电气或机械调整的相关信息。如果电源软线损坏，为了避免危险，必须由制造商、其维修部或类似部门的专业人员更换。
8. 使用非本电器制造商推荐或出售的附件，包括搅拌杯，可能会造成人员受伤的风险。
9. 请勿户外使用。
10. 请勿将电源线搭置在桌台边缘上以及与发热表面接触，包括电炉。
11. 搅拌时保持双手及用具远离搅拌杯，以降低人员严重受伤或搅拌机损坏的风险。可使用橡胶刮铲，但仅限于在搅拌机未运行时使用。
12. 刀片很锋利，尤其在组装、拆解或清洁搅拌杯内部时，务必要小心处理。
13. 请勿使用破损、有裂口或裂痕的搅拌杯。
14. 请勿使用裂口、裂痕或松动的切割刀片组件。
15. 为了降低受伤风险，在未将搅拌杯或研磨杯正确安装前，禁止将切割刀片组件置于底座上。
16. 本机仅在提供的底座上使用，务必在搅拌杯或研磨杯盖子盖好后才操作搅拌机。
17. 请勿在旅行杯或研磨杯中搅拌热液体。
18. 在 32 盎司搅拌杯中搅拌热液体时，请取下两件式盖子的加料口盖。搅拌过程中热液体可能会推动盖子，为防止可能的烫伤：请勿超过搅拌杯的 3 杯（710 毫升）液位，并戴上烤箱手套或用厚毛巾进行保护，用戴手套的手压住盖子的顶部，让暴露的皮肤远离盖子，以最低速度开始搅拌。
19. 确保搅拌杯、旅行杯和研磨杯与杯座安装牢固。如果转动刀片意外暴露，则可能导致受伤。
20. 如果在电机开启 (I) 时搅拌杯有扭动或转动的情况，请立即关闭 (O) 电机，然后将搅拌杯紧固在杯座上或搅拌机底座上。
21. 请勿让搅拌机在无人看管的情况下运行。在更换附件或接触运动部件前要关掉电源开关并断开电源。
22. 在将电源线插入电源插座前，请将控制装置转动至关闭 (O) 位置。若要断开电源，请将控制装置转动至关闭 (O) 位置。然后从电源插座上拔下插头。
23. 请勿将该装置用于非预期用途。
24. 请勿置于燃气、电炉、热烤箱上面或附近。
25. 小心：为了避免由于热熔断器意外重置导致危险，本电器不能在外接定时器或独立的遥控控制系统的方式下运行。

请妥善保管说明书！

其他用户安全信息

此电器建议于家庭使用。仅可用于搅拌食物或液体。

此电器电源线的长度经过设计挑选，以减少长电源线缠绕或绊倒的危险。倘若需要更长的电源线，可使用有认证的电源延长线。电源延长线的额定功率必须等于或大于此电器的额定功率。电源延长线使用时需特别注意，以防将其搭设在工作台或桌面上，造成儿童扯拉或绊倒他人。

功率 / 峰值功率信息

搅拌机的功率 / 安培额定值通过实验室试验确定，基于可用切割刀片组件、搅拌杯及可用作更换零件的附件的情况下得出。这是运行 30 秒后输入功率 / 安培的测量值。

峰值功率是最初几秒运行过程中电机功率的测量值。搅拌机需要最大功率粉碎冰块、冰冻水果等时会出现峰值功率。这是在最大程度需要功率时，搅拌机电机可消耗的功率值。

如果切割刀片组件锁住而不能移动，可能会损坏电机。请勿使用。有关信息，请拨打售后服务电话。

请勿将装有食物或液体的搅拌杯放入冰箱中。这可能导致切割刀片组件、搅拌杯、搅拌机损坏及可能的人身伤害。

首次使用前：拆开搅拌机的包装后，用带清洁剂的温水清洗除搅拌机底座以外的所有组件。彻底晾干。用湿布或海绵擦拭搅拌机底座。请勿将底座浸入水中。处理切割刀片组件时要非常小心，因为它非常锋利。

本机配有过热保护。在操作期间如果电机因过热而停止，请拔掉电源插头并让机器冷却 30 分钟。30 分钟后再插上机器的电源插头以恢复正常操作。

部件和功能

首次使用前：拆开搅拌器的包装后，请遵循“保养与清洗”中的说明

⊕ / ○	点动 / 关机
	启动



使用您的搅拌杯

重要：您的搅拌杯和切割刀片组件在正常使用过程中可能会磨损。请务必检查搅拌杯是否有裂纹、缺口或裂缝。请务必检查切割刀片组件是否有破损、破裂或松动。如果搅拌杯或切割刀片组件损坏，请勿使用。请拨打我们的客服电话，以获得更换部件。

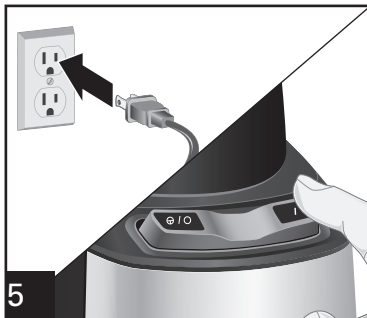
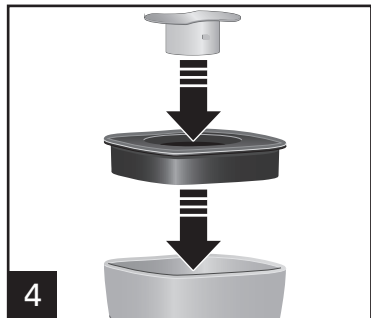
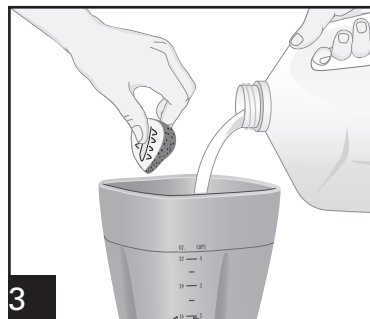
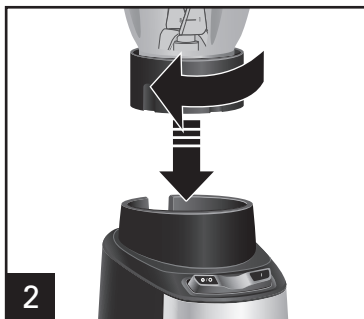
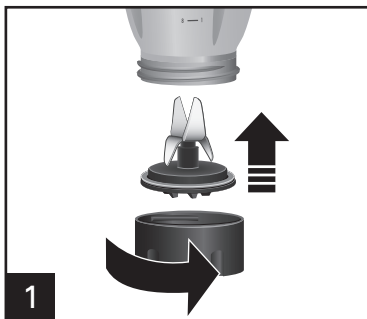

警告 割伤危险。

请小心处理刀片；它们十分锋利。确保本机关闭 (O) 且拔下插头。

按下所需的速度按钮。使用点动按钮时，搅拌机仅在持续按住该按钮才运行。

警告！烫伤危险：请勿在旅行杯或研磨杯中搅拌热液体。搅拌热液体时，取下加料口盖。搅拌过程中热液体可能会推动盖子。为防止可能的烫伤，请勿超过搅拌杯的 3 杯（710 毫升）液位。戴上烤箱手套或用厚毛巾进行保护，用戴手套的手压住盖子的顶部，让暴露的皮肤远离盖子，以最低速度开始搅拌。

使用旅行杯 (续)

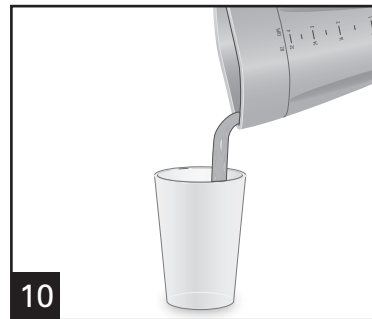
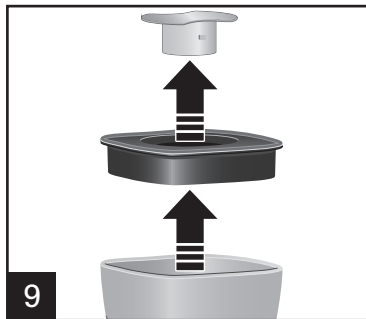
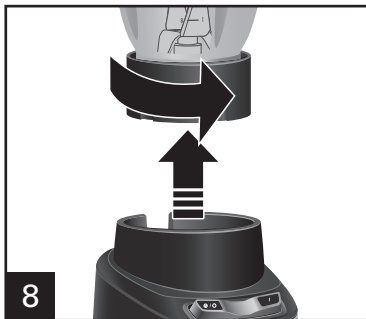
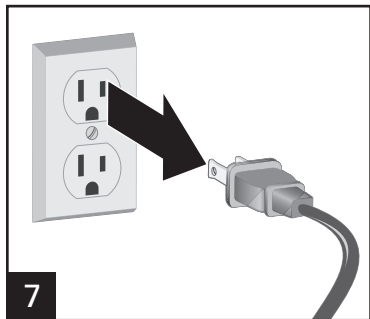

搅拌机小贴士

- 若要在搅拌机运行时加入食物，请从盖子上取下加料口盖，并通过开口加入食材。
- 为在使用 32 盎司搅拌杯时获得最佳性能，每种食谱至少需要一杯液体（8 盎司 / 237 毫升）。使用 16 盎司旅行杯时，每种食谱需要 3/4 杯（177 毫升）液体，才可获得最佳性能。如果食物未能搅拌均匀，请加入更多液体。
- 如果搅拌过程中搅拌操作停止或食材粘在搅拌杯侧面，搅拌杯中的液体可能不够，不能进行充分搅拌。
- 请勿尝试捣烂土豆、搅拌硬面、打蛋清、磨生肉或从水果和蔬菜中提取汁液。
- 请勿将食物或液体储存在搅拌杯中。
- 避免在运行过程中或在任何时间碰撞搅拌机或使其跌落。

使用旅行杯

警告 烫伤危险。

请勿搅拌热食材。压力可能聚集，导致搅拌杯弹出，热食材喷出。

警告 割伤危险。

请小心处理刀片；它们十分锋利。确保本机关闭 (O) 且拔下插头。

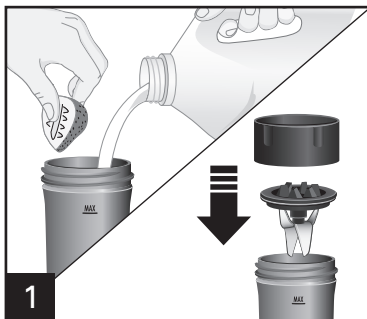

1 将食材添加至旅行杯中。小心将切割刀片组件和杯座组装到旅行杯上。

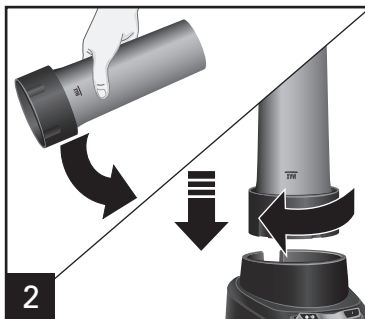

2 将旅行杯倒转并旋紧固定到底座上。

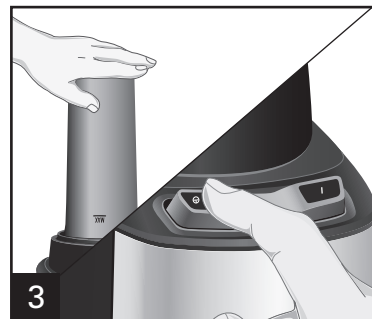

3 搅拌时将搅拌杯固定在底座上。插上插头。按启动或点动以搅拌 15 至 30 秒钟或直到均匀。务必在台面或其他支撑表面进行操作。

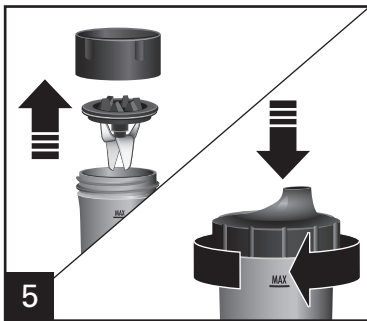
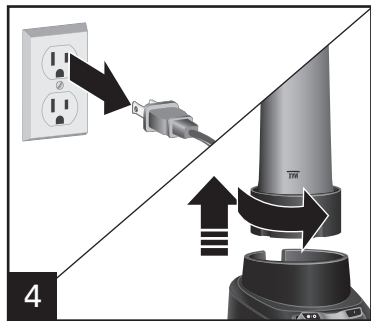

4 转底向上；从搅拌杯上取下杯座和切割刀组件。用手将饮用杯盖拧紧到旅行杯上。

16 盎司搅拌杯的小贴士

- 为在使用 16 盎司旅行杯时获得最佳性能，每种食谱至少需要 3/4 杯液体 (6 盎司 / 177 毫升)。
- 请勿使用本装置剁碎或处理较硬的食物，如奶酪、饼干或肉类。
- 如果搅拌过程中搅拌操作停止或食材粘在搅拌杯侧面，请将搅拌机关闭 (O)。取下搅拌杯、杯座、刀片，并使用橡皮刮刀进行搅拌。
- 请勿在旅行杯中处理热食物或液体。
- 避免碰撞搅拌机，不要让其跌落。
- 如果搅拌机停止工作，请拔下插头，等待 15 分钟后再次使用。插入电源插座，开始搅拌。

搅拌饮料

最佳效果小贴士:

- 务必先将液体放在搅拌杯中, 然后再放剩余的食材。
- 如果冰块搅不动, 请停止搅拌机, 并按“点动”几次。

饮料类型	食材 (32 盎司)	食材 (16 盎司)	搅拌机设置 / 时间
水果冰沙	1 杯半 (355 毫升) 牛奶 2 杯 (473 毫升) 酸奶 2 杯半 (591 毫升) 冷冻浆果或其他水果 份量: 4-5	3/4 杯 (177 毫升) 牛奶 3/4 杯 (177 毫升) 酸奶 1 杯 (237 毫升) 冷冻浆果或其他水果 份量: 1-2	按住“点动”15 秒。 然后按 启动 按钮, 直至搅拌均匀。
奶昔	1 3/4 杯 (414 毫升) 牛奶 4 大勺冰淇淋 1/4 杯 (59 毫升) 调味糖浆 份量: 4-5	1 杯 (237 毫升) 牛奶 2 大勺冰淇淋 2 ~ 3 汤匙 (30 ~ 44 毫升) 调味糖浆 份量: 1-2	按 启动 按钮, 直至搅拌均匀。
冷冻饮品	2 杯 (473 毫升) 混合饮料, 如椰味饮料预伴汁 4 盎司 (118 毫升) 酒, 如需要 20 个冰块 份量: 4-5	1 杯 (237 毫升) 混合饮料, 如椰味饮料预伴汁 2 盎司 (59 毫升) 酒, 如需要 10 个冰块 份量: 2-3	按住“点动”30 秒。 按 启动 按钮, 直至搅拌均匀。

研磨食物

最佳效果小贴士:

- 按住**点动**按钮直至食材达到所需细度。
- 帕玛森奶酪和其他硬奶酪在搅拌前应保持冷藏。

食物	研磨杯中的最大量	准备
帕玛森奶酪	4 盎司 (113 克)	1/2 英寸 (1.3 厘米) 块
坚果	半杯 (118 毫升)	无
饼干或饼干屑	半杯 (118 毫升)	将饼干打成碎片
咖啡豆	半杯 (118 毫升)	无

使用研磨杯

⚠警告 割伤危险。

确保本装置关机 (O) 并拔下电源插头，然后才可安装研磨杯。请勿插上电源，直至杯子已固定在底座上，才打开电源。从底座上取下前，务必关机 (O)，拔下插头并让刀片停止旋转。请小心处理刀片；它们十分锋利。

⚠警告 烫伤危险。

请勿搅拌热食材。压力可能聚集，导致搅拌杯弹出，热食材喷出。

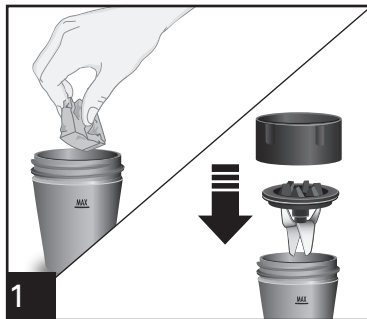

1 将食材（不超过半杯或最大注入液位线）添加至研磨杯。小心将切割刀片组件和杯座安装到杯子上。

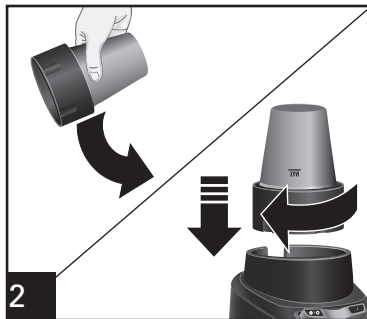

2 将杯子倒转并旋紧固定到底座上。

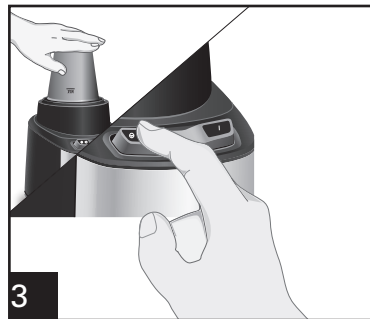

3 搅拌时将杯子固定在原位。插上插头。按启动或点动按钮进行切碎。务必在台面或其他支撑表面上进行操作。

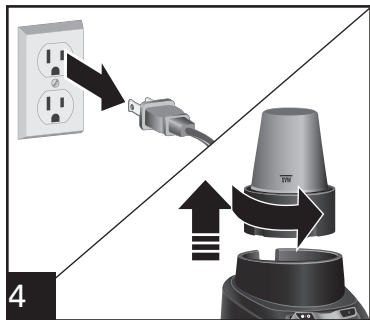

4

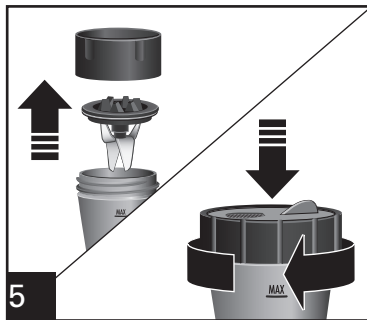

5

转底向上；从杯子上取下杯座和切割刀组件。将密封盖拧紧到杯子上。

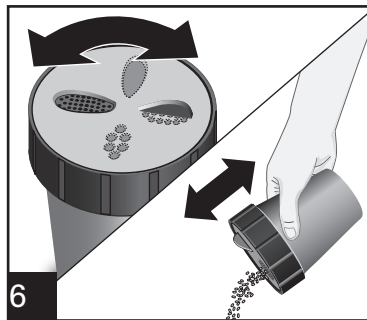

6

将盖子顶部转动至所需孔大小。倒出前先摇匀。

注意：请勿在 8 盎司研磨杯中搅拌液体食材。

保养与清洗

警告 电击危险。

清洁前断开电源。请勿将电源线、插头、基座或电机浸入水或其他液体中。

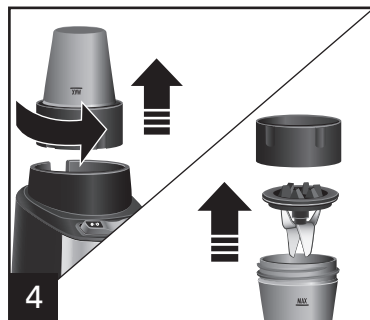
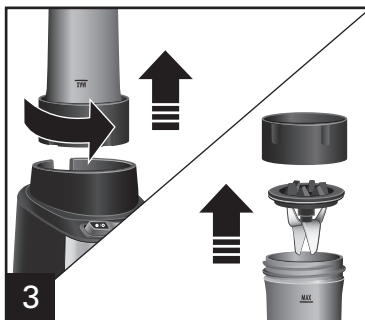
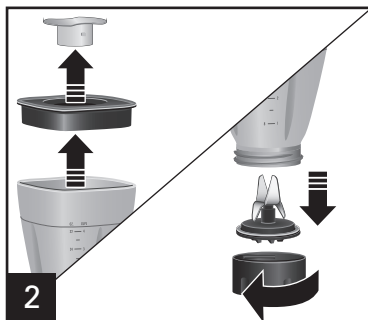
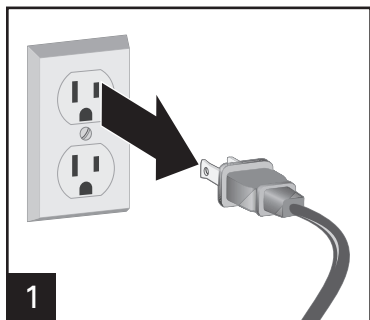

用湿布或海绵擦拭搅拌机底座、控制面板和电源线。若要去除顽固的斑点，请使用温和的防磨损清洁剂。



在洗碗机中清洗时，请勿使用消毒设置。消毒循环温度会损坏本产品。部件也可以在带清洁剂的温水中清洗。处理切割刀片组件时要非常小心，因为它非常锋利。冲洗，然后彻底晾干。请勿浸泡。

简易清洁：若要进行简易清洁，请将 2 杯（473 毫升）温水倒入 32 盎司搅拌杯中，然后加入 1 滴液体餐具洗涤剂。按启动按钮，搅拌 10 秒。倒掉带清洁剂的水，用清水冲洗。要对旅行杯和研磨杯进行简易清洁，请重复上述说明，将温水减少至 3/4 杯（177 毫升）。如“保养与清洗”中所示，这不适合定期清洁。

简易清洁功能应仅用于在加工相同食物的两个批次之间对搅拌机进行冲洗。单类食物的加工结束时，应拆卸搅拌机，并按照“保养与清洗”中的说明进行彻底清洁。

32 盎司搅拌杯的食谱

三莓冰沙

1/2 杯 (118 毫升) 酸果蔓覆盆子汁
1 杯 (237 毫升) 新鲜的草莓, 去蒂
1 杯 (237 毫升) 新鲜覆盆子
1/2 杯 (118 毫升) 新鲜蓝莓
1/2 杯 (118 毫升) 香草酸奶
10 个冰块

制作方法:

1. 将食材按列出的顺序放入搅拌杯中。
2. 盖上盖子, 搅拌直到混合均匀。

小贴士: 尝试新鲜莓果和果汁的不同组合, 制作不同口味的果汁。

份量: 4

芒果冰沙

1/2 杯 (118 毫升) 新鲜橙汁
1/2 杯 (118 毫升) 桃子酸奶
2 汤匙 (30 毫升) 蜂蜜
1 杯 (237 毫升) 新鲜芒果
3-4 个冰块

制作方法:

1. 将食材按列出的顺序放入搅拌杯中。
2. 盖上盖子, 搅拌直到混合均匀。

* 务必先将液体放入搅拌杯中。

份量: 2-4

香草奶昔混合饮品

3/4 杯 (177 毫升) 牛奶
3 大勺香草冰淇淋
1/4 杯 (59 毫升) 碎糖果或饼干, 可选

制作方法:

1. 将食材按列出的顺序放入搅拌杯中。
2. 盖上盖子, 搅拌直到混合均匀。

小贴士:

- 务必先将液体放入搅拌杯中。
- 为了获得最佳效果, 先将糖果或饼干弄碎, 然后再加入奶昔。搅拌奶昔时, 将碎糖果或饼干倒在顶部, 按点动按钮 3~4 次进行充分搅拌。

份量: 2-3

新鲜辣味莎莎酱

1 个洋葱, 去皮并分成四份
1 瓣大蒜
1 根辣椒, 去茎
4 个小西红柿, 分成四份
1/4 杯 (59 毫升) 香菜
1 汤匙 (15 毫升) 柠檬汁
1/2 茶匙 (2.5 毫升) 孜然
适量的盐和胡椒粉

制作方法:

1. 将洋葱、大蒜和胡椒放入搅拌机中。盖上盖子, 按下“点动”, 直到切碎。根据需要进行搅拌。停止搅拌机。
2. 加入西红柿、香菜、柠檬汁、孜然、盐和胡椒粉。盖上盖子, 按下“点动”, 直到达到所需细度, 根据需要进行搅拌。

份量: 6-8

食品接触材料信息



本产品符合相应食品安全国家标准要求，食品接触用材料及其执行标准的符合性信息说明如下：

序号	部件名称	材质	执行标准	备注
1	32 盎司搅拌杯、 16 盎司旅行杯、 8 盎司研磨杯	对苯二甲酸二甲酯和 1, 4-环己烷二甲醇， 2, 2, 4, 4-四甲基-1, 3-环丁二醇的聚合物 (改性 PCT)	GB4806.1-2016;GB4806.6-2016;GB4806.7-2016;	*
2	防漏垫片	乙烯与丙烯的共聚物 (合成橡胶)	GB4806.1-2016;GB4806.11-2016	/
3	盖子、饮用杯盖、 饮用杯盖出水盖	聚丙烯 (PP)	GB4806.1-2016;GB4806.6-2016;GB4806.7-2016	*
4	调味 / 储存盖 1	聚丙烯 (PP)	GB4806.1-2016;GB4806.6-2016;GB4806.7-2016	*
5	刀座	聚丙烯 (PP)	GB4806.1-2016;GB4806.6-2016;GB4806.7-2016	/
6	调味 / 储存盖 2	丙烯腈-丁二烯-苯乙烯共聚物 (ABS)	GB4806.1-2016;GB4806.6-2016;GB4806.7-2016	*
7	加料口盖	丙烯腈-苯乙烯共聚物 (AS)	GB4806.1-2016;GB4806.6-2016;GB4806.7-2016	*
8	密封圈	丁腈橡胶 (NBR)	GB4806.1-2016;GB4806.11-2016	/
9	衬套、垫片	不锈钢 06Cr19Ni10 (SUS 304)	GB4806.1-2016;GB4806.9-2016	/
10	切割刀片	不锈钢 12Cr17Ni7 (SUS 301)	GB4806.1-2016;GB4806.9-2016	/
11	切割刀轴	不锈钢 Y12Cr18Ni9 (SUS 303)	GB4806.1-2016;GB4806.9-2016	/

注：1. 特殊使用说明：请严格遵照说明书及产品所带附件资料使用本产品。

2. * 表示：该部件仅适用于部分型号，具体以实际产品为准。

产品中有害物质的名称及含量

Name and content of hazardous substances in product

部件名称 (Component name)	有害物质(hazardous substance)					
	铅 Lead (Pb)	汞 Mercury (Hg)	镉 Cadmium (Cd)	六价铬 Hexavalent Chromium (Cr(VI))	多溴联苯 Polybrominated biphenyls (PBB)	多溴二苯醚 Polybrominated diphenyl ethers (PBDE)
主动轮 (Driving Wheel)	X	O	O	O	O	O
翘板开关 (Rocker Switch)	O	O	X	O	O	O
微动开关 (Micro Switch)	O	O	X	O	O	O
马达 (Motor)	X	O	O	O	O	O

本表格依据 SJ/T 11364 的规定编制。This table is prepared in accordance with the provisions of SJ/T 11364.

O: 表示该有害物质在该部件所有均质材料中的含量均在 GB/T 26572 规定的限量要求以下。

Indicates that the said hazardous substance contained in all the homogeneous materials for this component is below the limit requirement in GB/T 26572.

X: 表示该有害物质至少在该部件的某一均质材料中的含量超出 GB/T 26572 规定的限量要求。这是由于目前技术或经济等的原因暂时无法实现替代。

Indicates that the said hazardous substance contained in at least one of the homogeneous materials used for this component is above the limit requirement in GB/T 26572. Due to technological and/ or economic reasons, these hazardous substances cannot be easily replaced at this time.



这是环保使用标志。标志内的数字代表在正常使用状态下，产品的环保使用推荐年限。

This is the logo of environmental protection use. The number inside indicates the environmental protection use recommended period (Year) of product in normal use.

Model/型号:
52400-CN

Type/类别:
B78

Capacity/容积:
1000毫升

Rating/规格:
220-240V, 50Hz, 250W

制造商: 汉密尔顿海滩电器(深圳)有限公司
地址: 深圳市福田区深南西路车公庙工业区天安数码时代
大厦主楼 1306-1308、1309-1311 单元
本产品执行标准: GB4706.1-2005, GB4706.30-2008

以上内容如有改动, 恕不预先通知



添加官方微博 微信
开启美食人生