

READ BEFORE USE

使用前阅读

Visit www.hamiltonbeach.cn for our complete line of products and Use and Care Guides – as well as delicious recipes, tips, and to register your product online!

有关我们所有系列产品的，使用与维护指南 – 以及美味食谱、生活小贴士和产品在线注册的更多信息，请访问 www.hamiltonbeach.cn。

Questions?

Please call us – our friendly associates are ready to help.
China: 400-852-2655

如有疑问？

请致电我们，我们的团队随时准备为您提供帮助。

中国大陆客服热线：

400-852-2655

官方网站：www.hamiltonbeach.cn

型号：25490-CN

此说明书中图片仅供参考，产品以实物为准。

使用本设备前，我们建议您仔细阅读这些说明。

Hamilton 汉美驰 Beach®



The Dual Breakfast Sandwich Maker 双盘早餐机

English 2

简体中文 12

IMPORTANT SAFEGUARDS

When using electrical appliances, basic safety precautions should always be followed to reduce the risk of fire, electric shock, and/or injury to persons, including the following:

1. Read all instructions.
2. This appliance is not intended for use, cleaning, or maintenance by persons (including children) with reduced physical, sensory, or mental capabilities, or lack of experience and knowledge, unless they are closely supervised and instructed concerning the use of the appliance by a person responsible for their safety. Children should be supervised to ensure they do not play with the appliance.
3. Cleaning and user maintenance shall not be made by children without supervision.
4. Do not touch hot surfaces. Use handles or knobs.
5. To protect against risk of electrical shock, do not immerse cord, plug, or cooking unit in water or other liquid.
6. Unplug from outlet when not in use and before cleaning. Allow to cool before putting on or taking off parts and before cleaning.
7. Do not operate any appliance with a damaged cord or plug, or after the appliance malfunctions or has been dropped or damaged in any manner. Call our toll-free customer service number for information on examination, repair, or adjustment. If the supply cord is damaged, it must be replaced by the manufacturer, its service agent or similarly qualified persons in order to avoid a hazard.
8. The use of accessory attachments not recommended by the appliance manufacturer may cause injuries.
9. Do not use outdoors.
10. Do not let cord hang over edge of table or counter or touch hot surfaces, including the stove.
11. Do not place on or near a hot gas or electric burner, or in a heated oven.
12. Do not use appliance for other than intended use.
13. Do not use appliance unattended.
14. During use, provide 4 to 6 inches air space above, behind, and on both sides for air circulation.
15. Never remove the food with any kind of cutting device or other metallic kitchen utensil.
16. Always allow the appliance to cool before putting it away, and never wrap the cord around the appliance while it is still hot.
17. **CAUTION:** In order to avoid a hazard due to inadvertent resetting of the thermal cut-out, this appliance must not be supplied through an external switching device, such as a timer, or connected to a circuit that is regularly switched on and off by the utility. Do not operate this appliance by means of an external timer or separate remote-control system.



CAUTION: HOT SURFACES.

The temperature of accessible surfaces are hot when the appliance is operating. Always use oven mitt to protect hand when moving heating and cooking plates and ring assemblies.

SAVE THESE INSTRUCTIONS!

Other Consumer Safety Information

This product is intended for household use only.

The length of the cord used on this appliance was selected to reduce the hazards of becoming tangled in or tripping over a longer cord. If a longer cord is necessary, an approved extension cord may be used. The electrical rating of the extension cord must be equal to or greater than the rating of the appliance. Care must be taken to arrange the extension cord so that it will not drape over the countertop or tabletop where it can be pulled on by children

or accidentally tripped over.

To avoid an electrical circuit overload, do not use another high-wattage appliance on the same circuit with this appliance.

Parts and Features

BEFORE FIRST USE: Lift cover to remove each ring assembly. Wash both rings in dishwasher or in hot, soapy water. Rinse and dry. Wipe top and bottom heating plates with a damp, soapy cloth. Remove soap with a damp cloth; dry thoroughly. Spray rings with nonstick cooking spray or wipe or brush with vegetable oil.

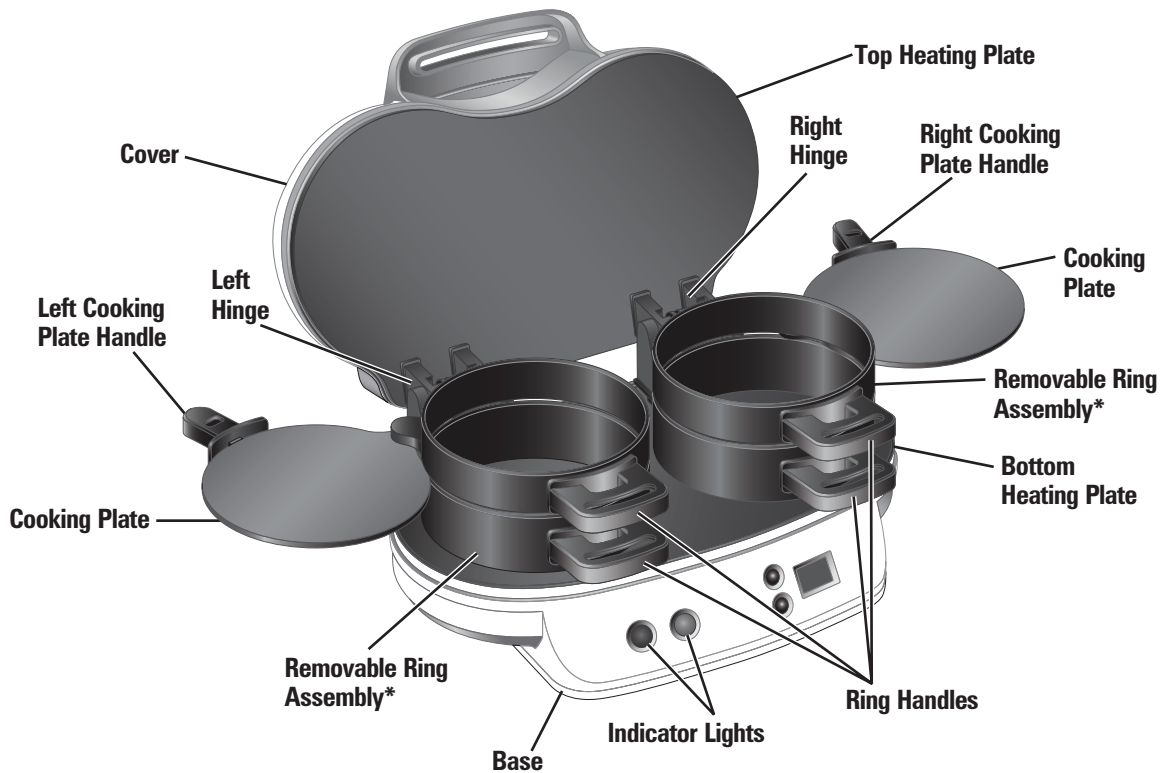

Indicator Lights

POWER



Red POWER Light

PREHEAT



Green PREHEAT Light

Up Button



Down Button

Timer



How to Use

This sandwich maker makes one or two sandwiches at the same time.

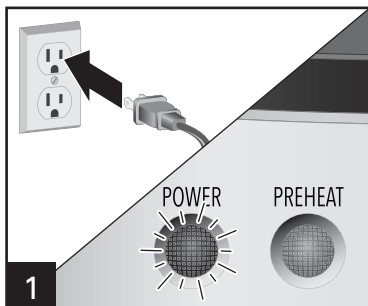

Plug cord into wall outlet. The red **POWER** light will glow. Lightly spray rings with nonstick cooking spray if necessary.

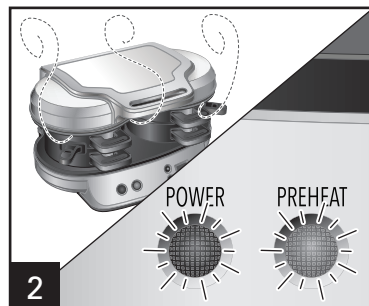

Let unit preheat with cover closed and cooking plates rotated in between rings.

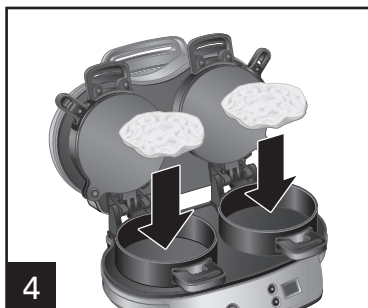

Place bottom half of bread (such as an English muffin, small bagel, or biscuit) onto bottom plates.

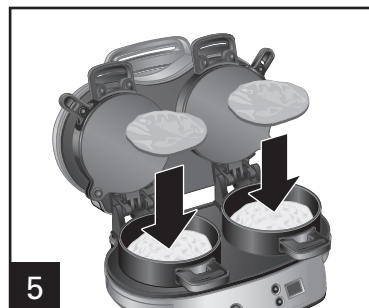

Top bread with ingredients such as precooked meats, vegetables, and cheese. Do not overfill breakfast sandwich maker. Overfilling will cause food to spill over rings and get stuck in the hinges. Move top rings and cooking plates down. Make sure cooking plates are rotated securely to back of rings as far as they will go to prevent leaking of egg.

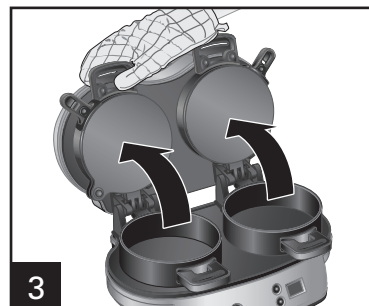
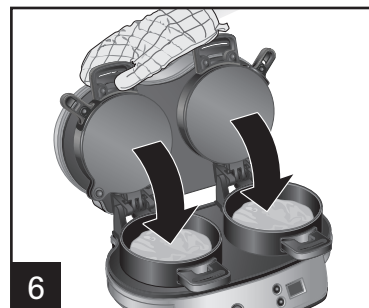

Use handles to lift cover, top rings, and cooking plates.

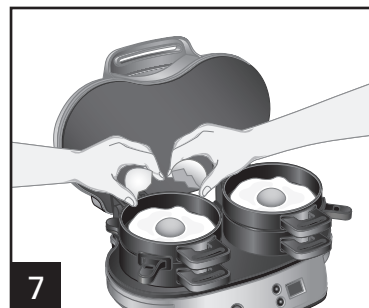

Crack an egg onto each cooking plate. Pierce yolk with a fork or toothpick. (You can use a whole large egg, egg white, or a scrambled egg.)

⚠ WARNING Burn Hazard.

Always use an oven mitt to protect hand when opening cover. Hot surfaces and escaping steam can burn.

NOTE: Green **PREHEAT** light will come on when unit is heated to the correct temperature and will cycle on and off during cooking. It is **NOT** an indicator when sandwich is ready. Red **POWER** light stays on.

How to Use (cont.)



Top with the other half of bread. Close cover. Cook sandwiches for around 5 minutes. **NOTE:** Do not push lid all the way down when loaded with ingredients or when using jumbo eggs. Lid may rise as scrambled eggs cook.



Press the up or down button to the desired time in half-minute (0.5) increments. If the up or down button has not been pressed in 5 seconds, the timer will start. When there is less than 1 minute remaining, the timer switches to seconds and continues to count down.

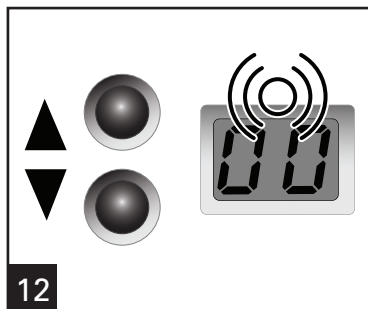
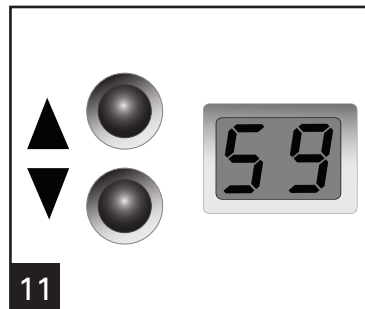

The timer will beep when the time is up. This unit does not turn off automatically at the beep.

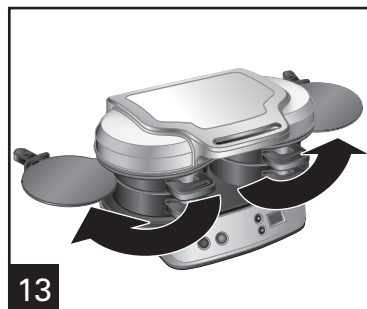

When finished cooking, rotate cooking plate handles out until they stop.

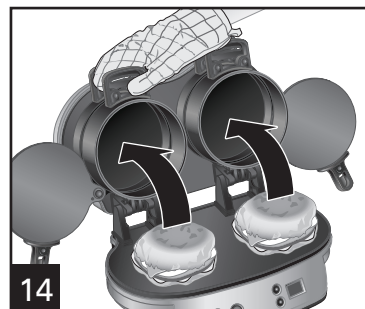

Using an oven mitt, lift ring assemblies and cover by holding bottom ring handles to open. Some sandwiches are easier to remove if rings are lifted individually.

How to Use (cont.)

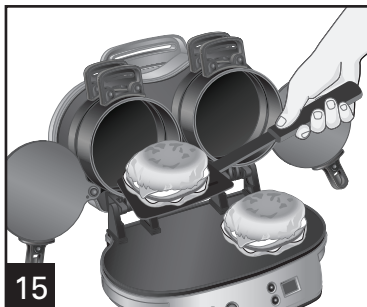

Remove breakfast sandwiches with plastic or wooden utensil. Never use metal.

Always wait 2 minutes between cooking sandwiches to ensure the breakfast sandwich maker is heated to the correct temperature.

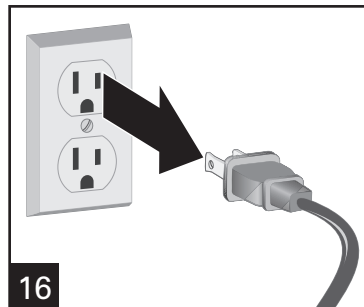

Unplug when through cooking. Let cool.

TIPS:

- Get your ingredients together before cooking your sandwiches.
- Always keep cover closed with rings and cooking plates in place when preheating.
- Check to make sure the cooking plates are in place before preheating and when adding food.

Care and Cleaning

⚠ WARNING Electrical Shock Hazard.

Disconnect power before cleaning. Do not immerse cord, plug, or base in any liquid.

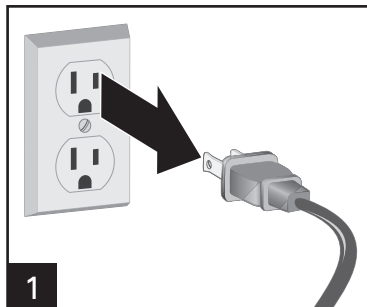

1 Unplug unit when through cooking. Let cool.

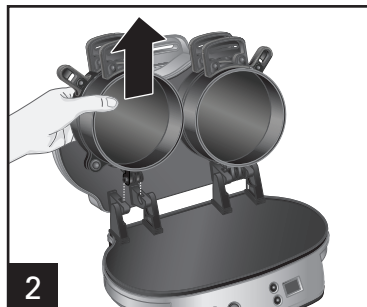

2 To remove ring assembly for cleaning, hold bottom handle to open, and then lift straight up.

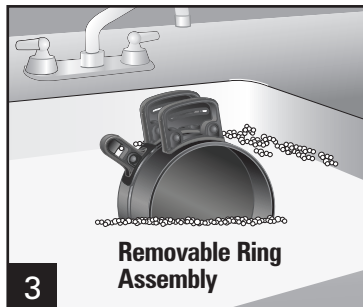

3 Do not use steel wool, scouring pads, or abrasive cleansers on any part of the unit. Never use sharp or pointed objects for cleaning.



**TOP-RACK
DISHWASHER-SAFE**

DO NOT use the "SANI" setting when washing in the dishwasher. "SANI" cycle temperatures could damage your product.

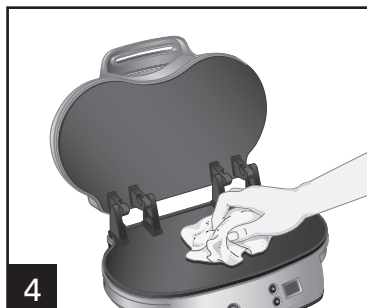

4 Wipe top and bottom heating plates with a damp, soapy cloth. Remove soap with a damp cloth; dry thoroughly.

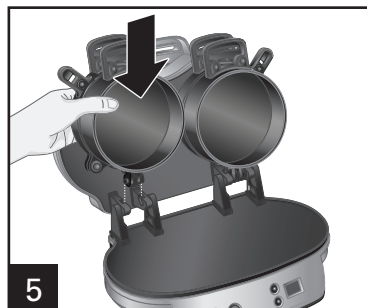

5 To replace ring assemblies, align hinges to the base, taller ring on the bottom, with the cooking plate handles facing out, and lower.

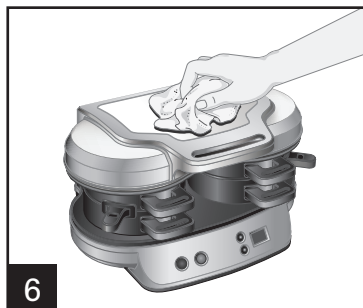

6 Wipe outside of unit with a damp, soapy cloth.

NOTE: If ring assemblies are not correctly replaced, the cover won't close properly.

Troubleshooting

PROBLEM	PROBABLE CAUSE/SOLUTION
Low, poor, or slow heating.	<ul style="list-style-type: none">• Breakfast sandwich maker wasn't preheated until PREHEAT light was illuminated. Green PREHEAT light will come on in about 2 to 4 minutes indicating unit is heated to the correct temperature. Light will cycle and does not indicate sandwich is ready.• Allow 2 minutes between making sandwiches for breakfast sandwich maker to heat to the correct temperature.• Overfilled. Reduce amount of ingredients in your sandwich.• Unit needs to be preheated with the cover closed with rings and cooking plate in place.• Make sure cooking plate is rotated securely to back of ring as far as it will go, to prevent leaking of egg, and cover is closed when preheating.
Egg undercooked, bread not done.	<ul style="list-style-type: none">• Extra large eggs, frozen, or very cold ingredients may lengthen cooking time. Add additional cooking time.
Egg overcooked.	<ul style="list-style-type: none">• Cooking time is about 5 minutes. Cooking time may vary if you are using small eggs, scrambled or egg whites. Reduce cooking time for future recipes.
Ingredients stick to rings or nonstick cooking plate.	<ul style="list-style-type: none">• Use a plastic or wooden utensil to loosen any baked-on ingredients. Lightly spray with nonstick cooking spray before preheating for next use.
Eggs leak out of rings.	<ul style="list-style-type: none">• Unit is overfilled. Only use large eggs and reduce amount or size of ingredients. Do not press down on the cover.• Cooking plate may not have been in the correct position. Make sure cooking plate is rotated securely to back of ring as far as it will go to prevent leaking of egg.• Used very thin purchased egg whites. Use fresh egg white or try a different brand of egg whites.• Make sure unit is properly preheated.
Cover rises when cooking my sandwich.	<ul style="list-style-type: none">• The air whisked into a large scrambled egg may cause the cover to rise while the egg is cooking. Do not press down on the cover.
Bread too brown.	<ul style="list-style-type: none">• Higher fat contents and sugars may cause breads to darken. Cook eggs for several minutes without top bread and cover down. Also have ingredients ready to assemble so bottom bread does not cook a lot longer than top ingredients. Then add bread to finish cooking your sandwiches.

Recipes

Egg, Ham, and Cheese Breakfast Sandwich

2 English muffins, split
2 slices American cheese
2 slices precooked Canadian bacon or ham
2 large eggs

Directions

1. Preheat Dual Breakfast Sandwich Maker until green **PREHEAT** light comes on. Lift cover, top rings, and cooking plates.
2. Place half of muffin, split-side up, in each bottom ring of Dual Breakfast Sandwich Maker. Top with cheese and Canadian bacon.
3. Lower cooking plates and top rings. Add an egg to each cooking plate. Pierce yolks with a fork or toothpick.
4. Top with remaining muffin halves, split-side down.
5. Close cover. Cook around 5 minutes. Rotate cooking plate handles out until they stop. Lift cover and rings and carefully remove sandwiches with plastic spatula.

Serves: 2

Pancakes and Sausage Sandwich

4 (4-inch) frozen pancakes
2 precooked thin sausage patties
2 large eggs
Maple syrup

Directions

1. Preheat Dual Breakfast Sandwich Maker until green **PREHEAT** light comes on. Lift cover, top rings, and cooking plates.
2. Place one frozen pancake in each bottom ring of Dual Breakfast Sandwich Maker. Top with sausage.
3. Lower cooking plates and top rings. Add an egg to each cooking plate. Pierce yolks with a fork or toothpick.
4. Top with remaining pancakes.
5. Close cover. Cook around 5 minutes. Rotate cooking plate handles out until they stop. Lift cover and rings and carefully remove sandwiches with plastic spatula. Serve with syrup.

Serves: 2

Recipes (cont.)

Cheddar, Apple, Bacon, and Egg Croissant Sandwich

2 small croissants, halved
4 Tablespoons (59 ml) shredded Cheddar cheese
8 thin slices Granny Smith apple
2 slices precooked bacon, cut in half
2 large eggs

Directions

1. Preheat Dual Breakfast Sandwich Maker until green **PREHEAT** light comes on. Lift cover, top rings, and cooking plates.
2. Place half of croissant, cut-side up, in each bottom ring of Dual Breakfast Sandwich Maker. Top with cheese, apple slices, and bacon.
3. Lower cooking plates and top rings. Add an egg to each cooking plate. Pierce yolks with a fork or toothpick.
4. Top with remaining croissant halves, cut-side down.
5. Close cover. Cook around 5 minutes. Rotate cooking plate handles out until they stop. Lift cover and rings and carefully remove sandwiches with plastic spatula.

Serves: 2

Southwestern Breakfast Muffin

2 whole wheat English muffins, split
2 slices Monterey Jack cheese
6 thin slices avocado
2 large egg whites
2 Tablespoons (30 ml) salsa

Directions

1. Preheat Dual Breakfast Sandwich Maker until green **PREHEAT** light comes on. Lift cover, top rings, and cooking plates.
2. Place half of muffin, split-side up, in each bottom ring of Dual Breakfast Sandwich Maker. Top with cheese and avocado.
3. Lower cooking plates and top rings. Add egg white to each cooking plate.
4. Top with remaining muffin halves, split-side down.
5. Close cover. Cook around 5 minutes. Rotate cooking plate handles out until they stop. Lift cover and rings and carefully remove sandwiches with plastic spatula. Serve with salsa.

Serves: 2

Recipes (cont.)

Cheesy Egg and Sausage Bagel

2 small bagels, halved
2 slices Jarlsberg cheese
2 precooked thin sausage patties
2 thin slices red pepper ring
2 large eggs

Directions

1. Preheat Dual Breakfast Sandwich Maker until green **PREHEAT** light comes on. Lift cover, top rings, and cooking plates.
2. Place half of bagel, split-side up, in each bottom ring of Dual Breakfast Sandwich Maker. Top with cheese, sausage, and red pepper ring.
3. Lower cooking plates and top rings. Add an egg to each cooking plate. Pierce yolks with a fork or toothpick.
4. Top with remaining bagel halves, split-side down.
5. Close cover. Cook around 5 minutes. Rotate cooking plate handles out until they stop. Lift cover and rings and carefully remove sandwiches with plastic spatula.

Serves: 2

Herb Goat Cheese, Spinach, and Tomato Egg Muffin

2 whole wheat English muffins, split
2 Tablespoons (30 ml) herb goat cheese
2 thin slices tomato
8 spinach leaves
2 thin slices red pepper ring
2 large eggs white

Directions

1. Preheat Dual Breakfast Sandwich Maker until green **PREHEAT** light comes on. Spread goat cheese over bottom half of muffins. Lift cover, top rings, and cooking plates.
2. Place halves of muffin, goat cheese side up, in bottom of Dual Breakfast Sandwich Maker. Top with tomato, spinach, and red pepper ring.
3. Lower cooking plates and top rings. Add egg white to each cooking plate.
4. Top with remaining muffin halves, split-side down.
5. Close cover. Cook around 5 minutes. Rotate cooking plate handles out until they stop. Lift cover and rings and carefully remove sandwiches with plastic spatula.

Serves: 2

重要安全说明

当使用电器时，应始终遵守基本的安全防范措施，以减少火灾、触电和/或人身伤害的风险，包括以下内容：

1. 阅读所有相关说明。
2. 本电器不适合以下人群（包括儿童）使用、清洁或维护：行动不便者、精神或智商缺陷者、缺少经验和常识者，除非他们在监督和指导上使用，以确保安全。请勿将本电器用于儿童玩耍。
3. 在未受监督下儿童不可以执行清洁和用户维护工作。
4. 请勿接触发热表面。应使用手柄或旋钮。
5. 为防止触电危险，请勿将电源线、插头或烹饪组件放入水或其他液体中。
6. 当电器不使用或清洁前，请从插座拔下电源。安装、拆解部件和清洁前，请先将其冷却。
7. 在下列情况下，请勿使用电器：电源线或插头破损、电器出现故障、电器曾跌落或已经出现任何形式的损坏。请拨打我们的免费售后服务电话，咨询有关电器检查、修理或调整的相关信息。如果电源软线损坏，为了避免危险，必须由制造商、其维修部或类似部门的专业人员更换。
8. 使用非本电器制造商推荐的配套附件可能会导致受伤。
9. 请勿户外使用。
10. 请勿将电源线搭置在桌台边缘上或与发热表面接触，包括电炉。
11. 请勿靠近或放置在燃气或电炉上，或放进加热烤箱内。
12. 请勿将电器用于非预期用途。
13. 请勿在无人看护时使用电器。
14. 使用过程中，在上方、后面和两侧需保持4至6英寸（10-15厘米）的空间，便于空气流通。
15. 切勿使用任何类型的切刀或其他金属厨房用具取出食物。
16. 收藏本电器时，务必让其冷却，在电器仍较热时，切勿将电源线缠绕在电器周围。
17. **注意：**为了避免由于热熔断器的疏忽重置导致的危险，本电器不能在外接定时器或独立的遥控控制系统的方式下运行。
本电器不可用通过外部定时器或单独的遥控系统进行操作。
 **注意：高温表面。**
当本电器工作时，可触及的外部表面温度会很高。移动加热和烤盘以及锅圈组件时，务必戴上烤箱手套保护双手。

请妥善保管这些说明！

其他用户安全信息

本产品建议于家庭使用。

此电器电源线的长度设计考虑减少长电源线缠绕或绊倒的危险。倘若需要更长的电源线，可使用有认证的电源延长线。电源延长线的额定功率必须等于或大

于此电器的额定功率。电源延长线使用时需特别注意，以防将其搭设在工作台或桌面上，造成儿童扯拉或绊倒他人。

为防止电路过载，请勿在此电器的同一电路上使用其他高功率电器。

部件和功能

首次使用前：提起上盖，取出锅圈组件。在洗碗机或在带清洁剂的温水中清洗两个可拆卸的锅圈组件。冲洗，然后晾干。用带清洁剂的湿布擦拭顶部和底部加热板。用干净的湿布擦拭干净，彻底晾干。在锅圈上喷上食用油，或刷上植物油。

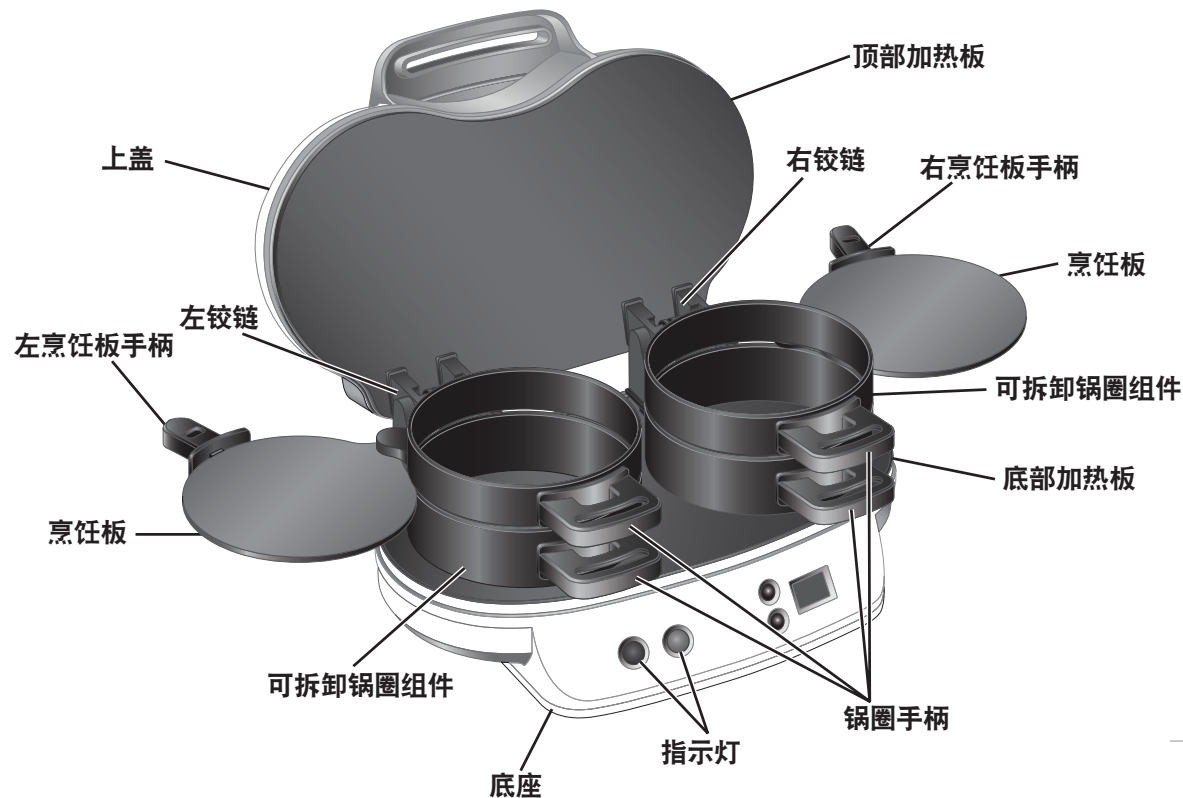

指示灯

电源



红色电源
指示灯

预热



绿色预热
指示灯

向上按钮



定时器

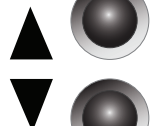

向下按钮

如何使用

此款早餐机可同时制作一个或两个三明治。

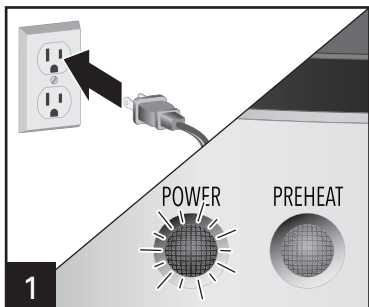

1 将电源线插入墙上的电源插座。红色电源指示灯将点亮。必要时，在锅圈上轻轻喷一层食用油。

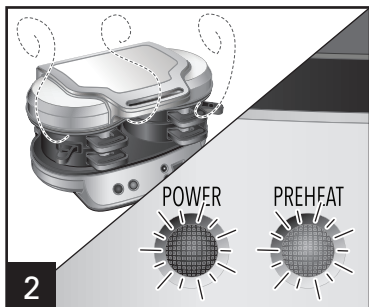

2 旋转烹饪板，使其处在两个锅圈之间，合上上盖，让机器预热。

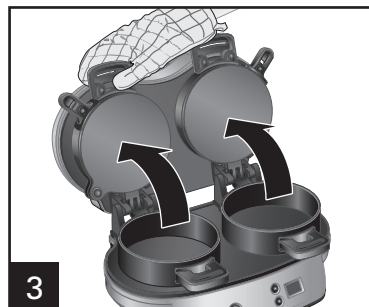

3 使用手套掀起上盖、顶部锅圈和烹饪板。

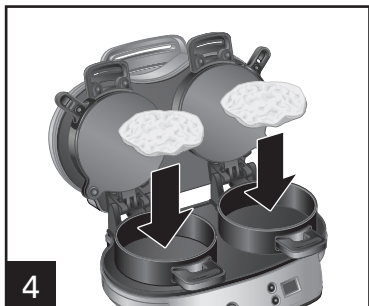

4 将底部的半片面包（如英式松饼、小面包圈或饼）放至底板上。

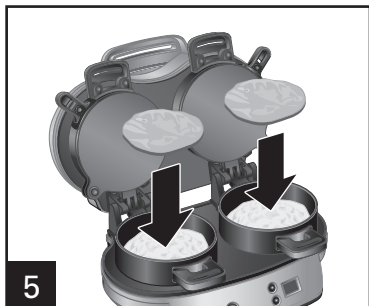

5 在面包上添加预制的肉类、蔬菜和奶酪。请勿在三明治早餐机中添加过多食材。添加过多可能导致食物从锅圈中溢出，并会卡在铰链中。将顶部锅圈和烹饪板放下。注意：请确保烹饪板完全放置在两个锅圈之间，防止蛋液漏出。

警告 烫伤危险。
操作上盖时务必戴上烤箱手套保护手。热表面和漏出的蒸汽可能会导致烫伤。

注意：当本电器加热至一定的温度时，绿色预热指示灯将点亮，并且在烹饪过程中，该指示灯将循环点亮和熄灭。在此过程中，红色电源指示灯始终保持点亮状态。

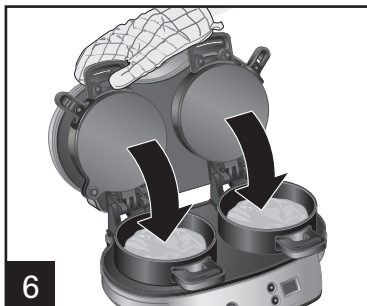

7 将鸡蛋打在每个烹饪板上。用叉子或牙签刺穿蛋黄。（您可以使用整个生鸡蛋、蛋清或打散的蛋液。）

如何使用 (续)

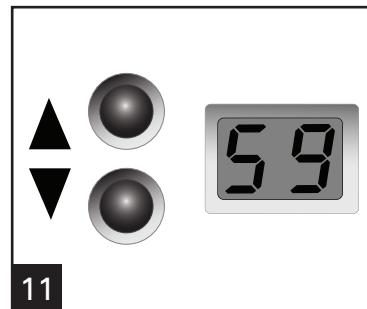

在上面添加另外半片面包。合上上盖。烹饪约5分钟即可。**注意：**当食材过多或鸡蛋太大时，请勿用力将盖子按下。使用打散的蛋液烹饪时，盖子可能会稍微升起。

按向上或向下按钮以半分钟（0.5）为单位的增量调节所需的时间。如果5秒钟内未再按向上或向下按钮，定时器将开始计时。当倒计时进入一分钟时，定时器将会以秒为单位进行显示，持续倒数计时。

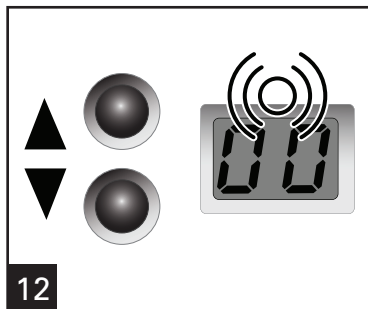

当计时结束，定时器将发出蜂鸣音。此时早餐机并不会自动关机。

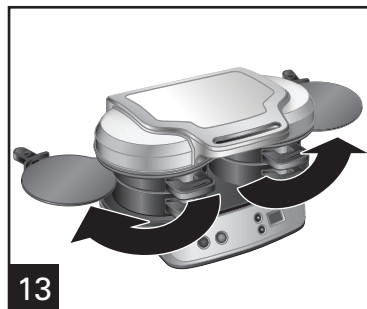

烹饪完成后，旋转烹饪板手柄到各自可停止的位置。

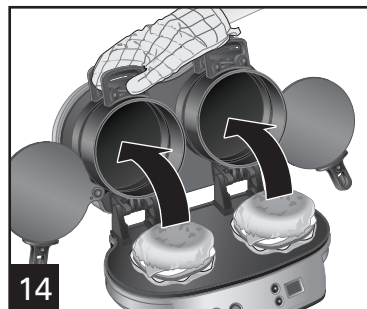

戴上手套，固定好底座，握住下锅圈的手柄，掀起锅圈组件和上盖。如单个逐步提起上盖和上下锅圈，汉堡更容易取出。

如何使用 (续)

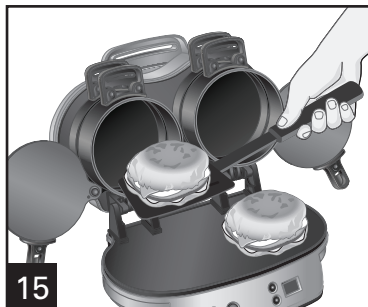

烹饪两次汉堡之间，务必等待2分钟，以确保早餐机加热至合适的温度。

用塑料或木制器具取出汉堡。切勿使用金属器具。

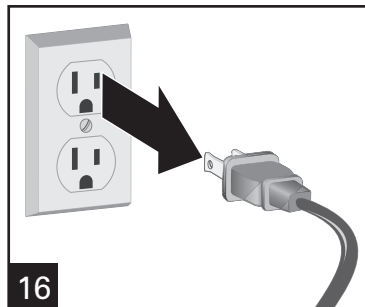

烹饪完成后拔掉插头。让电器冷却。

提示:

- 烹饪前，将所有食材准备好。
- 预热时，确保上盖合上，锅圈和烹饪板处于正确的位置。
- 添加食物前，检查并确保烹饪板处于正确的位置。

保养与清洗

警告 电击危险。
清洁前断开电源。请勿将电源线、插头或底座浸在任何液体中。

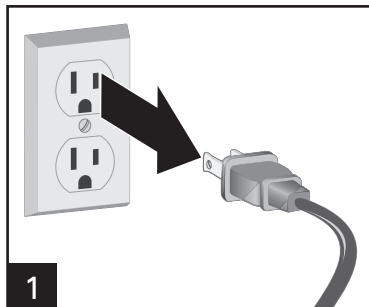

烹饪完成后拔掉插头，让电器冷却。

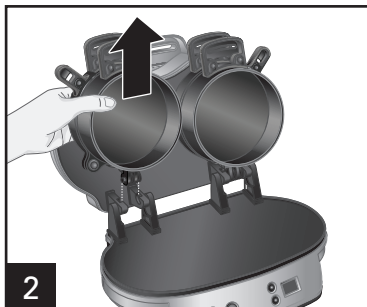

若要卸下锅圈组件进行清洁，确保上下锅圈在合并状态下，然后垂直向上提起。



请勿使用钢丝球、百洁布或磨蚀性清洁剂擦拭装置的任何部分。切勿使用锋利或尖锐的物体进行清洁。



在洗碗机中清洗时，请勿使用“SANI”设置。“SANI”循环温度会损坏本产品。

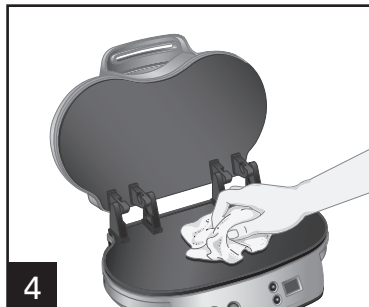

用带清洁剂的湿布擦拭顶部和底部加热板。用干净的湿布擦拭干净，彻底晾干。

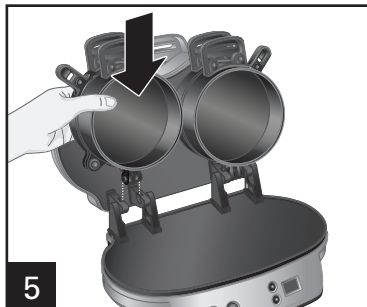

安装锅圈组件时，将铰链与底座对齐，上锅圈在下锅圈上方，让烹饪板手柄朝外，然后放下固定好。

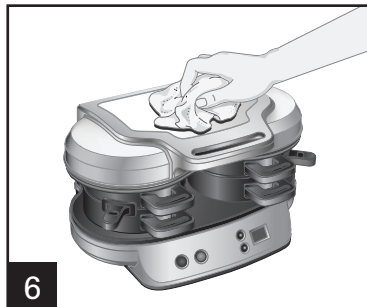

用带清洁剂的湿布擦拭装置的外部。

注意：如果未正确安装锅圈组件，上盖可能盖不住。

故障排除

问题

可能的原因/解决方案

加热温度低、加热不好或加热慢。

- 早餐机未预热。绿色**预热**指示灯点亮约需2至4分钟，表示电器已加热到一定的温度。指示灯循环点亮和熄灭，并不表示三明治已做好。
- 制作两次三明治之间，等待2分钟，让机器加热至合适的温度。
- 加入过多食材。减少三明治中的食材量。
- 电器须在上盖合上和烹饪板处于原位的状态下预热。
- 确保上盖合上，烹饪板处于锅圈正确的位置，防止蛋液漏出。

蛋未煮熟，面包未做好。

- 超大鸡蛋、冷冻或极冷的食材可能会延长烹饪时间。增加额外的烹饪时间。

蛋糊了。

- 烹饪时间约5分钟。如果您使用小鸡蛋、打散的蛋液或蛋清，烹饪时间可能会有所不同。减少烹饪时间。

食材粘在锅圈上或不粘烹饪板上。

- 用塑料或木制器具弄开粘上的食材。下次使用时，预热前，在锅圈上喷一层食用油。

蛋液从锅圈中漏出。

- 加入了过多食材。使用大鸡蛋时，减少食材的量或大小，请勿用力按下上盖。
- 烹饪板可能未处于正确的位置。确保烹饪板和上下锅圈保持合并状态，防止蛋液漏出。
- 购买较稀薄蛋清。使用新鲜蛋清或尝试不同品牌的蛋清。
- 请确保对本机进行适当预热。

烹饪汉堡时上盖升起。

- 打散的蛋液中有空气气泡，可能导致烹饪时上盖微微上升，请勿用力按下上盖。

面包烤焦。

- 较高脂肪和糖含量的面包可能会易烤焦。可先将鸡蛋烹饪几分钟后，此时上层面包和上盖不要盖上。或者先准备好要添加的食材，不要让下层的面包比上层的面包烤的时间长。再加入面包来完成烹饪。

食谱

火腿芝士蛋汉堡

2个汉堡面包，分别分成两半
2片芝士
2片培根或火腿
2个鸡蛋

制作方法：

1. 将双盘早餐机进行预热，直到绿色**预热**指示灯点亮。提起上盖、上锅圈和烹饪板。
2. 将半片汉堡面包，分开面朝上，放入双盘早餐机的每个下锅圈中，在上面添加芝士和火腿。
3. 放下烹饪板和上锅圈，把蛋打在烹饪板上，用叉子或牙签刺穿蛋黄。
4. 在上面添加剩余的半块汉堡面包，分开面朝下。
5. 合上上盖，烹饪约5分钟。顺时针旋转烹饪板手柄到停止的位置，提起上盖和锅圈，小心地用塑料铲取出汉堡。

份量：2份

香肠烧饼汉堡

4个（4英寸）冷冻烧饼
2个预煮薄香肠肉饼
2个鸡蛋
枫糖酱

制作方法：

1. 将双盘早餐机进行预热，直到绿色**预热**指示灯点亮。提起上盖、上锅圈和烹饪板。
2. 将一个冷冻煎饼放入双盘早餐机的每个下锅圈中，在上面添加香肠。
3. 放下烹饪板和上锅圈，把蛋打在烹饪板上，用叉子或牙签刺穿蛋黄。
4. 在上面添加另一块烧饼。
5. 合上上盖，烹饪约5分钟。顺时针旋转烹饪板手柄到停止的位置，提起上盖和锅圈，小心地用塑料铲取出汉堡，涂上糖浆。

份量：2份

食谱（续）

切达干酪、苹果、培根、鸡蛋和羊角面包汉堡

- 2个小羊角面包，分别分成两半
- 4汤匙（59毫升）切碎的切达奶酪
- 8薄片苹果
- 2片预煮培根，分别切成两半
- 2个鸡蛋

制作方法：

1. 将双盘早餐机进行预热，直到绿色**预热**指示灯点亮。提起上盖、上锅圈和烹饪板。
2. 将一半羊角面包，切开面朝上，放入双盘早餐机的每个下锅圈中，在上面添加奶酪、苹果片和培根。
3. 放下烹饪板和上锅圈，把蛋打在烹饪板上，用叉子或牙签刺穿蛋黄。
4. 在上面添加剩余的半块羊角面包，切开面朝下。
5. 合上上盖，烹饪约5分钟。顺时针旋转烹饪板手柄到停止的位置，提起上盖和锅圈，小心地用塑料铲取出汉堡。

份量：2份

西南早餐汉堡

- 2个全麦英式汉堡面包，分别分成两半
- 2片蒙特里杰克奶酪
- 6薄片鳄梨
- 2份鸡蛋清
- 2汤匙（30毫升）洋葱番茄辣酱

制作方法：

1. 将双盘早餐机进行预热，直到绿色**预热**指示灯点亮。提起上盖、上锅圈和烹饪板。
2. 将半片汉堡面包，分开面朝上，放入双盘早餐机的每个下锅圈中，在上面添加奶酪和鳄梨。
3. 放下烹饪板和上锅圈，将蛋清加在烹饪板上。
4. 在上面添加剩余的半块汉堡面包，分开面朝下。
5. 合上上盖，烹饪约5分钟。顺时针旋转烹饪板手柄到停止的位置，提起上盖和锅圈，小心地用塑料铲取出汉堡。涂上洋葱番茄辣酱。

份量：2份

食谱 (续)

干酪蛋和香肠面包圈

- 2个小面包圈，分别分成两半
- 2片片亚尔斯堡奶酪
- 2个预煮薄香肠肉饼
- 2薄片红辣椒圈
- 2个鸡蛋

制作方法：

1. 将双盘早餐机进行预热，直到绿色**预热**指示灯点亮。提起上盖、上锅圈和烹饪板。
2. 将一半面包圈，分开面朝上，放入双盘早餐机的每个下锅圈中，在上面添加奶酪、香肠和红辣椒圈。
3. 放下烹饪板和上锅圈，把蛋打在烹饪板上，用叉子或牙签刺穿蛋黄。
4. 在上面添加剩余的半块面包圈，分开面朝下。
5. 合上上盖，烹饪约5分钟。顺时针旋转烹饪板手柄到停止的位置，提起上盖和锅圈，小心地用塑料铲取出汉堡。

份量：2份

草山羊奶酪、菠菜、番茄鸡蛋松饼

- 2个全麦英式汉堡面包，分别分成两半
- 2汤匙（30毫升）草山羊奶酪
- 2薄片番茄
- 8片菠菜叶
- 2薄片红辣椒圈
- 2份鸡蛋清

制作方法：

1. 将双盘早餐机进行预热，直到绿色**预热**指示灯点亮。将山羊奶酪涂在松饼的下半部分。提起上盖、上锅圈和烹饪板。
2. 将半片松饼，涂有山羊奶酪的面朝上，放入双盘早餐机的每个下锅圈中，在上面添加西红柿、菠菜和红辣椒圈。
3. 放下烹饪板和上锅圈，将蛋清加在烹饪板上。
4. 在上面添加剩余的半块汉堡面包，分开面朝下。
5. 合上上盖，烹饪约5分钟。顺时针旋转烹饪板手柄到停止的位置，提起上盖和锅圈，小心地用塑料铲取出汉堡。

份量：2份

产品中有害物质的名称及含量
Name and content of hazardous substances in product

部件名称 (Component name)	有害物质(hazardous substance)					
	铅 Lead (Pb)	汞 Mercury (Hg)	镉 Cadmium (Cd)	六价铬 Hexavalent Chromium (Cr(VI))	多溴联苯 Polybrominated biphenyls (PBB)	多溴二苯醚 Polybrominated diphenyl ethers (PBDE)
线路板 (PCB ASSY)	X	O	O	O	O	O

本表格依据 SJ/T 11364 的规定编制。

This table is prepared in accordance with the provisions of SJ/T 11364.

O: 表示该有害物质在该部件所有均质材料中的含量均在 GB/T 26572 规定的限量要求以下。

Indicates that the said hazardous substance contained in all the homogeneous materials for this component is below the limit requirement in GB/T 26572.

X: 表示该有害物质至少在该部件的某一均质材料中的含量超出 GB/T 26572 规定的限量要求。这是由于目前技术或经济等的原因暂时无法实现替代。

Indicates that the said hazardous substance contained in at least one of the homogeneous materials used for this component is above the limit requirement in GB/T 26572.

Due to technological and/ or economic reasons, these hazardous substances cannot be easily replaced at this time.



这是环保使用标志。标志内的数字代表在正常使用状态下，产品的环保使用推荐年限。

This is the logo of environmental protection use. The number inside indicates the environmental protection use recommended period (Year) of product in normal use.

Model/型号:
25490-CN

Type/类别:
ST30

Rating/规格:
220V~ 50Hz 1000W

Dist.: Hamilton Beach Brands, Inc., Glen Allen, VA 23060
© 2016 Hamilton Beach Brands, Inc.

以上内容如有改动，恕不预先通知



添加官方微博 微信
开启美食人生

840273900