

**READ BEFORE USE**

**使用前阅读**

Visit [www.hamiltonbeach.cn](http://www.hamiltonbeach.cn) for our complete line of products and Use and Care Guides – as well as delicious recipes, tips, and to register your product online!

有关我们所有系列产品的，使用与维护指南 – 以及美味食谱、生活小贴士和产品在线注册的更多信息，请访问 [www.hamiltonbeach.cn](http://www.hamiltonbeach.cn)。

**Questions?**

**Please call us – our friendly associates are ready to help.  
China: 400-852-2655**

**如有疑问？  
请致电我们，我们的团队随时准备为您提供帮助。  
中国大陆客服热线：  
400-852-2655  
官方网站：[www.hamiltonbeach.cn](http://www.hamiltonbeach.cn)**

**型号：33999-CN**

**此说明书中图片仅供参考，  
产品以实物为准。**

**使用产品前请仔细阅读本使用说明书，  
并妥善保管。**



# Stovetop-Safe Programmable American Cooker 美式炖锅



English (Original) ..... 2  
简体中文 ..... 11

# IMPORTANT SAFEGUARDS

When using electrical appliances, basic safety precautions should always be followed to reduce the risk of fire, electric shock, and/or injury to persons, including the following:

1. Read all instructions.
2. Do not touch  hot surfaces. Use handles or knobs with oven mitts when cooking as they may be hot.
3. To protect against electric shock, do not immerse cord, plug, or base in water or other liquid.
4. This appliance is not intended for use by persons (including children) with reduced physical, sensory, or mental capabilities, or lack of experience and knowledge, unless they are closely supervised and instructed concerning use of the appliance by a person responsible for their safety.
5. Unplug from outlet when not in use and before cleaning. Allow to cool before putting on or taking off parts.
6. Do not operate any appliance with a damaged cord or plug, or after the appliance malfunctions or is dropped or damaged in any manner. Call our customer service number for information on examination, repair, or adjustment. If the supply cord is damaged, it must be replaced by the manufacturer, its service agent or similarly qualified persons in order to avoid a hazard.
7. The use of accessory attachments not recommended by the appliance manufacturer may cause injuries.
8. Do not use outdoors.
9. Do not let cord hang over edge of table or counter, or touch hot surfaces, including stove.
10. Do not place base on or near a hot gas or electric burner or in a heated oven.
11. Extreme caution must be used when moving an appliance containing hot oil or other hot liquids.
12. To disconnect American cooker, turn control knob to OFF (●); then remove plug from wall outlet.
13. **CAUTION:** To prevent damage or shock hazard, do not cook in base. Cook only in removable stovetop-safe cookware.
14. Avoid sudden temperature changes, such as adding refrigerated foods into heated stovetop-safe cookware.
15. Do not use appliance for other than intended use.
16. **CAUTION:** In order to avoid a hazard due to inadvertent resetting of the thermal cut-out, this appliance must not be supplied through an external switching device, such as a timer, or connected to a circuit that is regularly switched on and off by the utility.

## SAVE THESE INSTRUCTIONS

### OTHER CONSUMER SAFETY INFORMATION

**This product is intended for household use only.**

This product is only intended for the preparation, cooking, and serving of foods. This product is not intended for use with any non-food materials or products.

**WARNING!** Shock Hazard: Do not defeat the safety purpose of the plug by modifying the plug in any way or by using an adapter. If the plug does not fit fully into the outlet, reverse the plug. If it still does not fit, have an electrician replace the outlet.

The length of the cord used on this appliance was selected to reduce the hazards of becoming tangled in or tripping over a longer cord. If a longer cord is necessary, an approved extension cord may be used. The electrical rating of the extension cord must be equal to or greater than the rating of the appliance. Care must be taken to arrange the extension cord so that it will not drape over the countertop or tabletop where it can be pulled on by children or accidentally tripped over.

## GLASS LID AND STOVETOP-SAFE COOKWARE: PRECAUTIONS AND INFORMATION

- Please handle lid and stovetop-safe cookware carefully to ensure long life.
- Avoid sudden, extreme temperature changes to the lid. For example, do not place a hot lid into cold water or onto a wet surface.
- Avoid hitting lid against faucet or other hard surfaces.
- Do not use lid if chipped, cracked, or severely scratched.
- Do not use abrasive cleansers or metal scouring pads.
- The stovetop-safe cookware is ovenproof. The lid is not ovenproof.
- Never heat stovetop-safe cookware when empty.
- Never place lid or stovetop-safe cookware in microwave oven or toaster oven.
- Never place lid directly on a burner or stovetop.
- Never use lid or stovetop-safe cookware under a broiler.

## REMOVING GLASS LID AND STOVETOP-SAFE COOKWARE

When removing lid, tilt so that opening faces away from you to avoid being burned by steam.

The lid handles, base, and stovetop-safe cookware, as well as the sides of American cooker base, all become very warm during cooking. Always use oven mitts when handling **ANY** part of the American cooker during cooking.

CAUTION: HOT SURFACE. The temperature of accessible surface may be high when the appliance is operating.

# Specifications

Model No.	Power	Capacity	Low Setting Power	High Setting Power	Keep Warm Power
33999-CN	AC220V~, 50Hz	5.5L	290W (discontinuous power)	290W	290W (discontinuous power)

# Parts and Features

## Stovetop-Safe Cookware Capacity

For best results, fill the stovetop-safe cookware at least half full but no more than one inch from the rim. If only half-filled, check for doneness 1 to 2 hours earlier than recipe time.

### Lid Vent Hole

**NOTE:** The purpose of the lid vent hole is to vent steam. Cooking time is not affected. Do not remove silicone gasket from hole.

Glass Lid

Cast-Aluminum  
Stovetop-Safe  
Cookware

Base

Base Handles

Keep Warm Low

Off High

Control Knob/Display

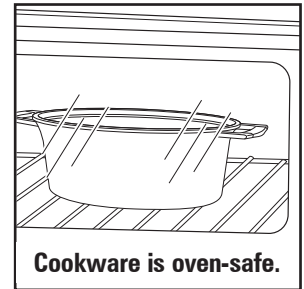

**CAUTION: HOT SURFACE.**

The temperature of accessible surface may be high when the appliance is operating

# How to Sear in Stovetop-Safe Cookware

**BEFORE FIRST USE:** Wash lid and stovetop-safe cookware in hot, soapy water. Rinse and dry.

**NOTE:** Do not use metal utensils when placing food in and removing food from stovetop-safe cookware.

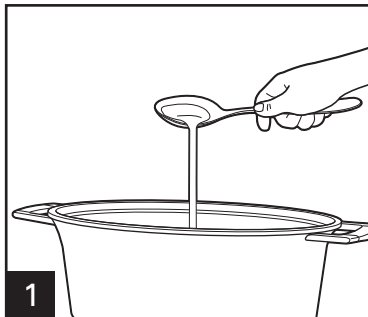

1 Add oil to stovetop-safe cookware.

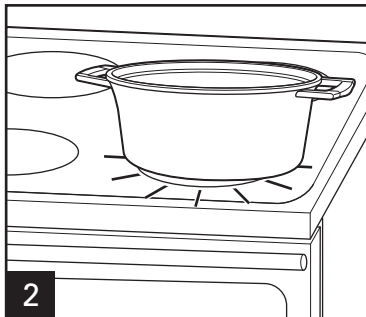

2 Heat oil on stovetop over medium to high heat.

**NOTICE:** Do not heat stovetop-safe cookware when empty since cooking surface and/or stovetop-safe cookware may be damaged.

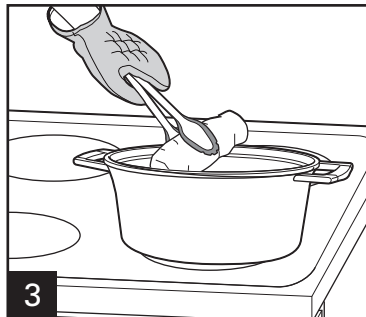

3 Place food to be seared into stovetop-safe cookware.

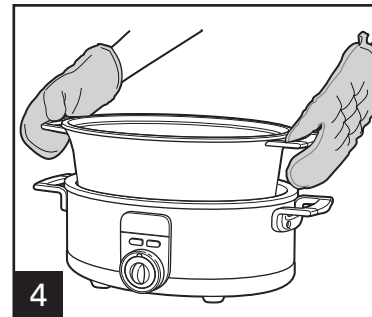

4 When finished searing, follow recipe or carefully place stovetop-safe cookware in base. Proceed to "How to Slow Cook" section.

# How to Slow Cook

**BEFORE FIRST USE:** Wash lid and stovetop-safe cookware in hot, soapy water. Rinse and dry.

## NOTES:

- Do not use metal utensils when placing food in and removing food from stovetop-safe cookware.
- Display does not show any text other than "Err" and "OFF." When control knob is set, display will show set cook time and the cooking LED light blinks before cooking starts. After cooking starts, display will show remaining cook time and the cooking LED light will remain lit.

**⚠ WARNING Food Safety Hazard.** Food must be hot enough to prevent bacterial growth before using WARM setting. The WARM setting should only be used after a recipe has been thoroughly cooked. Do not reheat food on WARM setting. If food has been cooked and then refrigerated, reheat it on LOW or HIGH and then switch to WARM.

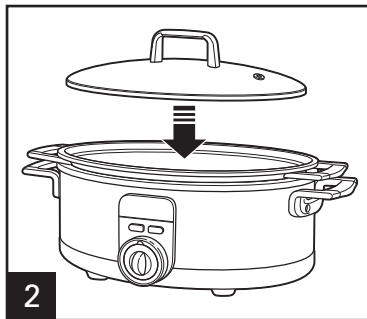
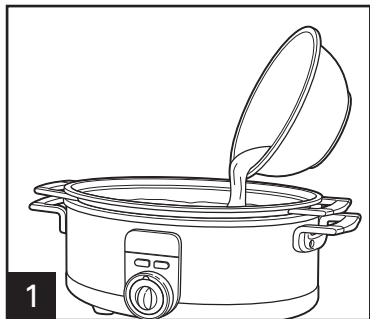

**NOTE:** Lid vent hole will not affect cooking time.

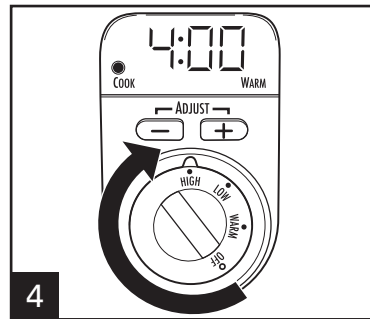
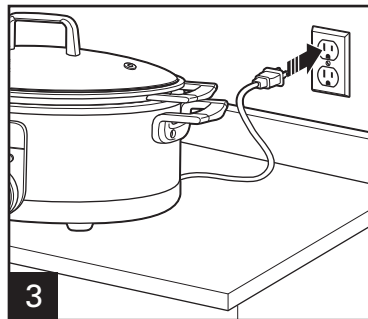

Turn control knob to desired heat setting to cook. Do not cook on WARM.

**NOTE:** Display will show default cook time.

# How to Slow Cook (cont.)

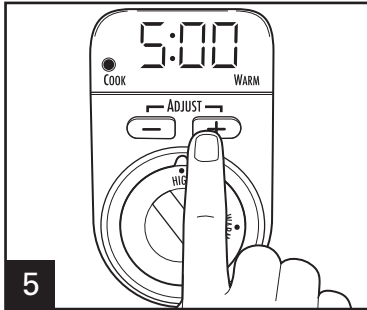

5 Press the + or – buttons to select desired cooking time.

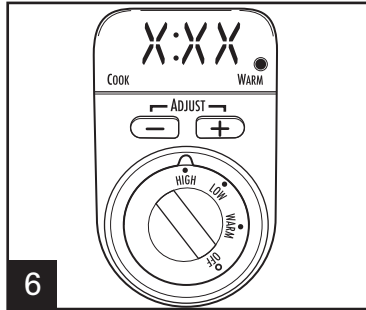

6 At the end of cooking time, the American cooker will automatically switch to WARM setting, but the knob will NOT automatically rotate to WARM.

**NOTE:** Cook time plus warm time cannot exceed 14 hours. When the unit switches to WARM, the display (X:XX) will show how much time is remaining of the 14 hours.

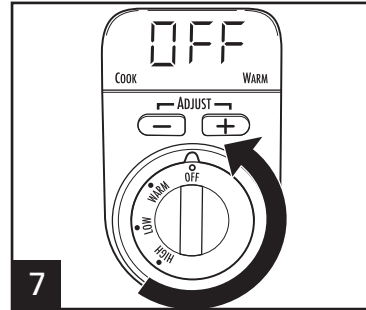

7 **NOTE:** The American cooker will automatically shut OFF if left on for a total of 14 hours. The unit will be OFF, the display will show “OFF,” but the control knob will NOT turn to OFF/O.

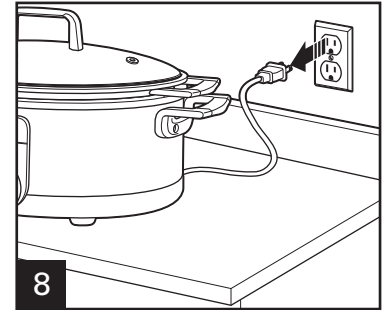

8

# Care and Cleaning



**WARNING**

**Electrical Shock Hazard.**

Disconnect power before cleaning.

Do not immerse cord, plug, or base in any liquid.

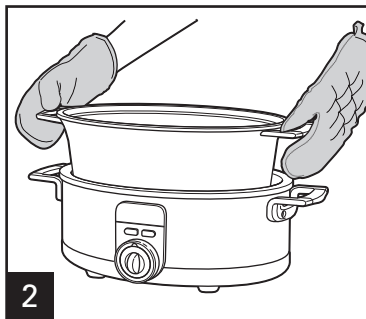
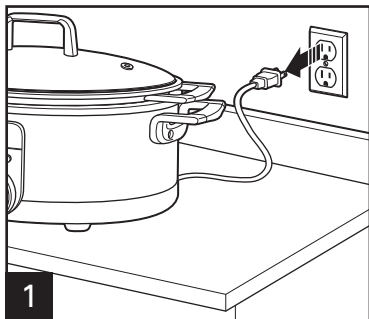

Remove stovetop-safe cookware and let cool.

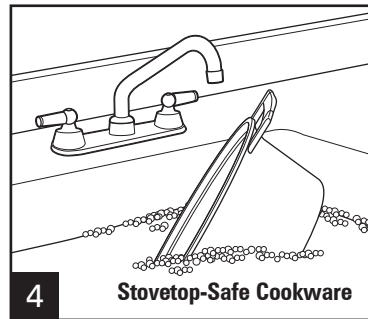
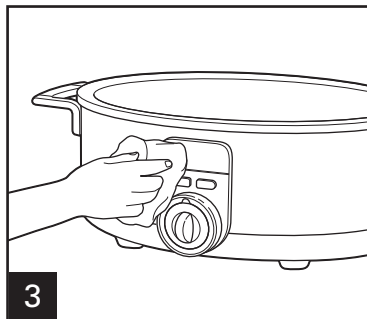

**Stovetop-Safe Cookware**

Wash stovetop-safe cookware in hot, soapy water.

**NOTICE:** Do not use metal utensils or abrasive cleansers when cleaning stovetop-safe cookware's nonstick surface.

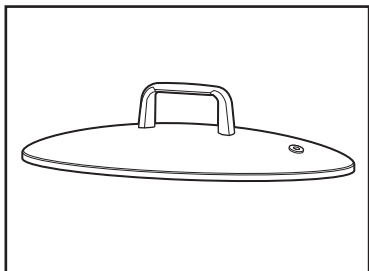

**DISHWASHER-SAFE**

DO NOT use the "SANI" setting when washing in the dishwasher. "SANI" cycle temperatures could damage your product.



# Tips for Slow Cooking

- The stovetop-safe cookware should be at least half-filled for best results. If only half-filled, check for doneness 1 to 2 hours earlier than recipe time.
- Stirring is not necessary when slow cooking. Removing glass lid results in major heat loss and the cooking time may need to be extended. However, if cooking on HIGH, you may want to stir occasionally.
- If cooking soups or stews, leave a 2-inch (5-cm) space between the top of the stovetop-safe cookware and the food so that the recipe can come to a simmer.
- Many recipes call for cooking all day. If your morning schedule doesn't allow time to prepare a recipe, do it the night before. Place all ingredients in stovetop-safe cookware, cover with lid, and refrigerate overnight. In the morning, simply place stovetop-safe cookware in American cooker.
- Some foods are not suited for extended cooking in a American cooker. Pasta, seafood, milk, cream, or sour cream should be added 2 hours before serving. Evaporated milk or condensed soups are perfect for slow cooking.
- The higher the fat content of meat, the less liquid is needed. If cooking meat with a high fat content, place thick onion slices underneath so meat will not sit on (and cook in) fat.
- American cooker allow for very little evaporation. If making your favorite soup, stew, or sauce, reduce liquid called for in original recipe. If too thick, liquid can be added later.
- If cooking a vegetable-type casserole, there will need to be liquid in the recipe to prevent scorching on the sides of stovetop-safe cookware.
- If cooking a recipe with root vegetables, place root vegetables in the bottom of the stovetop-safe cookware.

# Food Safety Tips

- Do not use frozen, uncooked meat in the American cooker. Thaw any meat or poultry before slow cooking.
- To store leftovers after cooking, do NOT place the stovetop-safe cookware in the refrigerator since contents will take too long to cool. Instead, divide leftovers into smaller containers and place into refrigerator.
- Never allow undercooked or raw meat to sit at room temperature in the American cooker. Once meat is placed into the stovetop-safe cookware, it should be cooked immediately (unless prepping American cooker the night before, where stovetop-safe cookware should be placed into the refrigerator).

# Troubleshooting

PROBLEM	PROBABLE CAUSE
Food is undercooked.	<ul style="list-style-type: none"><li>• Was food cooked on the Warm setting? Do not cook on Warm; always cook on Low or High heat settings.</li><li>• Was power interrupted?</li><li>• Did you select the Low heat setting but used a cooking time based on the High heat setting?</li><li>• Did you have the lid placed correctly on the American cooker?</li></ul>
The food isn't done after cooking the amount of time recommended in my recipe.	<ul style="list-style-type: none"><li>• This can be due to voltage variations (which are commonplace everywhere) or altitude. The slight fluctuations in power do not have a noticeable effect on most appliances. However, they can alter cooking times in the American cooker by extending the cooking times. Allow sufficient time and select the appropriate heat setting. You will learn through experience if a shorter or longer time is needed. <b>NOTE:</b> Lid vent hole will not affect cooking time.</li></ul>
My meal was overcooked. Why?	<ul style="list-style-type: none"><li>• Was the stovetop-safe cookware at least half full? The American cooker has been designed to thoroughly cook food in filled stovetop-safe cookware. If the stovetop-safe cookware is only half-filled, check for doneness 1 to 2 hours earlier than recipe time.</li><li>• Did you select correct number of hours based on cooking temperature (Low or High)?</li><li>• Foods will continue to increase in temperature after desired temperature has been reached.</li><li>• Was the stovetop-safe cookware used to brown foods on the stovetop and placed in base while still hot? If so, cooking time may be shortened. Check for doneness 30 minutes to 1 hour earlier than recipe time.</li></ul>
Display shows "Err" and food is not cooked.	<ul style="list-style-type: none"><li>• Was power interrupted during cooking (due to brownout, electrical storm, etc.)? Please check if food is still safe to prepare and eat; then turn the control knob or press any button. The American cooker will turn ON.</li></ul>

# 重要安全说明

当使用带电设备时，为降低火灾、电击风险以及对个人造成的伤害，请注意基本的安全预防措施，具体如下：

1. 阅读所有说明。
2. 请勿接触设备  热表面，请使用把手或者旋钮。
3. 为防止电击危险，请勿将设备的线缆、插头、或底座浸入水或其他液体中。
4. 本电器不适合以下人群（包括儿童）使用：行动不便者、精神或智商缺陷者、缺少经验和常识者，除非他们在监护人的密切监督和指导下使用，以确保安全。
5. 在设备不工作时及清理前，请从插座中拔出插头，待设备冷却后，方能增加或移除部件。
6. 请勿使用任何损坏的线缆或插头操作设备、或在设备故障、跌落或因任何方式损坏后使用。请拨打我们的客户服务电话以获取检查、修理或调整的相关信息。如果电源软线损坏，为了避免危险，必须由制造商、其维修部或类似部门的专业人员更换。
7. 使用非本产品制造商推荐的配套附件有可能造成危害。
8. 请勿在室外使用。
9. 请勿将电源线缆悬挂在桌子或柜台边缘，或接触包括炉子在内的热表面。
10. 请勿将设备放置于热燃气、电炉、热烤箱之上或附近。
11. 当设备内盛有热油或其他热液体时，在移动设备时更需格外谨慎。
12. 如果要断开美式炖锅电源，请将控制旋钮转至关（OFF）档并将插头从插座中拔出。
13. **注意：**为防止危害或电击，请勿使用底座直接烹饪，仅在可移动内胆内烹饪。
14. 避免突然的温度改变，如将冷冻食物放入已加热的内胆中。
15. 请勿将设备作设计外功能使用。
16. **小心：**为了避免由于热熔断器的意外重置导致的危险，本电器不能在外接定时器或独立的摇控控制系统的方式下运行。

## 请妥善保管说明书！

## 其他用户安全信息

### 此设备仅供家庭使用。

此设备仅用于食物的准备、烹饪及服务。此设备不能使用非食物类的材料和产品。

**警告！电击危险：**此设备带有地线插头以降低电击危险。

此插头仅适用于地线插座。请勿以任何方式改造此插头或使用转换接头，而使其丧失安全功能。如果插头无法插入，请尝试翻转插头。如果仍然无法插入，请找电工更换插座。

此设备使用的电源线缆长度经过设计挑选，以降低线缆缠结或过长导致误绊的危害。如需使用更长的线缆，可使用经过认可的加长线缆，加长线缆的电性能需等同或优于此美式炖锅的电性能。加长线缆需谨慎安置以免其挂于橱面或桌面而因此可能被儿童拉扯或导致误绊。

## 可火烧式铸铝内胆及盖子：预防措施及信息

- 请小心使用内胆和盖子，以保证长使用寿命。
  - 避免突然或极端的温度改变。例如，请勿将灼热内胆或盖子置于冷水中，或放置于潮湿的表面上。
  - 避免内胆或盖子与水龙头或其他硬表面发生碰撞。
  - 如内胆或盖子缺损、开裂或严重刮伤时，请勿使用。
  - 请勿使用具有腐蚀作用的清洁剂和金属清洁用品。
- 可火烧式铸铝内胆可放入烤箱，盖子则不可以。
  - 请勿空烧铸铝内胆。
  - 请勿将盖子和铸铝内胆放入微波炉或面包烤炉内。
  - 请勿将盖子直接放在电炉或燃气炉上。
  - 请勿将盖子和铸铝内胆放在烈日下暴晒。

## 移走玻璃盖和铸铝内胆

移走玻璃盖时，适度倾斜远离打开锅面以避免蒸汽烫伤。

玻璃盖把手，底座、铸铝内胆以及底座侧面会在美式炖锅工作时变得非常灼热。在美式炖锅工作时如需接触其任何部分都应使用隔热手套。

# 产品规格

型号	电源	容量	低温功率	高温功率	保温功率
33999-CN	AC220V~, 50Hz	5.5升	290W (电源间断开启)	290W	290W (电源间断开启)

# 部件及特征

## 内胆容积

为保证最佳烹饪效果，请至少将内胆装至半满，但不能超过内胆口2.5厘米。如果内胆仅半满，请比原定食谱时间提前一到两小时检查食物煮熟程度。

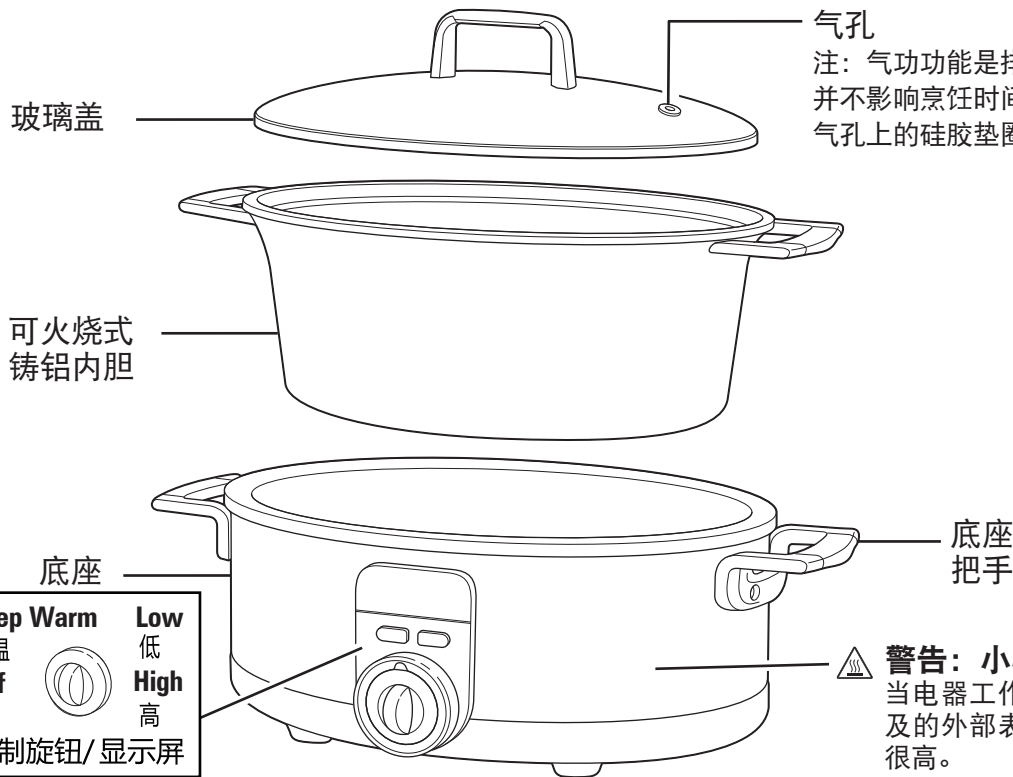

注：气功能是排放热蒸汽，并不影响烹饪时间。请勿将气孔上的硅胶垫圈移除。

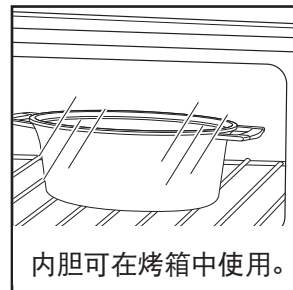

**警告：小心烫伤！**  
当电器工作时，可触及的外部表面温度会很高。

# 如何使用您的美式炖锅

**第一次使用前：** 请用热肥皂水清洗玻璃盖和内胆，清洗后弄干。

注：在将食物放入或移出内胆时，请勿使用金属器皿。

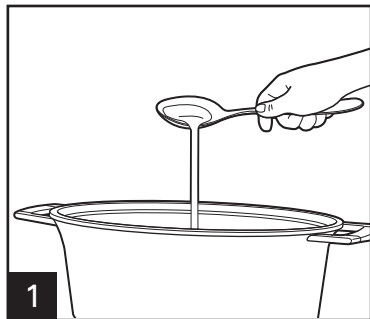

1 在内胆中放入油。

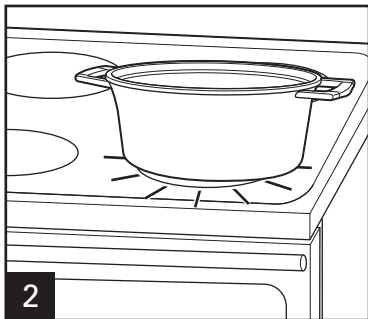

2 在火炉上将油加热至中高温。  
注：请勿空烧内胆，否则有可能将其损坏。

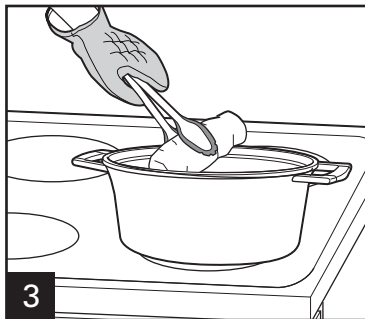

3 将要油煎的食物放入内胆中。

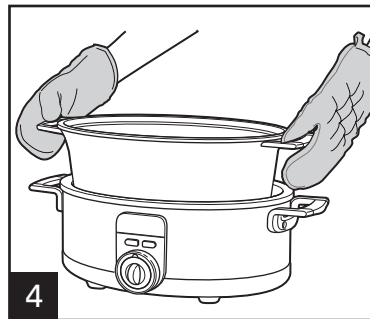

4 食物煎好后，按照食谱流程或将内胆小心放入底座。按照“如何慢炖”流程操作。

# 如何慢炖

## 警告

**食品安全危害：**在使用保温档时，食物应当彻底热透以防细菌滋生。只有在食材被彻底烹饪后，方能使用保温档。请勿使用保温档再次加热食物。如果食物已经被煮熟或者冷藏过，请用高/低两档重新加热后再使用保温档。

**第一次使用前：**请用热肥皂水清洗玻璃盖和内胆，清洗后弄干。

注：

- 在将食物放入或移出内胆时，请勿使用金属器皿。
- 显示屏只会显示“错误”(ERR)或“关”(OFF)字样。当旋转控制旋钮设定烹饪后，显示屏会显示设定的烹饪时间，且在烹饪开始前LED灯会闪烁。烹饪开始后，显示屏会显示剩余烹饪时间，且LED指示灯会常亮。

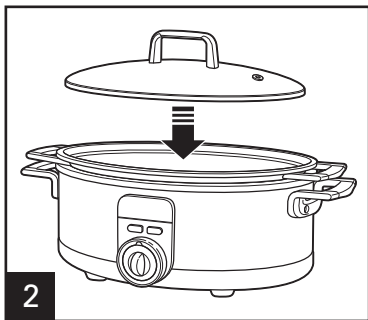
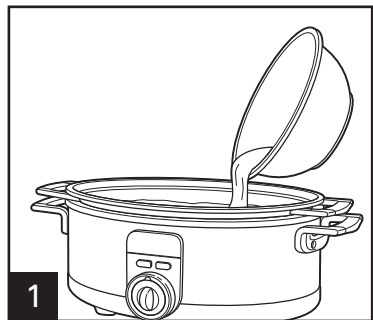

注：玻璃盖气孔不会影响烹饪时间。

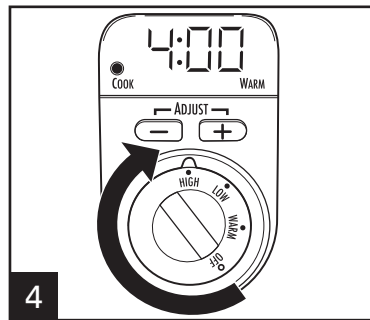
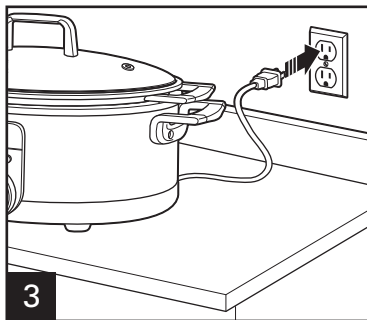

将旋钮拧至你想要的温度设定档来烹饪。请勿使用保温(WARM)档烹饪。  
注：显示屏将显示默认的烹饪时间。

# 如何慢炖 (续)

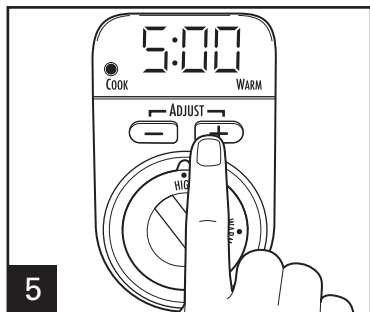

5 按 + 或 - 按钮设定想要的烹饪时间。

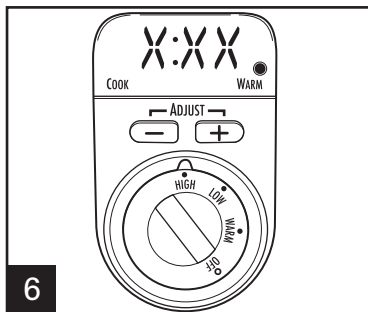

6 设定的烹饪时间结束后，美式炖锅会自动切换到保温 (WARM) 档，但控制旋钮不会自动转回保温 (WARM) 档。  
注：烹饪时间加上保温时间不能超过14小时。当设备自动切换到保温 (WARM) 档时，显示屏 (X:XX) 将会显示此14小时中剩下的时间。

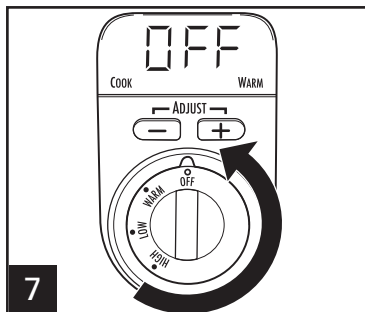

7 注：美式炖锅无人看管工作14小时后将会自动关闭。设备关闭后，显示屏会显示“关闭” (OFF)，但控制旋钮不会自动转回“关闭” (OFF/●) 档。

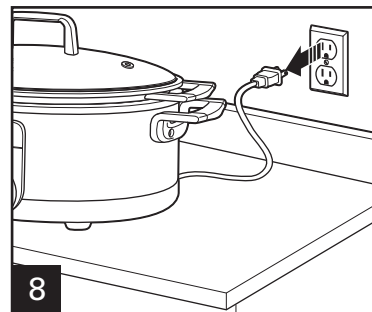



# 妥善放置及清理

⚠ 警告

**电击危险。**

在清理前请断开电源。请勿将电源线、插头或底座浸入任何液体中。

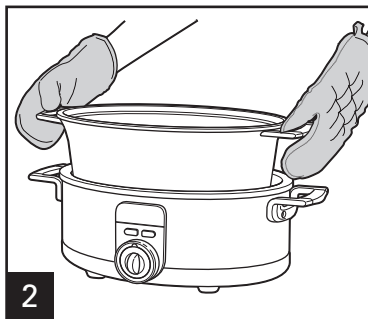
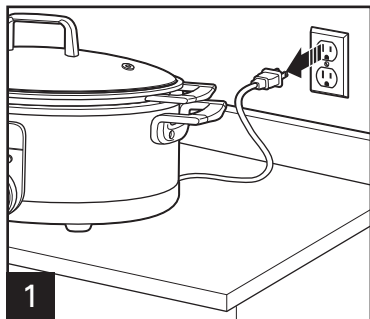

取出内胆并让其自然冷却。

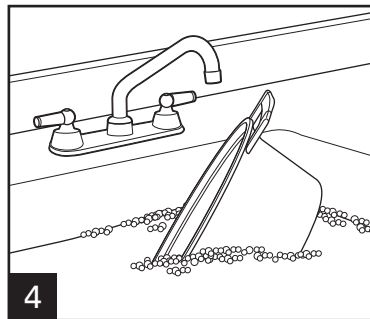
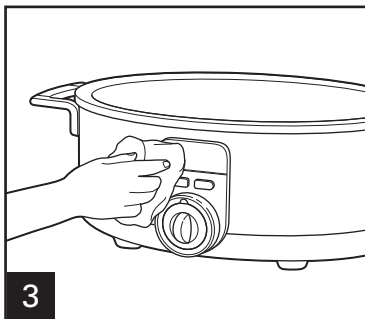

用热肥皂水清洗内胆。

注意：请勿使用金属器皿或具有腐蚀作用的清洁剂来清洗内胆的不粘表面。

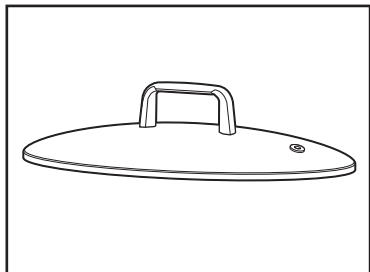

**玻璃盖可机洗**

在洗碗机中清洗玻璃盖时请勿使用消毒档，此档位的循环温度可能会损坏本产品。

# 慢炖贴士

- 内胆中至少要装满一半食物方能达到最佳烹饪效果。当内胆中只装满一半时，请按照食谱时间提前1至2小时检查食物煮熟程度。
- 慢炖食物时不需要搅拌，打开玻璃盖会造成大量热量损失，因此可能会导致烹饪时间加长。尽管如此，当在高(High)档烹饪时，可以适当偶尔搅拌食物。
- 在烹饪汤或者炖菜时，请在内胆顶部与食材之间留出5厘米的空间以便能够徐沸食材。
- 许多食谱需要烹饪一整天。如果你早上无瑕准备食谱，可在前夜准备。将所有食材放入内胆盖上盖子整夜冷藏，第二天早上只需将内胆放入美式炖锅中烹饪即可。
- 有些食物不适宜在美式炖锅中长时间烹饪。意大利面、海鲜、牛奶、奶油或者酸奶油应在上菜前2小时加入美式炖锅。脱水牛奶或者浓缩汤最适合美式炖锅烹饪。
- 肉类的脂肪含量越高，慢炖时需要的水越少。若慢炖的肉脂肪含量很高，可在底部放些厚洋葱片，这样可防止油煎。
- 美式炖锅基本没有蒸发效果。若烹饪汤、炖菜或酱类食物，可根据原始食谱规定的液量稍作减少。若液量较大，可稍后添加。
- 若烹饪蔬菜类砂锅，食谱中应包含液体以避免内胆侧烧焦食材。
- 若食材内包含根茎类蔬菜，请将其放在内胆底部。

# 食物安全提示

- 请勿在美式炖锅中放入冷冻或未煮过的肉。任何肉类和禽类都需在慢炖前解冻。
- 为在烹饪结束后保存剩菜，请不要将整个内胆直接放入冰箱，否则内胆需要很长时间才能冷却。请将剩菜分开放入小的容器后再放入冰箱冷藏。
- 请勿将未经烹饪的原材料肉类在室温下放在内胆中存放。肉类在放入内胆后应当立即开始烹饪（除非在前夜为准备第二天的慢炖用，而将食材放入内胆中并放进冰箱冷藏）。

# 故障排除

## 故障现象

炖出的食物半生不熟。

用菜谱建议的烹饪时间没有炖好食物。

为什么食物会煮过头？

显示“错误”(ERR)且食物没有被烹饪好。

## 可能原因

- 是不是保温档炖的食物？请勿使用保温档烹饪，只用高温或低温档烹饪。
- 电源是否中断过？
- 您是不是选择了低温档，但是按照高温档设定的时间烹饪的？
- 玻璃盖是否正确盖在美式炖锅上？

- 可能因电压不稳(在各地都常见)或海拔的缘故。此类电源起伏变化对大多数电器影响并不显著。然而，此种现象会影响美式炖锅的烹饪时间。低于额定的电压将需要更长时间来烹饪，反之高于额定电压则需时较短。具体请根据您的实际使用经验调整。  
注：玻璃盖气孔不会影响烹饪时间。

- 内胆是否至少半满？此美式炖锅设计用于彻底煮熟满锅食物。若内胆中半满，请将食谱时间提前1至2小时检查食物煮熟程度。
- 根据烹饪温度(高温或低温)您是否正确选择了烹饪时间？
- 达到需求温度后，食物温度仍然会持续上升。
- 在内胆煎完食物后是否在其仍然很烫时就放入底座？这样的话烹饪时间应当缩短。请将食谱时间提前半小时到一小时。
- 在烹饪中电源是否中断(因限电、雷雨等原因)？请先检查食物是否仍然能够食用，然后转动控制旋钮或按任意键，设备将会启动。

以上内容如有改动，恕不预先通知。

注意

注意

## 食品接触材料信息



本产品符合相应食品安全国家标准要求，食品接触用材料及其执行标准的符合性信息说明如下：

序号	部件名称	材质	执行标准	备注
1	玻璃盖塑胶垫片	聚丙烯(PP)	GB4806.1-2016;GB4806.7-2016	*
2	铝压铸锅不粘涂层	聚四氟乙烯(PTFE)	GB4806.1-2016;GB4806.7-2016	*
3	玻璃盖密封硅胶圈	聚二甲基硅氧烷(硅橡胶)	GB4806.1-2016;GB4806.11-2016	*
4	玻璃盖透气孔垫	聚二甲基硅氧烷(硅橡胶)	GB4806.1-2016;GB4806.11-2016	*
5	玻璃盖不锈钢大圆头螺钉	不锈钢 06Cr18Ni11Ti (SUS321)	GB4806.1-2016;GB4806.9-2016	*
6	玻璃盖不锈钢包边	不锈钢 06Cr19Ni10 (SUS304)	GB4806.1-2016;GB4806.9-2016	*
7	玻璃盖	玻璃	GB4806.1-2016;GB4806.5-2016	*

注：1. 特殊使用说明：请严格遵照说明书及产品所带附件资料使用本产品。

2. \*表示：该部件仅适用于部分型号，具体以实际产品为准。

产品中有害物质的名称及含量  
Name and content of hazardous substances in product

部件名称 (Component name)	有害物质(hazardous substance)					
	铅 Lead (Pb)	汞 Mercury (Hg)	镉 Cadmium (Cd)	六价铬 Hexavalent Chromium (Cr(VI))	多溴联苯 Polybrominated biphenyls (PBB)	多溴二苯醚 Polybrominated diphenyl ethers (PBDE)
Control PCBA 控制面板	X	0	0	0	0	0
Power PCBA 电源板	X	0	0	0	0	0

本表格依据 SJ/T 11364 的规定编制。 This table is prepared in accordance with the provisions of SJ/T 11364.

O: 表示该有害物质在该部件所有均质材料中的含量均在 GB/T 26572 规定的限量要求以下。

Indicates that the said hazardous substance contained in all the homogeneous materials for this component is below the limit requirement in GB/T26572.

X: 表示该有害物质至少在该部件的某一均质材料中的含量超出 GB/T 26572 规定的限量要求。这是由于目前技术或经济等的原因暂时无法实现替代或减量化。

Indicates that the said hazardous substance contained in at least one of the homogeneous materials used for this component is above the limit requirement in GB/T 26572. Due to technological and/ or economic reasons, these hazardous substances cannot be easily replaced at this time.



这是环保使用标志. 标志内的数字代表在正常使用状态下, 产品的环保使用推荐年限。

This is the logo of environmental protection use. The number inside indicates the environmental protection use recommended period (Year) of product in normal use.

**Model/型号:**  
33999-CN

**Type/类别:**  
SC42

**Capacity/容积:**  
5.5L

**Rating/规格:**  
220V~ 50Hz 290W

制造商：汉密尔顿海滩电器（深圳）有限公司  
地址：深圳市福田区深南西路车公庙工业区天安数码时代大厦主楼 1306-1308、1309-1311 单元  
本产品执行标准：GB4706.1-2005, GB4706.19-2008

以上内容如有改动，恕不预先通知



添加官方微博 微信  
开启美食人生