

Microwave Oven

Owner's Manual



Safety Information.....

2

- Welcome...2
- Grounding...4
- Excessive Energy Warning...5
- Features and Benefits, Specifications...6



Operating your microwave.....

8

- Setting up your microwave...8
- Parts and Accessories...8
- Turntable Installation...8
- Control Panel...9
- Power Levels...10
- Clock...10
- One Stage Cooking...10
- Two Stage Cooking...11
- Defrost...11-12
- Clock Function...14
- Child Lock...14
- Kitchen Timer...14



One-touch buttons.....

11

- Add 30 Seconds...11
- Express Cooking...11
- Popcorn...12
- Potato...12
- Pizza...12
- Beverage...13
- Soup...13
- Dinner Plate...13
- Fresh Vegetable...13
- Frozen Vegetable...14



Use and Care.....

15

- Care and Cleaning...15
- Troubleshooting...16
- Warranty...17
- Technical Support...17
- Ordering Parts...17



Welcome!

Congratulations, you have acquired a high quality Proctor Silex™ Microwave Oven. This unit is packed with many extra features that you will find convenient to use. Six express cook and eight different one-touch cooking buttons provide for convenient meal preparation and tasty snacks. It will provide you with many years of trouble free use if you follow the safety precautions and operating instructions provided in this easy-to-use manual. Please take the time to read it, and save these instructions for future use. Please also remember to record the series code. This is found on label on back of the unit. Save your receipt by stapling it to this manual for convenient access.

Model number: **87025** Series code _____ Date of purchase _____

!! IMPORTANT SAFETY INSTRUCTIONS !!

When using electrical appliances, basic safety precautions should be followed, including the following:

WARNING! - To reduce the risk of burns, electric shock, fire, injury to persons, or exposure to excessive microwave energy:

- 1) Read all instructions before using the appliance.
- 2) Read and follow the specific "PRECAUTIONS TO AVOID POSSIBLE EXPOSURE TO EXCESSIVE MICROWAVE ENERGY" found on page 5.
- 3) This appliance must be grounded. Connect only to properly grounded outlet. See "IMPORTANT GROUNDING INSTRUCTIONS" found on page 4.
- 4) Install or locate this appliance only in accordance with the provided installation instructions.
- 5) Some products such as whole eggs and sealed containers – for example, closed glass jars – are able to explode and should not be heated in this oven.
- 6) Use this appliance only for its intended use as described in the manual. Do not use corrosive chemicals or vapors in this appliance. This type of oven is specifically designed to heat, cook, or dry food. It is not designed for industrial or laboratory use.
- 7) As with any appliance, close supervision is necessary when used by children.



- 8) Do not operate this appliance if it has a damaged cord or plug. If it is not working properly, or if it has been damaged or dropped.
- 9) This appliance should be serviced only by a qualified service personnel. Contact nearest authorized service facility for examination, repair or adjustment.
- 10) Do not cover or block any openings on this appliance.
- 11) Do not store this appliance outdoors. Do not use this product near water – for example, near a kitchen sink, in a wet basement, near a swimming pool, or similar locations.
- 12) Do not immerse cord or plug in water.
- 13) Keep cord away from heated surfaces.
- 14) Do not let cord hang over edge of table or counter.
- 15) When cleaning surfaces between the door and the oven that come together upon closing, use only mild, nonabrasive soaps or detergents applied with a sponge or soft cloth.
- 16) To reduce the risk of fire in the oven cavity:
 - a) Do not overcook food. Carefully attend appliance when paper, plastic, or other combustible materials are placed inside the oven to facilitate cooking.
 - b) Remove wire twist-ties from paper or plastic bags before placing bag in oven.
 - c) If materials inside the oven ignite, keep oven door closed, turn oven off and disconnect the power cord, or shut off power at the fuse or circuit breaker panel.
 - d) Do not use the cavity for storage purposes. Do not leave paper products, cooking utensils, or food in the cavity when not in use.
- 17) Liquids, such as water, coffee, or tea are able to be overheated beyond the boiling point without appearing to be boiling. Visible bubbling or boiling when the container is removed from the microwave oven is not always present. **THIS COULD RESULT IN VERY HOT LIQUIDS SUDDENLY BOILING OVER WHEN THE CONTAINER IS DISTURBED OR A UTENSIL IS INSERTED INTO THE LIQUID.**
- 18) This appliance is intended for household use only.

!! SAVE THESE INSTRUCTIONS !!



Important Grounding Instructions

This appliance must be grounded. In the event of an electrical short circuit, grounding reduces the risk of electric shock by providing an escape wire for the electric current. This appliance is equipped with a cord having a grounding wire with a grounding plug. The plug must be plugged into an outlet that is properly installed and grounded.

Three-pronged
(grounding) plug

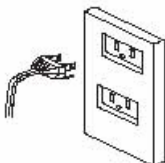

Properly polarized and
grounded outlet

WARNING-Improper use of grounding can result in a risk of electric shock.

Consult a qualified electrician or serviceman if the grounding instructions are not completely understood, or if doubt exists as to whether the appliance is properly grounded and either:

1. If it is necessary to use an extension cord, use only a 3-wire extension cord that has a 3-blade grounding plug, and a 3-slot receptacle that will accept the plug on the appliance. The marked electrical rating of the extension cord shall be equal to or greater than the rating of the appliance, or
2. Do not use an extension cord. If the power supply cord is too short, have a qualified electrician or serviceman install an outlet near the appliance.



PRECAUTIONS TO AVOID POSSIBLE EXPOSURE TO EXCESSIVE MICROWAVE ENERGY

- Do not attempt to operate this microwave oven with the door open because this can result in harmful exposure to microwave energy. It is important not to break or tamper with the safety interlocks.
- Do not place any object between the oven frame and the door or allow soil or cleaner residue to accumulate on sealing surfaces.
- Do not operate the oven if it is damaged. It is very important that the oven door closes properly and that there is no damage to the:
 - a) Door (including any dents)
 - b) Hinges and Latches (including broken or loose parts)
 - c) Door seals and Sealing surfaces
- The oven should not be adjusted or repaired by anyone except properly qualified service personnel.



Features and Benefits

- 0.6 cu.ft. Oven Cavity
- 10 Power Levels
- Eight instant one-touch setting buttons for common foods
- Six Express Cook one-touch settings
- Electronic Digital Display with Clock (LED)
- Turntable
- Time Cook
- Time and Weight Defrost
- Remind Signal
- Kitchen Timer

Specifications

Model.....	87025
Power Source.....	120V ~ 60Hz
Power Consumption.....	850 W
Maximum Output.....	600 W
Oven Capacity.....	0.6 cu.ft.
Turntable Diameter.....	9.6 inches
External Dimensions.....	17.8 x 10.3 x 13 inches
Net Weight.....	23.15 lbs



How to test for a microwave-safe dish:

To determine if a dish is microwave safe, place the dish in the microwave along with a glass measuring cup filled with one cup of water. Microwave for one minute on high and then carefully feel the dish. If it is warm, it is not microwave safe.

Arcing – The microwave term for sparks in the oven. Caused by:

- Metal or foil touching the side of the microwave
- Upturned edges of foil not wrapped around the food
- Metals in the microwave such as twisty ties, meat pins or metal rimmed dishes
- Recycled paper towels in the microwave that contain small flecks of metal

Materials for use in microwave

To avoid arcing and other hazards, follow these instructions for the use of safe materials in the microwave.

Browning dish	Follow manufacturer's instructions. The bottom of browning dish must be at least 3/16 inch (0.5 cm) above the turntable. Incorrect usage may cause the turntable to break.
Dinnerware	Microwave-safe only. Follow manufacturer's instructions. Do not use cracked or chipped dishes.
Glassware	Heat-resistant oven glassware only. Make sure there is no metallic trim. Do not use cracked or chipped dishes.
Oven cooking bags	Follow manufacturer's instructions. Do not close with metal tie. Make slits to allow steam to escape.
Paper plates/cups	Use for short-term cooking/warming only. Do not leave oven unattended while cooking.
Paper towels	Use to cover food for reheating and absorbing fat. Use with supervision for short-term cooking only.
Parchment paper	Use as a cover to prevent splattering or a wrap for steaming.
Plastic	Microwave-safe only. Follow the manufacturer's instructions. Boiling bags and tightly closed plastic bags should be slit, pierced or vented as directed by package. Due to various manufacturers you may receive varying performance results when using a bacon tray.
Plastic wrap	Microwave-safe only. Use to cover food during cooking to retain moisture. Do not allow plastic wrap to touch food.
Thermometers	Microwave-safe only.
Wax paper	Use as a cover to prevent splattering and retain moisture.

Materials to avoid in microwave

- Metal pans and bake ware
- Recycled paper products
- Non-heat-resistant glass
- Food storage bags
- Dishes with metallic trim
- Brown paper bags
- Non-microwave-safe-plastics (margarine tubs)
- Metal twist-ties

Setting up your microwave

Installation:

1) Remove all packing materials and accessories. Examine the oven for any damage such as dents or broken door. Do not install if oven is damaged.

2) Select a level surface that provides enough open space for ventilation. Allow for 3 inches of open space next to the sides and back of the microwave. Allow for 12 inches of open space above the microwave, and do not remove the legs from the bottom of the microwave.

3) Place the microwave as far away as possible from radios and televisions. Microwave may cause interference to these appliances.

4) Plug the microwave into a standard household outlet. Check the rating label of the microwave to ensure the voltage and frequency are compatible with the outlet.

5) Do not install microwave over a range cook top or other heat-producing appliance. Heat can damage the microwave and void the warranty.

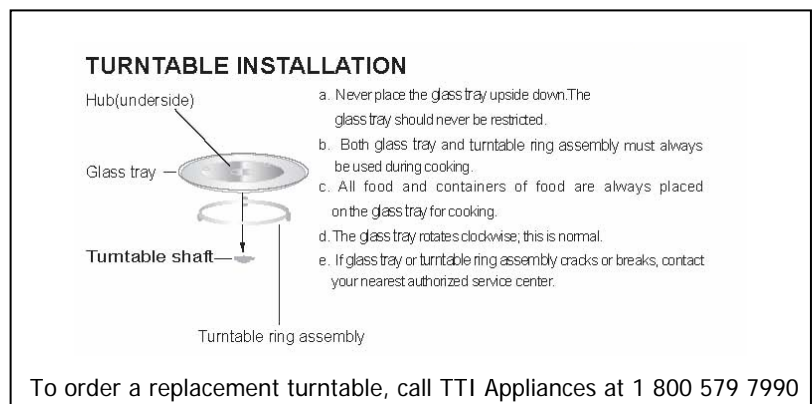
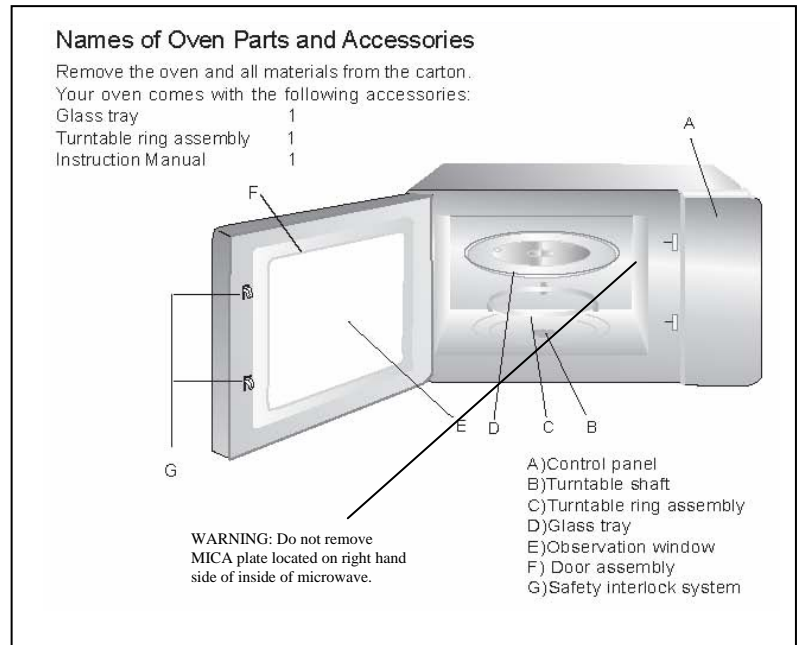

Control Panel Operation

Control Panel

Display Window

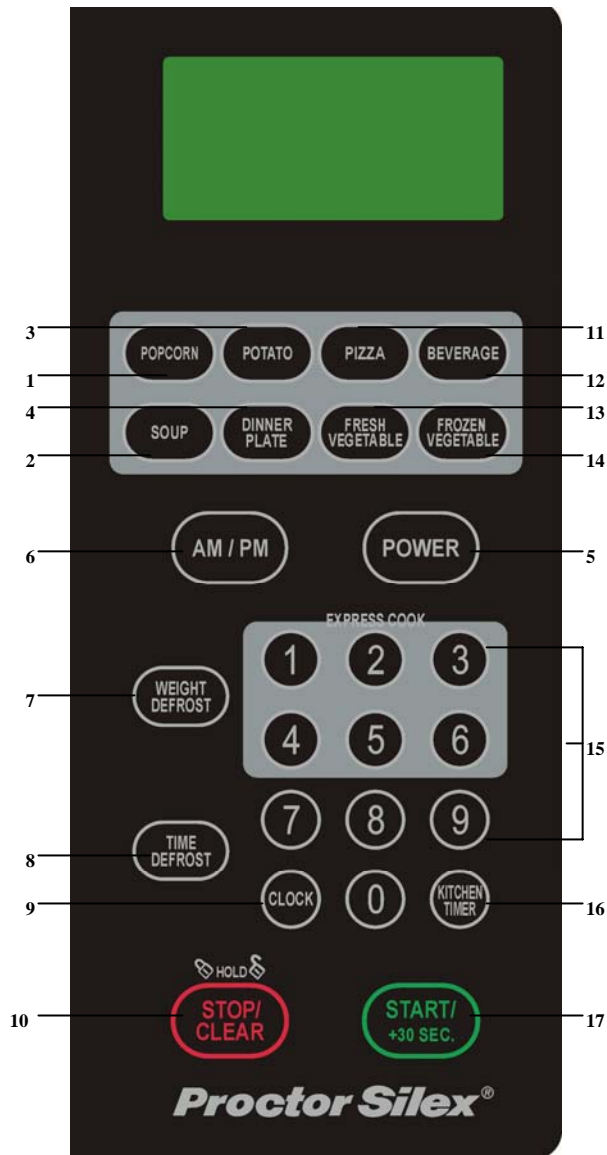

Display Window Icons*

- (1) Microwave
- (2) Defrost
- (3) High power
- (4) Low power
- (5) Time
- (6) Lock function for children
- (7) Auto cook
- (8) Ounce
- (9) Cup

		Page
1	POPCORN	12
2	SOUP	13
3	POTATO	12
4	DINNER PLATE	13
5	POWER	10
6	AM/PM	10/15
7	WEIGHT DEFROST	11
8	TIME DEFROST	12
9	CLOCK: setting time	10
10	STOP/CLEAR/CHILD LOCK: clears all previous settings if pressed before cooking starts. During cooking, press once to stop oven, twice to stop and clear all entries. See page 15 for child lock.	15
11	PIZZA	12
12	BEVERAGE	13
13	FRESH VEGETABLE	13
14	FROZEN VEGETABLE	14
15	NUMBER KEYS	10
16	KITCHEN TIMER	15
17	START/ +30 SEC.	10/11

* Note: Not all icons are used for all models

1. Power Level

Ten power levels are available. Press the "POWER" button repeatedly to scan through the different levels to make your selection.

Level	10	9	8	7	6	5	4	3	2	1
Power	100%	90%	80%	70%	60%	50%	40%	30%	20%	10%

High level indicator lights up and will flash while in operation

Low level indicator lights up and will flash while in operation

2. Clock Setting

When the microwave oven is plugged into an outlet, the oven will display "0:00"

- 1) Press "CLOCK"
- 2) Enter the correct time by pressing the numbers keys
- 3) Choose AM or PM by pressing AM/PM button
- 4) Press "CLOCK" to finish

3. One-stage cooking

To cook food at only one power level:

- 1) Press "POWER" repeatedly to select a power level.
- 2) Enter a cooking time. The maximum cooking time is 99 minutes and 99 seconds.
- 3) Press "START."

4. Two-stage cooking

To cook food at one power level, and then at a second power level immediately after:

- 1) Press "POWER" repeatedly to select a power level for stage 1.
- 2) Enter a cooking time for stage 1. The maximum cooking time is 99 minutes and 99 seconds.
- 3) Then press "POWER" repeatedly to select a power level for stage 2.
- 4) Enter a cooking time for stage 2.
- 5) Press "START" to begin.
- 6) You will hear a beep sound when stage 1 finishes and stage 2 begins.

5. Express Cook

Buttons 1-6 on the keypad are for express cooking. To cook food at 100% power with the touch of a button, press "1" for one minute, "2" for 2 minutes, and so on up until "6" for 6 minutes.

6. +30 SEC

The "+30 SEC" button can be used to set the time for cooking or for adding on time while food is already cooking. To set the time for cooking, press "+30 SEC" button repeatedly to increase the time to your desired cooking time. Press "+30 SEC" button during cooking to increase the cooking time by 30 seconds. The maximum amount of time that can be added is 99 minutes and 59 seconds.

7. Defrost by Weight Function

- 1) Press "WEIGHT DEFROST"
- 2) Enter the weight in ounces (4-100 oz).
- 3) Press "START."

8. Time Defrost Function

- 1) Press "TIME DEFROST."
- 2) Enter defrosting time.
- 3) The default power level for defrost is 3. To change the power level, press "POWER" once. Then enter the desired power level (1-10) by pressing the number keys on the keypad.
- 4) Press "START."

9. Popcorn

-Do not use this button if the size of the popcorn bag is less than 1.75 oz. (50 grams).

- 1) Press "Popcorn" once for a popcorn bag size of 1.75 oz. Then press "START."
("1.75 oz." will appear in display)
- 2) Press "Popcorn" twice for a popcorn bag size of 3.0 oz. Then press "START."
("3.00 oz." will appear in display)
- 3) Press "Popcorn" three times for a popcorn bag size of 3.5 oz. Then press "START."
("3.50 oz." will appear in display)

Always follow manufacturer's instructions for popcorn if the cooking time for the pre-set buttons differs from the manufacturer's recommended time. Never leave popcorn cooking unattended.

10. Potato

- 1) Press "Potato" once for a 8 oz. (227 grams) potato. Then press "START."
("1" will appear in display)
- 2) Press "Potato" twice for a 16 oz. (454 grams) potato. Then press "START."
("2" will appear in display)
- 3) Press "Potato" three times for a 24 oz. (680 grams) potato. Then press "START."
("3" will appear in display)

11. Pizza

- 1) Press "Pizza" once for one slice (approximately 3 oz./85 grams). Then press "START."
("1" will appear in display)
- 2) Press "Pizza" twice for two slices (approximately 6 oz./170 grams). Then press "START."
("2" will appear in display)
- 3) Press "Pizza" three times for three slices (approximately 9 oz./255 grams). Then press "START."
("3" will appear in display)

12. Beverage

- 1) Press "Beverage" once for one cup (250 ml). Then press "START."
("1" will appear in display)
- 2) Press "Beverage" twice for two cups (500 ml). Then press "START."
("2" will appear in display)
- 3) Press "Beverage" three times for three cups (750 ml). Then press "START."
("3" will appear in display)

13. Soup

- 1) Press "Soup" once for 4 oz. (113 grams). Then press "START."
("4.00 oz." will appear in display)
- 2) Press "Soup" twice for 8 oz. (227 grams). Then press "START."
("8.00 oz." will appear in display)
- 3) Press "Soup" three times for 12 oz. (340 grams). Then press "START."
("12.00 oz." will appear in display)
- 4) Press "Soup" four times for 16 oz. (454 grams). Then press "START."
("16.00 oz." will appear in display)

14. Dinner Plate

- 1) Press "Dinner Plate" once for 9 oz. (255 grams). Then press "START."
("9.00 oz." will appear in display)
- 2) Press "Dinner Plate" twice for 12 oz. (340 grams). Then press "START."
("12.00 oz." will appear in display)
- 3) Press "Dinner Plate" three times for 18 oz. (510 grams). Then press "START."
("18.00 oz." will appear in display)

15. Fresh Vegetable

- 1) Press "Fresh Vegetable" once for 4 oz. (113 grams). Then press "START."
("4.00 oz." will appear in display)
- 2) Press "Fresh Vegetable" twice for 8 oz. (227 grams). Then press "START."
("8.00 oz." will appear in display)
- 3) Press "Fresh Vegetable" three times for 16 oz. (454 grams). Then press "START."
("16.00 oz." will appear in display)

16. Frozen Vegetable

- 1) Press "Frozen Vegetable" once for 4 oz. (113 grams). Then press "START."
("4.00 oz." will appear in display)
- 2) Press "Frozen Vegetable" twice for 8 oz. (227 grams). Then press "START."
("8.00 oz." will appear in display)
- 3) Press "Frozen Vegetable" three times for 16 oz. (454 grams). Then press "START."
("16.00 oz." will appear in display)

17. AM/PM and Clock Functions

To determine whether the time on the display is in AM or PM, press the "AM/PM" button. The answer will be displayed for three seconds.

To determine the time in the middle of cooking, press "Clock". The time will display for six seconds.

In the timer mode, press "Clock" to determine the time at which the microwave will automatically begin cooking.

To determine the power level while cooking, press the "Power" button and the current power level will be displayed.

18. Child Lock

- 1) Press "Stop/Clear" button and hold for 3 seconds. A long beep will sound. The microwave is now locked and cannot be used.
- 2) To unlock, press and hold "Stop/Clear" button for 3 seconds until a long beep sounds. The microwave is now unlocked.

19. Stop/Clear

- 1) To stop the microwave at any point during cooking, press "Stop/Clear".
- 2) To clear the display window, press "Stop/Clear".

20. Kitchen Timer

- 1) Press "Kitchen Timer" button, LED display will show "00:00".
- 2) Input length of time for countdown, maximum 99 minutes 99 seconds.
- 3) Press "START" to begin, LED counts down. Icon "clock" on.
- 4) When countdown ends, it will beep five times.

Care and Cleaning

-Keep the inside of the oven clean. Food particles and liquid stains that stick to the oven walls can hinder the operation of the microwave.

-Clean up spilled liquids immediately with a damp towel and mild soap. Avoid abrasive cleaners.

-To loosen food particles and stains, heat up two cups of water with lemon juice at high power for four minutes, or until boiling. Let stand in the microwave for three minutes before cleaning.

-Remove the glass turntable from the microwave while cleaning. Do not put the turntable directly in water immediately after cooking, or it may break. Wash the turntable in warm, soapy water or in the dishwasher.

-The outside of the microwave can be cleaned with damp towel and mild soap. Do not let water seep into any openings or damage may occur to the microwave.



Troubleshooting



Problem	Possible Causes	What to do
1. Dim Oven Light	1. In low power cooking, oven light may become dim	1. This is normal
2. Steam accumulating on door or hot air coming out of vents during cooking	2. Food releases steam during cooking	2. This is normal
3. Oven is started accidentally with no food in it	3. Microwave is started accidentally with no food in it	3. No damage will occur if the microwave runs for less than 20 seconds
4. Interference with TV reception	4. Microwave operation may affect radio and TV reception	4. This is normal
5. Microwave will not start	5a. Power cord not plugged in tightly 5b. A fuse is blown or circuit breaker trips 5c. Problem with electrical outlet	5a. Unplug, wait 10 seconds, then plug in again 5b. Replace fuse or reset circuit breaker 5c. Consult with professional electrician
6. Glass turntable makes noise during operation	6. The microwave cavity is dirty	6. Clean the microwave and Turntable rest with warm water and microwave-safe cleaning products
7. Popcorn is over-cooked or under-cooked with "Popcorn" Easy Button	7. Incorrect power level selected for size of popcorn bag	7. Refer to page 12 for "Popcorn" Button instructions. Always follow manufacturer's instructions for popcorn if the cooking time for the pre-set buttons differs from the manufacturer's recommended time. Never leave popcorn cooking unattended.
8. One of the display icons begins flashing when the microwave isn't cooking	8. A cooking function was accidentally activated	8. Press "Stop/Clear" button



LIMITED 1-YEAR WARRANTY

What does this warranty cover?

- Any defect in materials or workmanship in the manufactured product

What does this warranty not cover?

- Service trips to your home to teach you how to use the product.
- Improper installation.
- Failure of the product if it is abused, misused, altered or used in any manner not in accordance with manufacturer's instructions.
- Products that are used for a commercial purpose.
- Replacement of house fuses or resetting of circuit breakers.
- Damage to the product caused by accident, fire, floods or acts of God.
- Any service to the product
- The glass turntable.
- **Incidental or consequential damage caused by possible defects with this appliance, its installation or repair.**

For how long after the original purchase?

- One (1) year.

How do I make a return?

Return to the retailer from which it was purchased, along with a copy of the store receipt within the given period of time allowed for returns by the retailer (i.e. 90 days). After this period of time, contact TTI Appliances at 1 800 579 7990.

How does state or province law relate to this warranty?

-This warranty is extended to the original purchaser only for products purchased for household use within the country of purchase. **Some states and provinces do not allow the exclusion or limitation of incidental or consequential damages. This warranty gives you specific legal rights, and you may also have other rights which vary from state to state or province to province.**

-Exclusion of implied warranties: Except where prohibited or restricted by law, there are no warranties, whether express, oral or statutory which extend beyond the description on the face hereof, including specifically the implied warranties of merchantability or fitness for a particular purpose.

Warrantor: TTI Appliances, Los Angeles, CA 90025

Consumer Support:

Phone: 1-800-488-5080 (Monday – Friday 8:00 AM – 5:00 PM ET)

Email: support@ps-microwaves.com

On the web: www.ps-microwaves.com

To order replacement turntables:

Phone: 1-800-579-7990

Email: support@ps-microwaves.com

Please complete and return warranty registration card.