

## READ BEFORE USE

### 使用前阅读

Visit [www.hamiltonbeach.cn](http://www.hamiltonbeach.cn) for our complete line of products and Use and Care Guides – as well as delicious recipes, tips, and to register your product online!

有关我们所有系列产品的，使用与维护指南 – 以及美味食谱、生活小贴士和产品在线注册的更多信息，请访问 [www.hamiltonbeach.cn](http://www.hamiltonbeach.cn)。

### Questions?

Please call us – our friendly associates are ready to help.  
China: 400-852-2655

### 如有疑问？

请致电我们，我们的团队随时准备为您提供帮助。  
中国大陆免费客服热线：  
400-852-2655

官方网站：[www.hamiltonbeach.cn](http://www.hamiltonbeach.cn)

型号：49981-CN

此说明书中图片仅供参考，  
产品以实物为准。

使用本设备前，我们建议您仔细阅读这些说明。



# Hamilton Beach®

## The Scoop™ Single-Serve Coffeemaker

## The Scoop™ 精英式咖啡机

English ..... 2

简体中文 ..... 11

# IMPORTANT SAFEGUARDS

When using electrical appliances, basic safety precautions should always be followed to reduce the risk of fire, electric shock, and/or injury to persons, including the following:

1. Read all instructions.
2. Do not touch hot surfaces. Use handles or knobs. Care must be taken, as burns can occur from touching hot parts or from spilled, hot liquid.
3. To protect against electric shock, do not place cord, plug, or coffeemaker in water or other liquid.
4. Close supervision is necessary when any appliance is used by or near children.
5. Unplug from outlet when the coffeemaker is not in use and before cleaning. Allow to cool before putting on or taking off parts and before cleaning the appliance.
6. Coffeemaker must be operated on a flat surface away from the edge of counter to prevent accidental tipping.
7. Do not operate any appliance with a damaged cord or plug, or after the appliance malfunctions or has been damaged in any manner. Call our toll-free customer service number for information on examination, repair, or adjustment.
8. The use of accessory attachments not recommended by the appliance manufacturer may cause injuries.
9. Do not use outdoors.
10. Do not let cord hang over edge of table or counter or touch hot surfaces, including stove.
11. Do not place on or near a hot gas or electric burner, or in a heated oven.
12. Do not use appliance for other than intended use.
13. **WARNING:** To reduce the risk of fire or electric shock, do not remove the bottom cover of the coffeemaker. There are no user-serviceable parts inside. Repair should be done by authorized service personnel only.
14. To disconnect, turn any control to the OFF (O) position and then remove plug from wall outlet.

## SAVE THESE INSTRUCTIONS!

### OTHER CONSUMER SAFETY INFORMATION

**This appliance is intended for household use only.**

The length of the cord used on this appliance was selected to reduce the hazards of becoming tangled in or tripping over a longer cord. If a longer cord is necessary, an approved extension cord may be used. The electrical rating of the extension cord must be equal to or greater than the rating of the appliance. Care must be taken to arrange the

extension cord so that it will not drape over the countertop or tabletop where it can be pulled on by children or accidentally tripped over.

To avoid an electrical circuit overload, do not use another high-wattage appliance on the same circuit with this appliance.

# Parts and Features

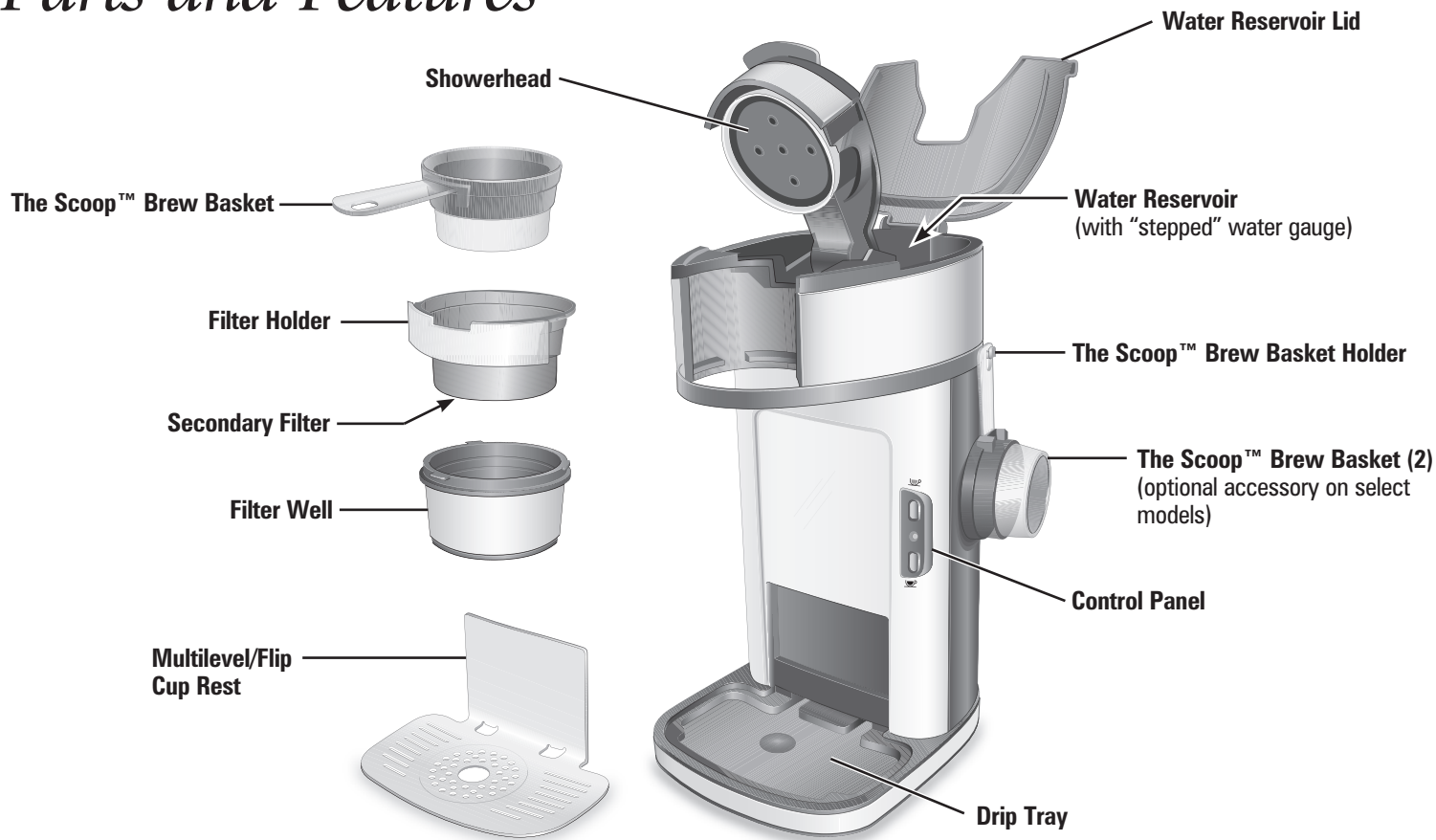

# Before First Use

**⚠ WARNING Burn Hazard.**

To avoid contact with hot water:  
• Do not use more than 14 ounces (410 ml) of water.

- Fill reservoir with mug or cup into which the water will be brewed.
- Fully insert mug or cup under filter basket.

Run one or two clean water cycles through the machine before first use.

**AUTOMATIC SHUTOFF:** The coffeemaker will automatically shut off after brew cycle is complete.

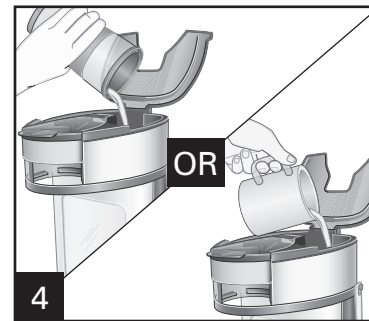
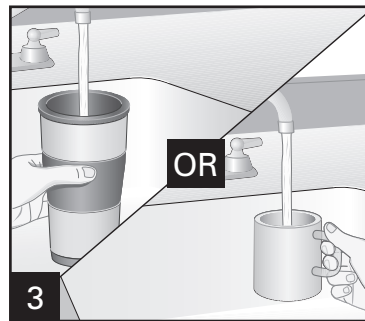
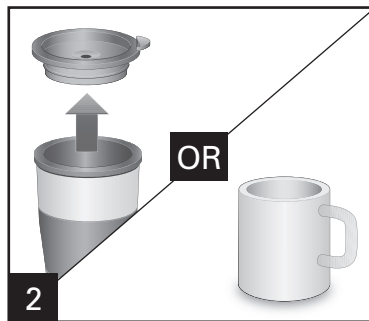
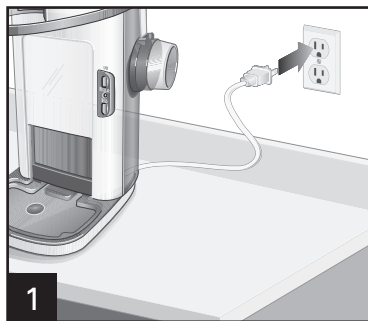

Water reservoir has two water levels: one for 8 oz. (250 ml) (minimum) and one for 14 oz. (410 ml) (MAX line) of water.



## *Before First Use* (cont.)



Ensure the multilevel/flip cup rest is firmly secured and snapped into place.



Discard liquid when clean water cycle is finished. Coffeemaker is now ready for use. Follow instructions on page 6.

# How to Use

SEE ALSO "USING THE  AND  SETTINGS" SECTION ON PAGE 8.

**AUTOMATIC SHUTOFF:** The coffeemaker will automatically shut off after brew cycle is complete.

**FOR HOTTER COFFEE:** Rinse mug or travel mug with warm water before brewing.

**⚠ WARNING Burn Hazard.**

To avoid contact with hot coffee or water:

- Do not use more than 14 ounces (410 ml) of water.

- Fill reservoir with mug or cup into which the coffee will be brewed.
- Fully insert mug or cup under filter basket.

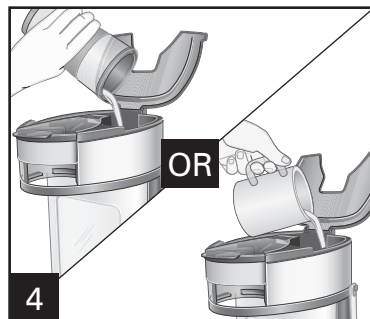
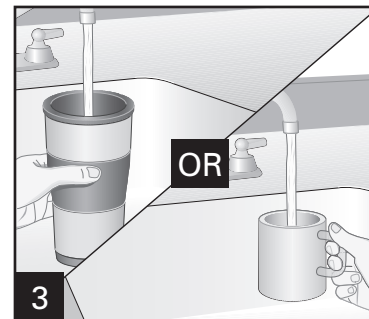
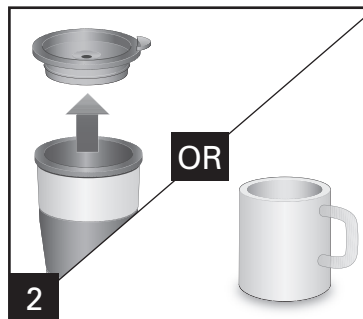
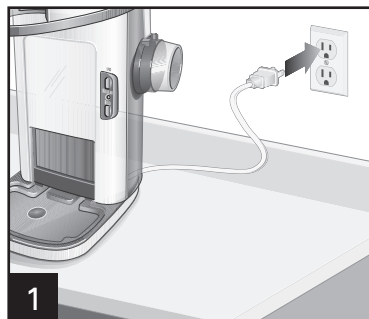

Water reservoir has two water levels: one for 8 oz. (250 ml) (minimum) and one for 14 oz. (410 ml) (MAX line) of water.



Ensure the multilevel/flip cup rest is firmly secured and snapped into place.

# How to Use (cont.)



**WARNING!** Burn Hazard. To avoid overflow, keep ground coffee below MAX fill line.

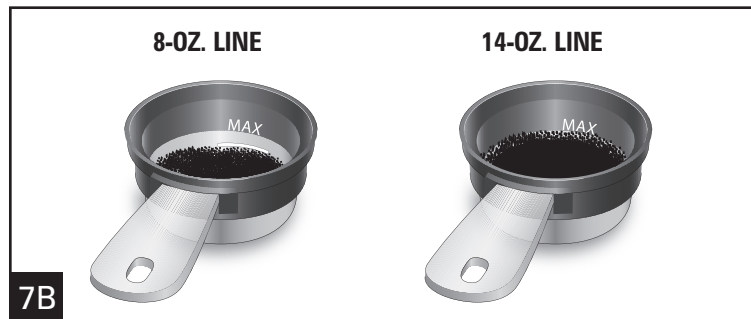

Scoop coffee grounds directly into the Scoop™ filter provided, using the measurement instructions shown above. Or, if you prefer to use a traditional coffee scoop method, measure coffee in the following way:  
8-oz. cup = 2 tablespoons ground coffee  
14-oz. cup = 3 tablespoons ground coffee  
To get the perfect taste you prefer, adjust measurements up or down accordingly.

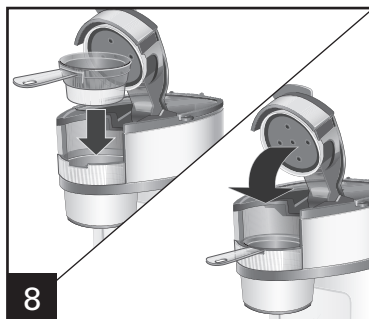





Use the ☕ setting for flavored, decaf, finely ground, and premium brand ground coffees such as Starbucks® and Dunkin' Donuts®.

Press ☕ or ☕ to begin flow of coffee. Coffeemaker will automatically shut off when brewing is complete. To stop brewing midcycle, press either button and the unit will turn off.

**NOTE:** If there is no water in the water reservoir, and a brew button is pushed, the unit will not brew. The LED light will blink for 5 seconds, then turn coffeemaker OFF (O).

Starbucks® is a registered trademark of Starbucks U.S. Brands, LLC.  
Dunkin' Donuts® is a registered trademark of DD IP Holder LLC.

## Using the and Settings

- This unit uses ground coffee ONLY. It is **NOT** intended for use with coffee “pods.”
- Use the  setting when a stronger cup of coffee is desired. Use the  setting for flavored, decaf, finely ground, and premium brand ground coffees such as Starbucks® and Dunkin’ Donuts®.  
Starbucks® is a registered trademark of Starbucks U.S. Brands, LLC.  
Dunkin’ Donuts® is a registered trademark of DD IP Holder LLC.
- When using whole bean coffee, a standard automatic drip coffee grind will yield best results. Be careful not to overgrind, since very finely ground coffee can cause overflow in this unit.
- If overflow occurs, first try switching the unit to the  setting, OR use slightly less grounds. The  setting dispenses water at a slower rate, allowing more contact time and better coffee extraction from the coffee.

## Tips for Best-Tasting Coffee

- All coffees are made from either arabica beans or robusta beans, or some combination of both. Arabica beans are slightly more expensive, but tend to produce better-tasting coffee.
- Ground coffee will become stale much faster than whole beans. If buying preground coffee, choose a package with the latest expiration date or a smaller quantity.
- Try to use freshly ground coffee within about a week of grinding.
- Using a water filter, filtered water, or bottled water will yield better-tasting coffee than tap water.
- Make sure your coffeemaker is clean. See “Care and Cleaning” section.

# Care and Cleaning



## WARNING Shock Hazard.

Do not immerse cord, plug, or coffeemaker in any liquid.

All coffeemakers should be cleaned at least once a month (once a week for areas with hard water).

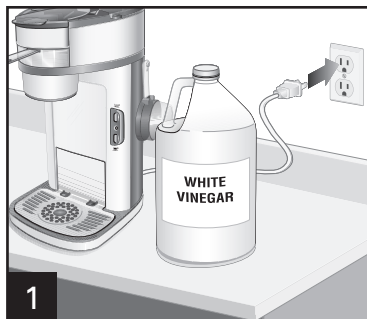

1



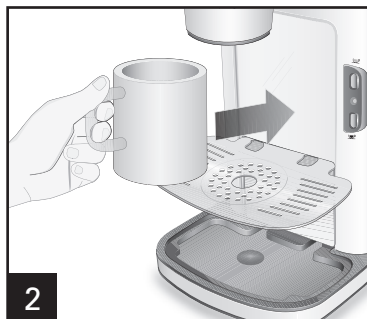

Pour 1/2 cup (125 ml) of plain white vinegar and 1/2 cup (125 ml) of cold water into reservoir.

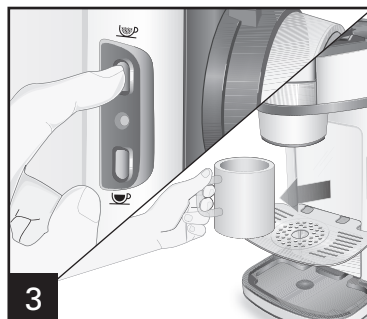

2



3

Press the  or  button once. After 30 seconds, turn unit OFF () using the  or  button and allow vinegar to clean. After 30 minutes, plug in unit and allow it to finish the brew cycle. When brew cycle is finished, wait for unit to cool. Empty cup and rinse.



4

Replace accessories. Run two to three cycles of cold tap water. The unit is now cleaned and ready to make coffee.



5

## TO CLEAN THE SCOOP™

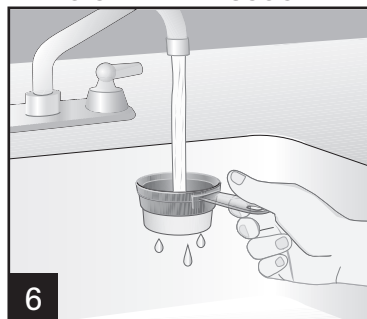

6

Discard grounds after each use. Rinse and/or clean with soapy water. Towel dry or hang dry on brew basket holder.



**DISHWASHER-SAFE**

**NOTE:** The Scoop™ brew basket should be cleaned daily, and the filter holder should be cleaned at least once a week.

# Troubleshooting

## PROBLEM

## PROBABLE CAUSE

Coffee tastes bad.

- Coffeemaker needs cleaning.
- Coffee ground too coarsely or too finely. Set coffee grinder to automatic drip grind.
- Poor coffee quality and freshness.
- Poor water quality (use filtered or bottled water).

Water on counter under unit.

- Overfilled water reservoir. Also check cup used to fill reservoir. Some mugs/cups do not pour cleanly and can dribble water down the side of the cup and onto counter.

Coffeemaker will not brew and LED light is blinking.

- Add water. If there is no water in the water reservoir and a brew button is pushed, the unit will not brew.

Weak coffee.

- First, try brewing using the ☕ setting. If coffee is still too weak, adjust water/coffee ratio by using slightly less water and/or more grounds. Be careful to not exceed the MAX line for grounds.

Coffee overflows from brew basket.

- Use a lesser amount of ground coffee.
- Use the ☕ setting for flavored, finely ground, premium brand ground coffees, and decaf coffees.
- When using whole bean coffee, a standard automatic drip coffee grind will yield best results. Be careful not to overgrind, since very finely ground coffee can cause overflow in this unit.

Coffee overflows from mug or travel mug.

- To prevent coffee overflowing from a mug/travel mug, ensure the SAME cup into which coffee will be brewed is also used to fill the water reservoir.

# 重要安全说明

为避免发生火灾，触电以及人身伤害，在使用家用电器时，需遵守以下基本安全防护措施：

1. 阅读所有相关说明。
2. 请勿直接接触任何发热表面。请使用手柄或者旋钮。特别注意：在直接接触电器高温部件或溅到高温液体的情况下，可能造成皮肤烫伤。
3. 为防止触电，请勿将电源线、插头或咖啡机放入水或其他液体中。
4. 当电器由儿童使用或距离儿童较近时，需有成人看护。
5. 咖啡机在清洗前或在未使用时，需拔掉电源插头。拆装咖啡机部件以及清洁前，必须让咖啡机冷却。
6. 咖啡机必须放在平整桌面进行操作，远离桌子边缘，以防其意外倾翻。
7. 当电源线或电插头受损，电器出现故障或因任何其他方式出现电器损坏时，请勿使用任何电器。请拨打我们的免费售后服务电话，咨询有关电器检查、修理或调整的相关信息。
8. 使用非电器制造商推荐的配套附件可能会带来伤害。
9. 请勿在户外使用。
10. 请勿将电源线搭置在桌台边缘上以及与发热表面接触，包括加热器。
11. 请勿靠近或放置在燃气或电炉上，或放进加热烤箱内。
12. 请勿将电器用作其他非预期用途。
13. **警告：**为防发生火灾或触电，请勿取下此咖啡机的底盖。此咖啡机内部无任何用户可维修的部件。仅允许授权的维修人员执行维修。
14. 断开咖啡机电源时，先将控制按钮调至 OFF (O) 位置，再拔除插头。

## 请妥善保管这些说明！

### 其他用户安全信息

**此电器建议于家庭使用。**

此电器的电源线长度是经特别设计，以防电源线缠绕或绊倒他人。倘若需要更长的电源线，可使用批准的电源延长线。电源延长线的额定电功率必须等于或大于此电器的额定电功率。电源延长线使用时需特别注意，以防将其搭设在桌面上，造成儿童扯拉或绊倒他人。

为防电路过载，请勿在此电器的同一电路上使用其他高功率电器。

# 部件与功能

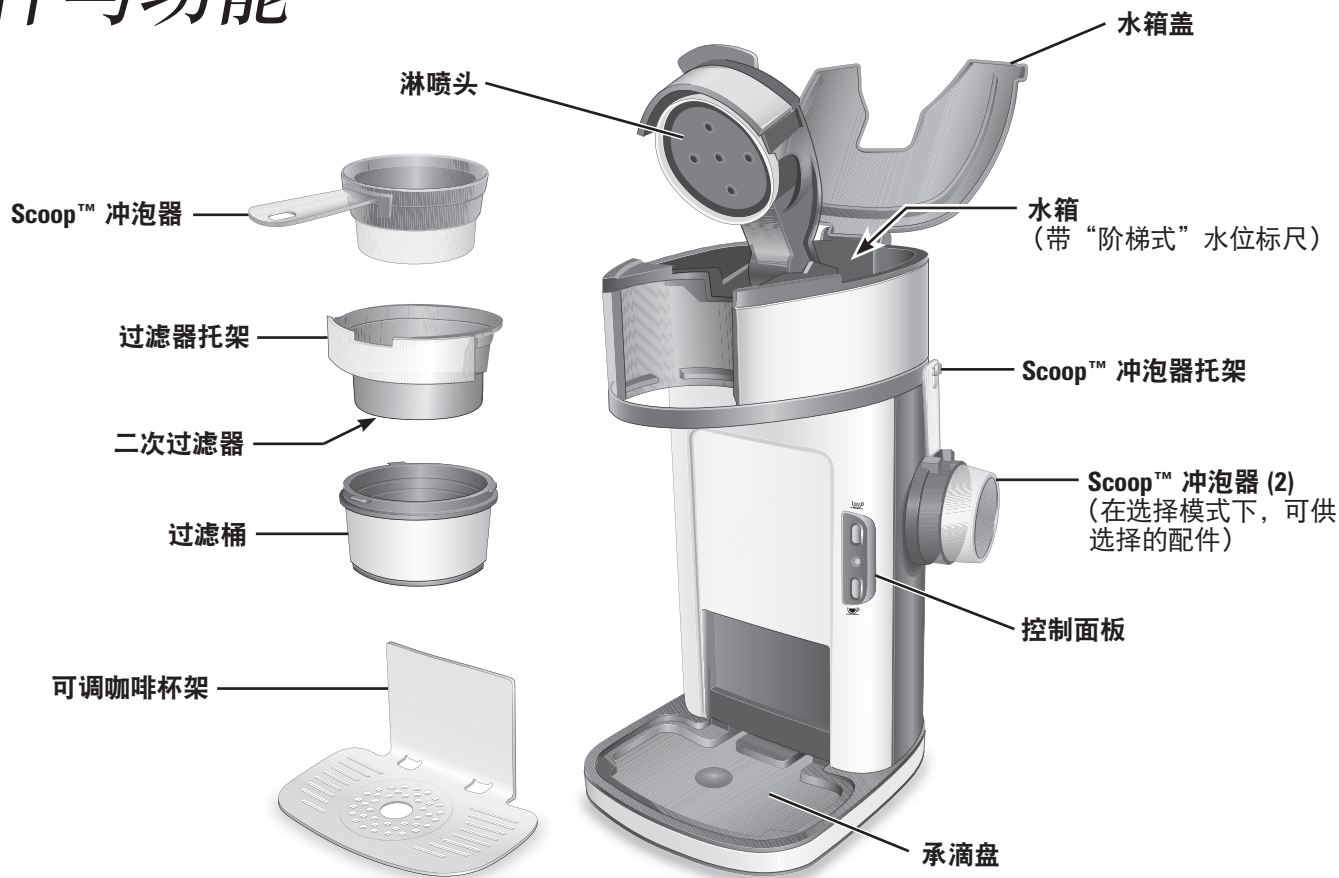



# 首次使用前

在第一次使用机器前，用洁净的水运行机器一到两个循环。

**自动关闭：**在一次冲泡完成后，咖啡机将自动关闭。

**⚠ 警告 烫伤危险。**

为避免触到热水：

- 请勿使用超过 14 盎司（410 毫升）的水。

- 使用马克杯或咖啡杯向水箱中加入用来冲泡咖啡的水。
- 将马克杯或咖啡杯放在过滤桶下面。

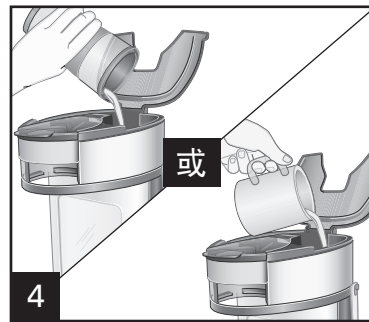
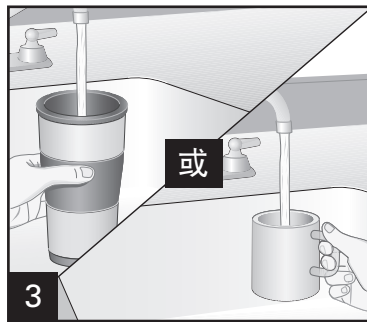
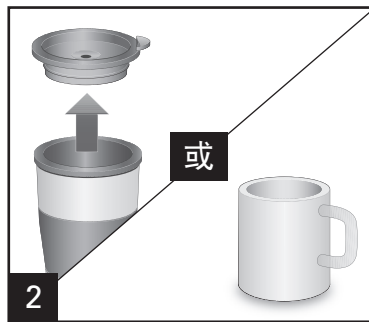
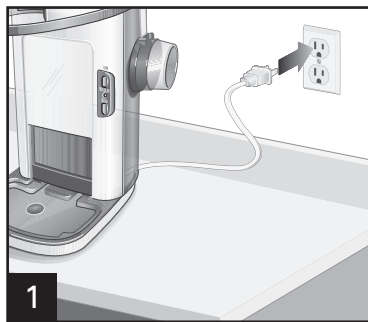

水箱有两个标准水位：  
8 盎司（250 毫升）（最小水位）  
和 14 盎司（410 毫升）（最大水位）。

# 首次使用前 (续)

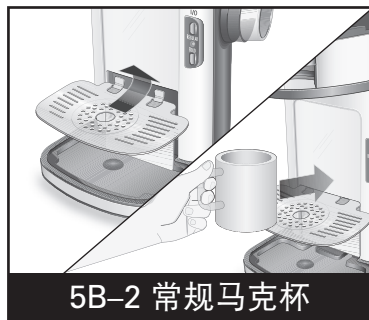
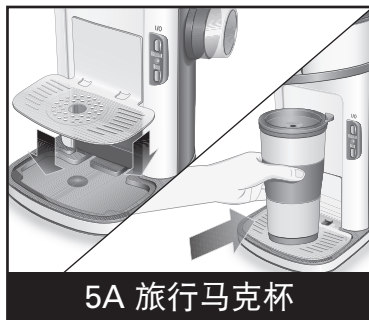

确保可调咖啡杯架已经固定，并且已经扣在合适位置。

当完成一个清水循环后，去除液体。现在咖啡机可以准备使用了。遵照第 15 页的说明。

# 如何使用

另见第 17 页“使用 ☕ (常规) 和 ☕ (加浓) 设置”章节。

**自动停止：**冲泡周期完成后，咖啡机将自动关闭。

**冲泡更热的咖啡：**在冲泡前，用温水冲洗马克杯或旅行马克杯。

**警告 烫伤危险。**

为了避免触到热咖啡或水：

• 请勿使用超过 14 盎司 (410 毫升) 的水。

- 使用马克杯或咖啡杯向水箱中加入用来冲泡咖啡的水。
- 完全将马克杯或咖啡杯放在过滤桶下面。

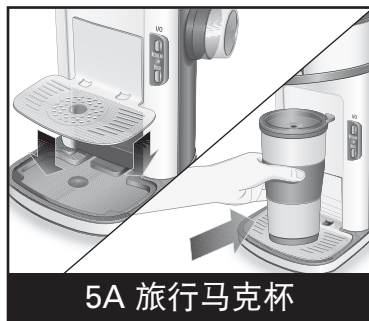
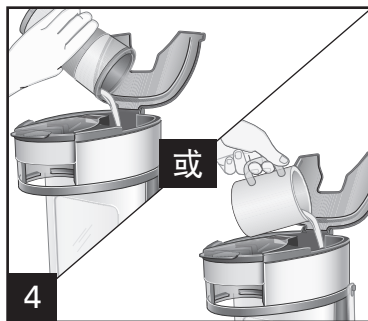
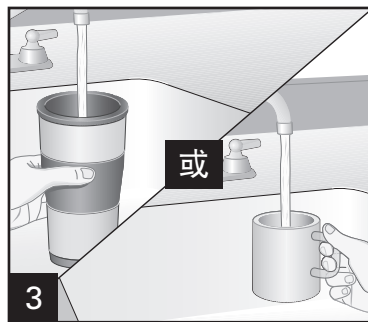
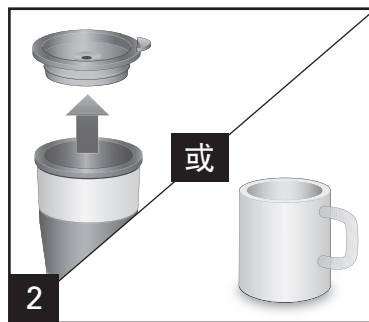
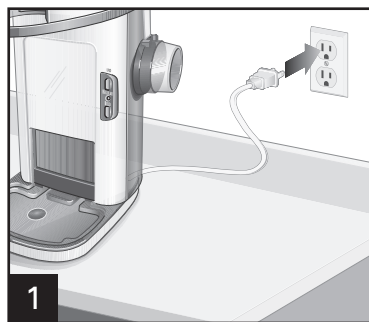

水箱有两个标准水位：

8 盎司 (250 毫升) (最小水位) 和

14 盎司 (410 毫升) (最大水位)。

确保可调咖啡杯架已经固定，并且已经扣在合适位置。

# 如何使用 (续)

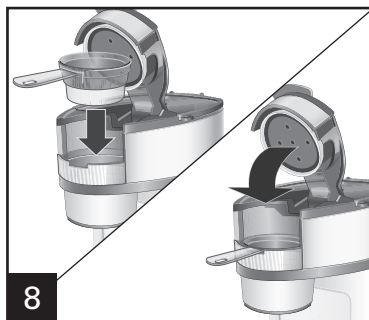
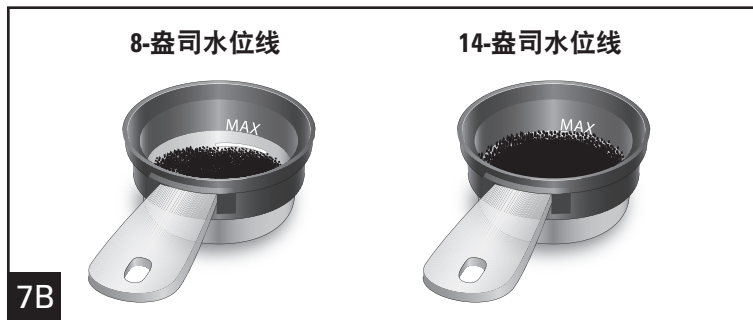
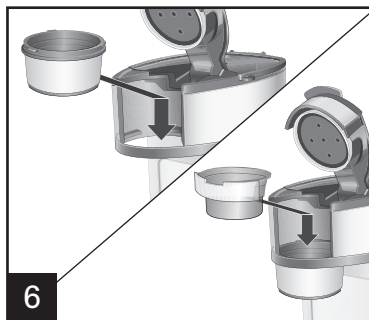

**7A** 警告！烫伤危险。为避免溢出，请勿让咖啡粉超过最大加注线。

**7B** 根据上方所示量度说明，用勺子将咖啡粉直接加注到 Scoop™ 过滤器中。或者，如果你更喜欢使用传统的咖啡勺取方法，用以下方法量测咖啡量：

8 盎司杯 = 30毫升咖啡粉

14 盎司杯 = 45毫升咖啡粉

为达到你最喜欢的口味，相应地上下调整咖啡量的量取。

使用 ☕ (加浓) 设置冲泡美味、脱因、精制高级品牌的咖啡粉，例如 Starbucks® 以及 Dunkin' Donuts®。



按下 ☕ (常规) 或 ☕ (加浓) 开始冲泡咖啡。当冲泡完成后，咖啡机将自动关闭。若中途停止冲泡，按下任一按钮，咖啡机将停止。

**注意：**若水箱中没有水，即使按下冲泡按钮，机器也不会冲泡。LED 灯将闪烁 5 秒钟，随后咖啡机关闭 (O)。

Starbucks® 是 Starbucks U.S. Brands, LLC 的注册商标。



Dunkin' Donuts® 是 DD IP Holder LLC 的注册商标。

## 使用 (常规) 和 (加浓) 设置

- 此装置仅适用咖啡粉。不用于咖啡豆。
- 当需要冲泡较浓口味的咖啡时，使用  (加浓) 设置。  
使用  (加浓) 设置冲泡美味、脱因、精制高级品牌的咖啡粉，例如 Starbucks® 以及 Dunkin' Donuts®。

Starbucks® 是 Starbucks U.S. Brands, LLC 的注册商标。

Dunkin' Donuts® 是 DD IP Holder LLC 的注册商标。

- 当使用全豆咖啡时，采用标准自动滴流咖啡研磨将取得最好的效果。由于非常细的咖啡粉会从咖啡勺的滤网中渗出，注意请勿过度研磨。
- 若发生溢出，首先尝试将咖啡机调至  (加浓) 设置状态。或放入更少的咖啡粉。 (加浓) 设置慢速分配水，使接触时间更长，从而更好地从咖啡中提取咖啡精华。

## 冲泡美味咖啡的技巧

- 所有咖啡都是采用阿拉比卡咖啡豆或罗布斯塔咖啡豆制造，或是两者的混合物。阿拉比卡咖啡豆的价格略贵，但能冲泡出更美味的咖啡。
- 研磨咖啡粉比整豆更容易失去香味。如果购买已经磨好的咖啡，选择保质期最长或数量较小的包装袋。
- 最好使用在一个星期内研磨的新鲜咖啡粉。
- 使用水过滤器，过滤的水或瓶装水比自来水冲泡的咖啡口感更好。
- 确保你的咖啡机保持干净。见“保养和清洁”章节。

# 保养和清洁



警告

烫伤危险。

请勿将电源线、电插头或咖啡机浸入任何液体中。

应至少每月一次对咖啡机进行整体清洗（使用硬质水的地区需每星期一次）。

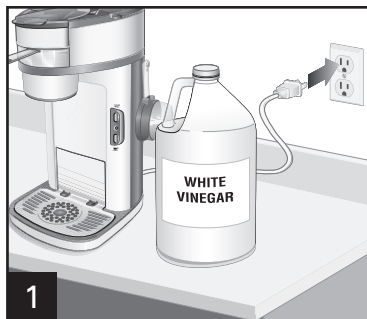

1

倒入 1/2 杯（125 毫升）纯白醋和 1/2 杯（125 毫升）冷水进水箱。

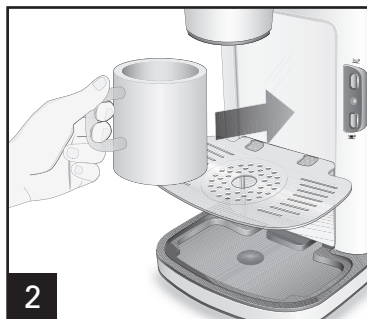

2

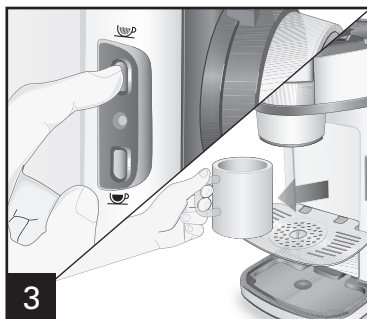

3

按 ☕（常规）或 ☕（加浓）按钮一次。在 30 秒后，使用 ☕（常规）或 ☕（加浓）按钮关闭 (O) 咖啡机，并且让醋发挥清洗效果。在 30 分钟后，接通咖啡机电源，让其完成一次冲泡循环。当冲泡循环完成后，等待咖啡机冷却。倒空杯子内的液体并清洗。



4

更换配件。用冷自来水运行两至三个循环。此时咖啡机已处于清洁状态，准备冲泡咖啡。



5

## 清洁 Scoop™ 冲泡器

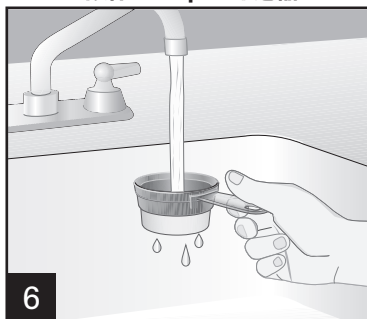

6

在每次使用后，倒掉咖啡渣。用洗洁精冲洗和/或清洁。冲泡器托架用毛巾擦干或悬挂晾干。



## 洗碗机安全

注意：应每日清洗 Scoop™ 冲泡器，并且每周至少冲洗一次过滤器托架。

# 故障排除

## 故障

## 可能原因

咖啡口味差。

- 咖啡机需要清洁。
- 咖啡粉太粗或太细。将咖啡研磨机设置为自动研磨状态。
- 咖啡品质或新鲜度差。
- 水质差（采用过滤或瓶装水）

水漏出。

- 水箱内装水过多。也需要检查装水进水箱的水杯。马克杯/咖啡杯中的水未倾倒干净，倒放时，会导致水沿着杯壁流出。

咖啡机没有冲泡，并且 LED 灯一直在闪烁。

- 加水。如果水箱里没有水，即使按下冲泡按钮，此咖啡机也不会冲泡。

咖啡口味很淡。

- 首先，尝试使用 ☕（加浓）模式设置。如果咖啡口味仍然很淡，在冲泡咖啡时少加水和/或多加咖啡粉，来调整咖啡/水的配比。注意请勿超过咖啡粉的 MAX（最大）刻度线。

咖啡从冲泡器中溢出。

- 放入更少的咖啡粉。
- 使用 ☕（加浓）设置冲泡美味、脱因、精制高级品牌的咖啡粉。
- 当使用全豆咖啡时，采用标准自动滴流咖啡研磨将取得最好的效果。由于非常细的咖啡粉会导致咖啡机溢出咖啡，注意请勿过度研磨。

咖啡从马克杯或旅行马克杯中溢出。

- 为防止出现咖啡从马克杯/旅行马克杯中溢出，确保使用与加注水箱水“相同”容量的杯子。

**Model/型号:**  
**49981-CN**

**Type/类别:**  
**A84**

**Rating/规格**  
**220V~ 50Hz 1300W**

**Dist.: Hamilton Beach Brands, Inc., Glen Allen, VA 23060**  
**© 2012 Hamilton Beach Brands, Inc.**

以上内容如有改动，恕不预先通知